



The Company

We are an established world force in the design and manufacture of instrumentation for industrial process control, flow measurement, gas and liquid analysis and environmental applications.

As a part of ABB, a world leader in process automation technology, we offer customers application expertise, service and support worldwide.

We are committed to teamwork, high quality manufacturing, advanced technology and unrivalled service and support.

The quality, accuracy and performance of the Company's products result from over 100 years experience, combined with a continuous program of innovative design and development to incorporate the latest technology.

ABB MEASUREMENT & ANALYTICS | USER GUIDE

ControlMaster CM30, CM50 and CMF310

Universal process controllers –
1/4, 1/2 DIN and fieldmount



Measurement made easy



Basic Level

Refer to Section 6, page 28

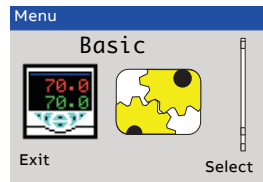

- Loop 1 (2) Setpoints
 - Local Setpoint 1 (4)
 - RSP Ratio
 - RSP Bias
 - Ramp Mode
 - Ramp Rate
- Loop 1 (2) Control
 - On/Off Hysteresis
 - Mode
 - Autotune
 - PID
 - FeedForward
- Loop 1 (2) Mot Valve
 - Ratio
 - Bias
 - Deadband
 - Travel Time
- Loop 1 (2) Time Prop
 - Cycle Time 1 (2)
- Alarm_1 (8)
 - Trip

***Advanced Level...**

Refer to Section 7.1, page 34

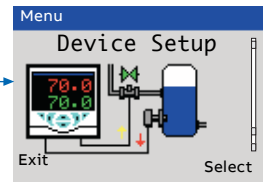

- Initial Setup
 - App. Template
 - Loop 1 (2) Output Type
 - Loop 1 (2) Split O/P
 - Instrument Tag
 - Loop 1 (2) Tag
 - Mains Freq.
 - Config Action
 - Custom Template
 - Analog 1 (2) Eng. Units
 - Tot. 1 (2) Eng. Units
- Security Setup
 - Basic Password
 - Advanced Password
 - Reset Passwords
- Custom Config
 - Loop 1 (2) PV
 - Loop 1 (2) Split O/P
 - Loop 1 (2) Valve O/P
 - Loop 1 (2) Valve FB
 - Loop 1 (2) TP OP1 (2)
 - Loop 1 (2) RSP
- IrDA Configuration
 - Setup
 - Config. Description

Refer to Section 7.2, page 37

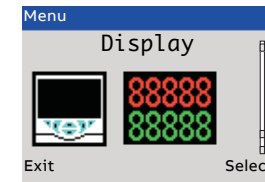

- Language
- Operator Templates
 - Page 1 (4) Template
- Operator Functions
 - Autoscroll
 - Soft Key Function
 - Auto Manual Enable
 - Local Remote Enable
 - Alarm Ack. Enable
 - Totalizer Stop/Go
 - Totalizer Reset
 - SP Adjust Enable
 - Profiler
- ▲ Chart View
 - Channel 1 (2)
 - Sample Rate
- Settings
 - Brightness
 - Contrast**
- Date & Time
 - Date Format
 - Time & Date
 - Daylight Saving
 - DS Start Time
 - DS Start Occur
 - DS End Occur
 - DS Start Day
 - DS End Day
 - DS Start Month
 - DS End Month
- Customise Pages
 - Page Number
 - Template Type
 - Titlebar Tag
 - Parameters
 - Bargraphs
 - Icons
 - Page Colors

Refer to Section 7.3, page 42

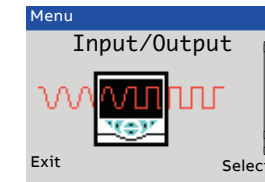

- Analog Inputs
 - Anlg Input 1 (4)
- Analog Outputs
 - Analog Output 1 (4)
- Digital I/O
 - Digital IO 1 (6)
- Relays
 - Relay 1 (4/6)

Refer to Section 7.4, page 46

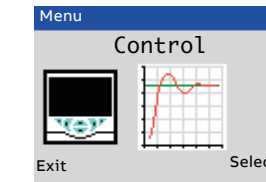

- Loop 1 (2) Setpoints
 - Low Limit
 - High Limit
 - No. of Local SP's
 - Local Setpoint 1
- Loop 1 (2) Output
 - Limits
 - Failure Actions
 - A/M Select Sources
 - Slew Rate
 - Tracking
- Track Mode
- RSP Ratio
- RSP Bias
- RSP Fault Action
- Default Setpoint
- Ramp Mode
- Ramp Rate
- Select Sources
- Loop 1 (2) Split O/P
 - Min Input 1 (2)
 - Min OP 1 (2)
 - Max Input 1 (2)
 - Max OP 1 (2)
- Loop 1 (2) Valve
 - Ratio
 - Bias
 - Deadband
 - Travel time
- Loop 1 (2) Control
 - Control Type
 - Control Action
 - On/Off Hysteresis
 - Autotune
 - PID
 - ▲ Gain Scheduling
 - ▲ FeedForward
 - Adaptive Control
 - Misc.
- Loop 1 (2) Time Prop
 - Cycle Time 1 (2)
- Output Switching
 - Switch Enable
 - Switch Source

Refer to Section 7.5, page 58

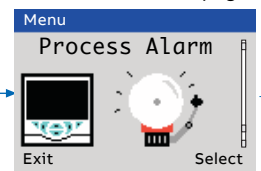

- Alarm 1 (8)
 - Type
 - Tag
 - Source
 - Trip
 - Hysteresis
 - Time Hysteresis
 - Display Enable
- Acknowledge Source
- Enable Source

- Key:**
- CMF Standard and Extended / Dual functionality
 - ▲ CMF Extended / Dual functionality only

Refer to Section 7.6, page 60

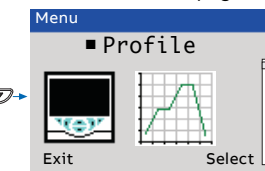

- Common Settings
 - SPT Start Condition
 - Ramp Control
 - Program Control
 - Recovery
 - Segment Options
 - PV Event Trip
 - User Value Limits
 - Fast Run Mode
- Enter Program
 - Program No
 - Name
 - Repeat Count
 - Setpoint Start/End
 - Holdback Hysteresis
 - Enter Segments
 - Guaranteed Ramp/soak
 - Event 1 to 8
 - PV Event
 - Timed Event Offset
 - Timed Event Length
 - User Value

Refer to Section 7.7, page 76

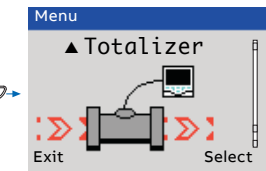

- Totalizer 1 (2)
 - Mode
 - Source
 - Count Direction
 - Units
 - Count Rate
 - Cutoff
 - Stop Go Source
 - Total DPs
 - Preset Count
 - Predet Count
 - Intermed'te Count
 - Wrap Enable
 - Reset Source
 - Reset Days
 - Reset Hour

Refer to Section 7.8, page 76

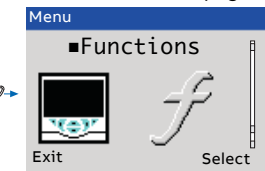

- Logic Equations
 - Equation Number
 - Operand 1
 - Invert 1
 - Operator 1
- Math Blocks
 - Math Block Number
 - Block Type
 - Eng. DPs
 - Eng. Low / Eng. High
 - Eng. Units
 - Fault Action
- Linearizer 1 (2)
 - Source
 - Delay Time
 - On Time
- Delay Timer 1 (2)
 - Source
 - Delay Time
 - On Time
- Real Time Alarms
 - Real Time Alarm 1 (2)
- Bank Control
 - Bank Size
 - Control Source
 - Bank 1 (6)

Refer to Section 7.9, page 83

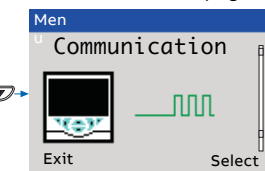

- Refer to IM/CM/C-EN for parameter details.
- Refer to Section 7.10, page 83
- Men
- u
- Diagnosics
 - 123
- Exit
- Select
- Diagnostic History
 - Source Analysis
 - Analog Source
 - Digital Source
 - Invalid Sources

Refer to Section 7.11, page 87



- Instrument Type
- I/O Build
- No. Analog Inputs
- No. Analog Outputs
- No. Relays
- No. Digital I/O
- Functionality
- Serial No.
- Hardware Revision
- Software Revision

*When in Advanced Level (configuration mode), press and hold the key to return to the standard Operator page – see Fig. 3.1, page 5.

**Enabled for CM30 and CM50 only

Contents

1	Safety	3
1.1	Electrical Safety	3
1.2	Symbols	3
1.3	Health & Safety	3
2	Introduction	4
2.1	EC Directive 89/336/EEC	4
2.2	End of Life Disposal	4
2.3	UL Class I, Division 2 (CMF310 only – when ordered)	4
2.4	UL Class I, Division 2 (CMF310 si commandé)	4
3	Display Overview	5
3.1	Front Panel Keys	6
4	Installation	7
4.1	Siting	7
4.2	Dimensions	8
4.2.1	CM30 Controller	8
4.2.2	CM50 Controller	8
4.2.3	CMF310 Controller – Panel-, Pipe- and Wall-mount Dimensions	9
4.2.4	CMF310 Weathershield – Pipe- and Wall-mount Installations	11
4.3	Mounting	12
4.3.1	CM30 and CM50 Controllers	12
4.3.2	CMF310 Controller	12
4.4	Jumper Links for Relay Outputs – CM30 and CM50 Controllers	13
4.4.1	Removing the Controller from its Case – CM30 and CM50	13
4.4.2	Resetting Jumper Links – CM30 and CM50	13
4.5	Accessing the Connection Board – CMF310 Controller	14
4.6	Electrical Connections	15
4.6.1	CM30 Electrical Connections	16
4.6.2	CM50 Electrical Connections	17
4.6.3	Analog Inputs – CM30 and CM50 Controllers	18
4.6.4	Digital Input / Output – CM30 and CM50 Controllers	19
4.6.5	CMF310 Electrical Connections	20
4.6.6	Analog Inputs – CMF310 Controllers	21
4.6.7	Digital Input / Output, Relays and Analog Output Connections – CMF310 Controllers	22
4.6.8	Frequency / Pulse Input (All Controllers)	22
5	Operator Level Menus	23
5.1	Diagnostic Status Bar	23
5.2	Diagnostic View	24
5.3	Security Options	24
5.4	Access Level	24
5.5	Profile Operator page	25
5.5.1	Profile Operator page menu functions	25
5.6	Operator page overviews	26
6	Basic Level	28

7	Advanced Level	34
7.1	Device Setup	34
7.2	Display	37
7.3	Input/Output	42
7.4	Control	46
7.5	Process Alarm	58
7.6	Profile	60
7.6.1	Ramp Types	61
7.6.2	Guaranteed Ramp / Soak	62
7.6.3	Set Point Start Condition – Current PV	63
7.6.4	Retort Function	64
7.6.5	Segment Events	65
7.6.6	Profile Parameters	66
7.7	Totalizer	72
7.7.1	Calculating the Totalizer Count Rate Manually	74
7.8	Functions	76
7.9	Communication	83
7.10	Diagnostics	83
7.10.1	Diagnostic Messages	84
7.11	Device Info	87
8	Templates and Functionality	88
8.1	Basic Templates	88
8.1.1	Single Loop / Single Loop with Remote Setpoint	88
8.2	Standard Templates	89
8.2.1	Auto / Manual Station (Low Signal Selection / Digital Signal Selection)	89
8.2.2	Analog Backup Station (Low Signal Selection / Digital Signal Selection)	90
8.2.3	Single Indicator	91
8.2.4	Dual Indicator	91
8.3	Extended Templates	92
8.3.1	Feedforward / Feedforward with Remote Setpoints	92
8.3.2	Cascade / Cascade with Remote Setpoints	92
8.3.3	Cascade with Feedforward	93
8.3.4	Ratio Controller (Internal / External Ratio)	94
8.3.5	Ratio Station (Internal / External Ratio)	94
8.4	Dual Loop Templates	95
8.4.1	Dual Loop – Local Setpoint / Local Setpoint	95
8.4.2	Dual Loop – Remote Setpoint / Local Setpoint	96
8.4.3	Dual Loop – Remote Setpoint / Remote Setpoint	96
9	PC Configuration	97
10	Specification	98
Appendix A	– Digital and Analog Sources	104
A.1	Digital Sources	104
A.2	Analog Sources	105
Appendix B	– Error Codes	106
B.1	Configuration Error Codes	106
B.2	Profile Error Codes	107
Appendix C	– Analog Input Engineering Units	108
C.1	Standard Units	108
Appendix D	– Output Type Assignments	109
Notes		110

1 Safety

Information in this manual is intended only to assist our customers in the efficient operation of our equipment. Use of this manual for any other purpose is specifically prohibited and its contents are not to be reproduced in full or part without prior approval of the Technical Publications Department.





1.1 Electrical Safety





This equipment complies with the requirements of CEI/IEC 61010-1:2010 3rd edition 'Safety Requirements for Electrical Equipment for Measurement, Control and Laboratory Use' and complies with US NEC 500, NIST and OSHA.

If the equipment is used in a manner NOT specified by the Company, the protection provided by the equipment may be impaired.

1.2 Symbols

One or more of the following symbols may appear on the equipment labelling:

	Warning – Refer to the manual for instructions
	Caution – Risk of electric shock
	Functional earth (ground) terminal
	Protective earth (ground) terminal

	Direct current supply only
	Alternating current supply only
	Both direct and alternating current supply
	The equipment is protected through double insulation

1.3 Health & Safety

Health and Safety

To ensure that our products are safe and without risk to health, the following points must be noted:

- The relevant sections of these instructions must be read carefully before proceeding.
- Warning labels on containers and packages must be observed.
- Installation, operation, maintenance and servicing must be carried out only by suitably trained personnel and in accordance with the information given.
- Normal safety precautions must be taken to avoid the possibility of an accident occurring when operating in conditions of high pressure and / or temperature.

Safety advice concerning the use of the equipment described in this manual or any relevant hazard data sheets (where applicable) may be obtained from the Company, together with servicing and spares information.

2 Introduction

This manual provides details for the ControlMaster CM30 (1/4 DIN), CM50 (1/2 DIN) controllers with Extended / Dual Loop functionality and all variants of the CMF310 fieldmount controller.

CMF controller functionality in this manual is identified using the following symbols:

- Standard and Extended / Dual functionality
- ▲ Extended / Dual functionality only

Note.

- Read all relevant sections of this guide before configuring the system or modifying system parameters.
- Install and use associated equipment in accordance with the relevant national and local standards.
- System configuration must be carried out only by users or personnel with approved access rights (user privileges).

2.1 EC Directive 89/336/EEC

In order to meet the requirements of the EC Directive 89/336/EEC for EMC regulations, this product must be used in an industrial environment.

2.2 End of Life Disposal

Controllers with Standard functionality and above contain a small lithium battery that must be removed and disposed of responsibly in accordance with local environmental regulations.

2.3 UL Class I, Division 2 (CMF310 only – when ordered)

This equipment is suitable for use in Class I, Division 2, groups A, B, C, and D hazardous locations or non-hazardous locations only.

WARNING! Do not open equipment in an explosive atmosphere.

This equipment must be installed in accordance with the pertinent clauses of the National Electrical Code and/or Canadian Electrical Code for hazardous locations.

The terminal cover retaining screw must be tightened to a torque of 50 cN.m.

WARNING! Explosion hazard! Substitution of components may impair suitability for class I, division 2

2.4 UL Class I, Division 2 (CMF310 si commandé)

Cet équipement est adapté uniquement à une utilisation en zones dangereuses de classe I, division 2, groupes A, B, C et D ou non dangereuses.

ATTENTION ! Ne pas ouvrir l'équipement dans une atmosphère explosive.

Cet équipement doit être installé conformément aux clauses du Code électrique national pour les Etats-Unis ou au Code électrique canadien pour le Canada relatives aux zones dangereuses.

La vis de fixation du couvercle de protection de borne doit être serrée à un couple de 50 cN.m.

ATTENTION ! Risque d'explosion ! Le remplacement de certains composants peut compromettre la conformité à la classe I, division 2.

3 Display Overview

The ControlMaster displays and icons are shown in Fig. 3.1:

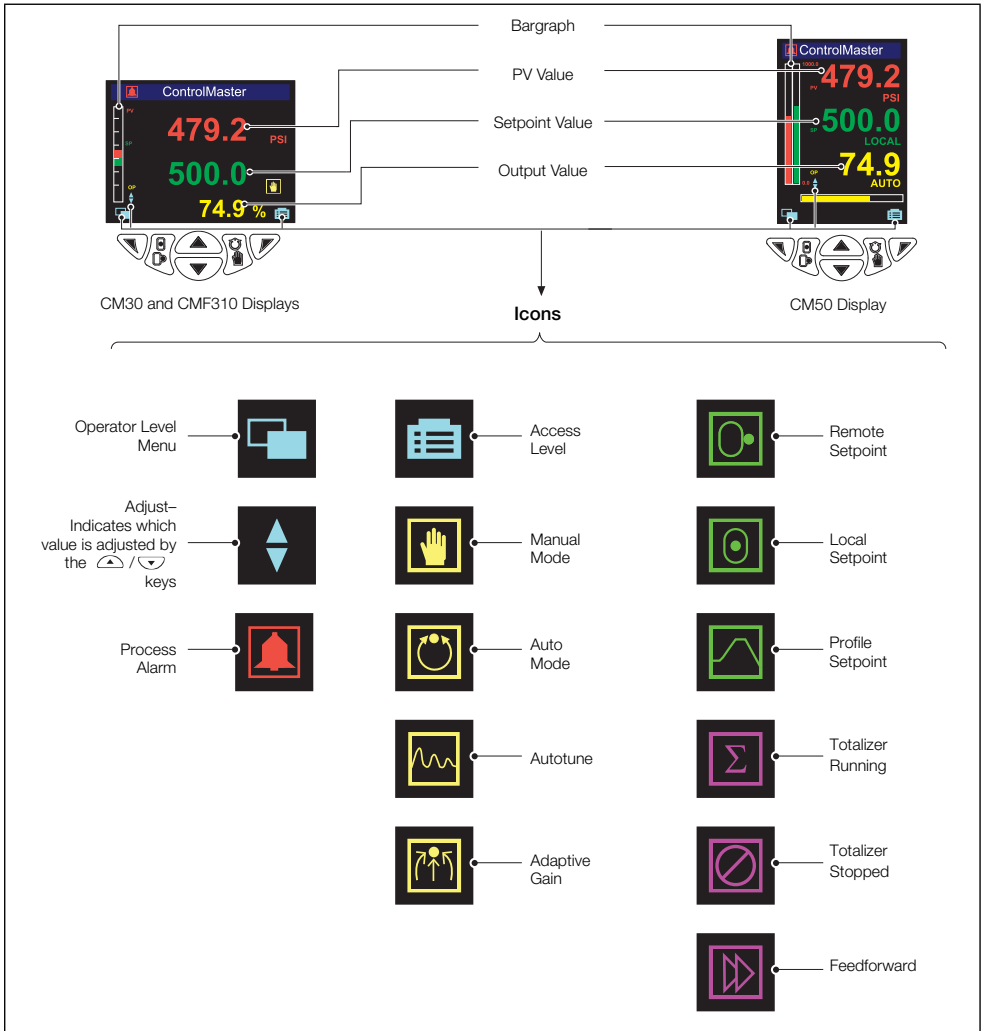

Fig. 3.1 ControlMaster Displays and Icons

3.1 Front Panel Keys

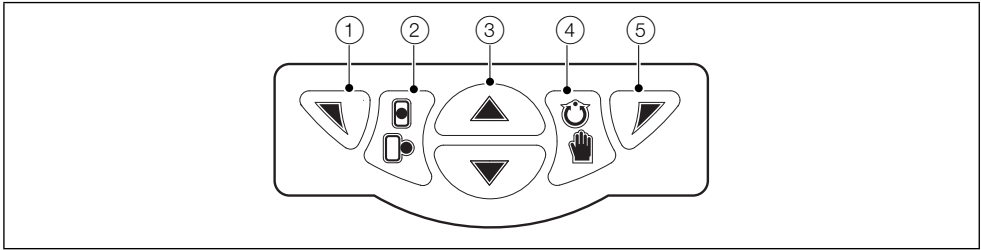

Fig. 3.2 Front Panel Keys

- ① Navigation (left) / *Operator Level* access key – see page 23.
- ② Local / Remote setpoint mode selection key.
- ③ Up / Down keys – navigate up / down menus and increase / decrease displayed values.
- ④ Auto / Manual control mode selection key.
- ⑤ Navigation key (right) / programmable Soft Key – see page 38.

Note. When a Soft Key option is assigned to key ⑤, the *Advanced Level* (see page 34) must be accessed using the *Operator Level* access key ①.

4 Installation

Caution. Select a location away from strong electrical and magnetic fields. If these cannot be avoided, particularly in applications where 'walkie talkies' are used, connect using screened cables within grounded metal conduit

4.1 Siting

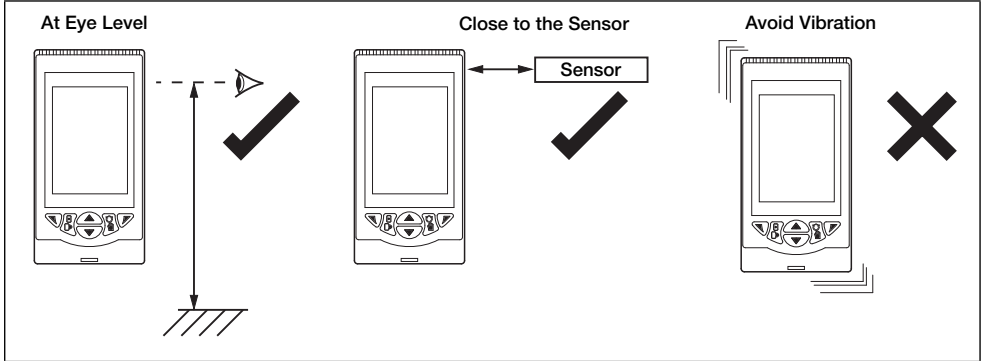

Fig. 4.1 Siting (Applicable to CM30, CM50 and CMF310 – CM50 Shown for Example Only)

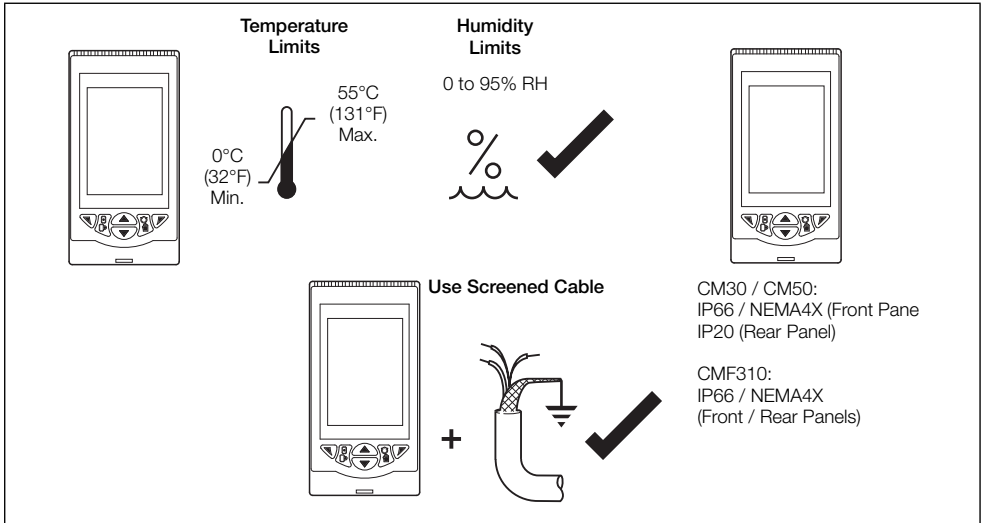

Fig. 4.2 Environmental Requirements (Applicable to CM30, CM50 and CMF310 – CM50 Shown for Example Only)

4.2 Dimensions

4.2.1 CM30 Controller

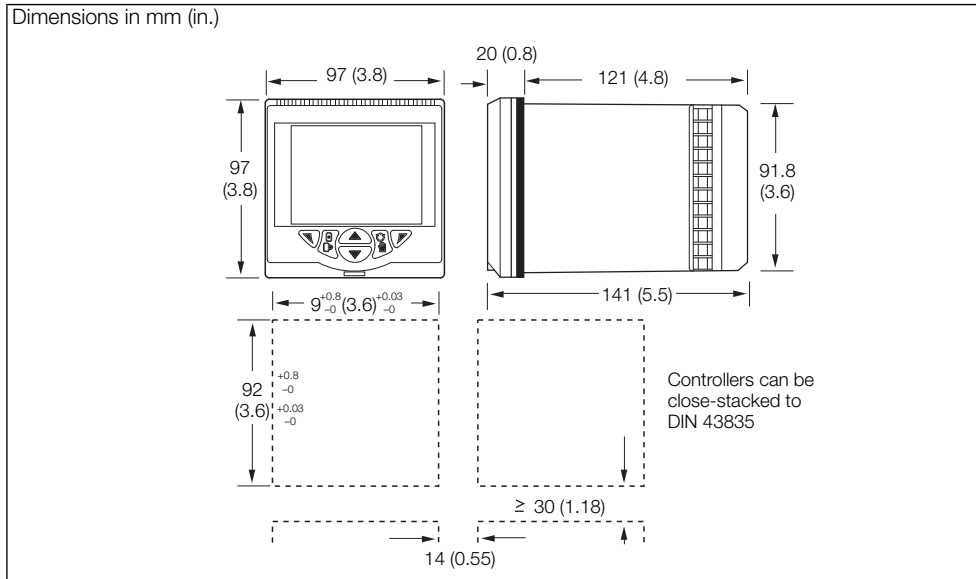

Fig. 4.3 ControlMaster CM30 Dimensions

4.2.2 CM50 Controller

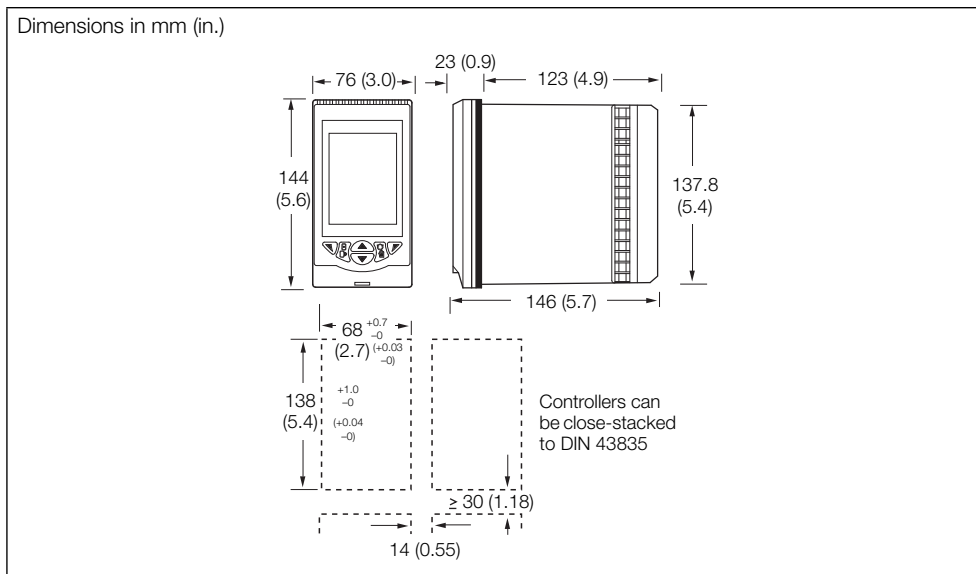

Fig. 4.4 ControlMaster CM50 Dimensions

4.2.3 CMF310 Controller – Panel-, Pipe- and Wall-mount Dimensions

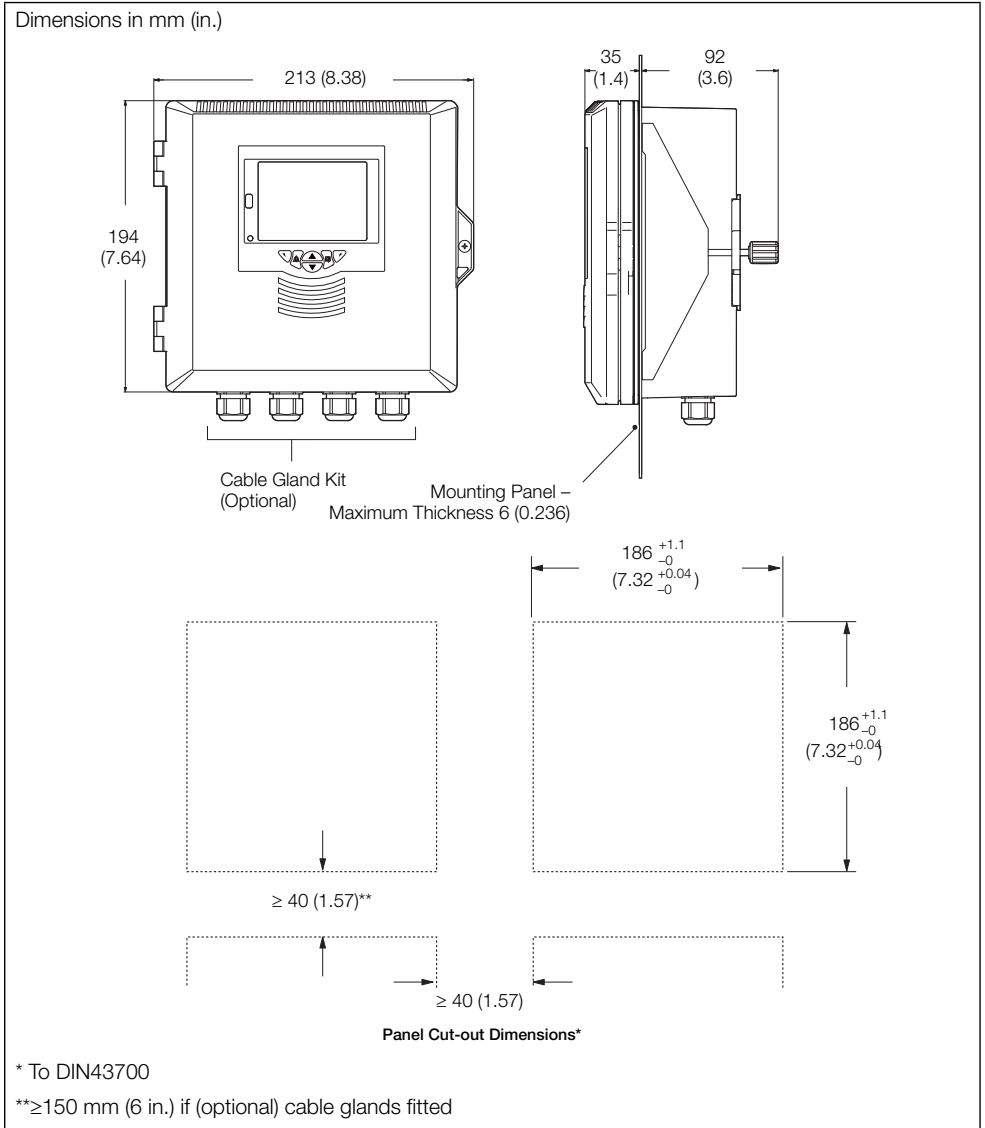

Fig. 4.5 ControlMaster CMF310 Panel-mount Option

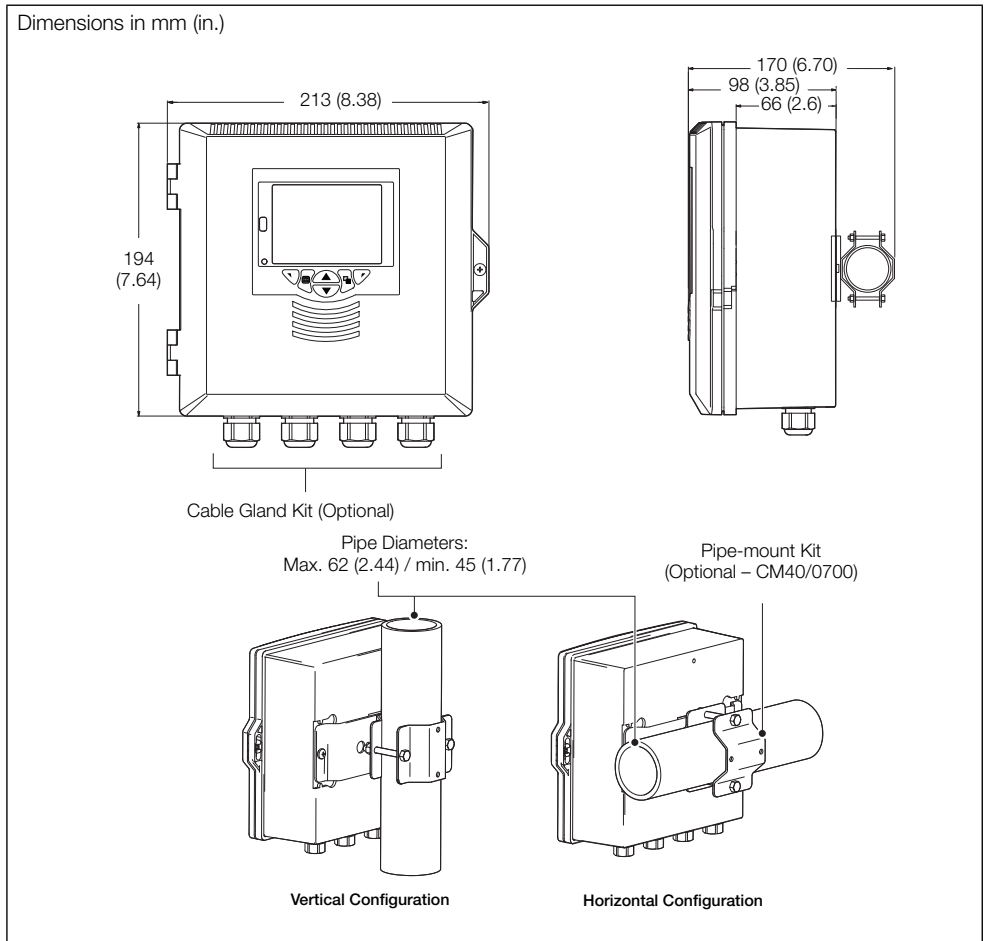

Fig. 4.6 ControlMaster CMF310 Pipe-mount Option

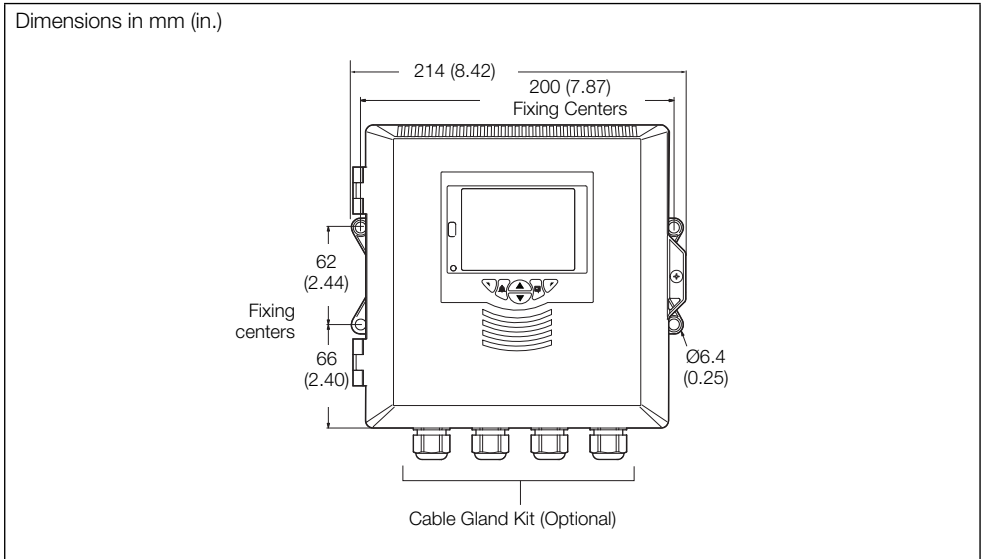

Fig. 4.7 ControlMaster CMF310 Wall-mount Option

4.2.4 CMF310 Weathershield – Pipe- and Wall-mount Installations

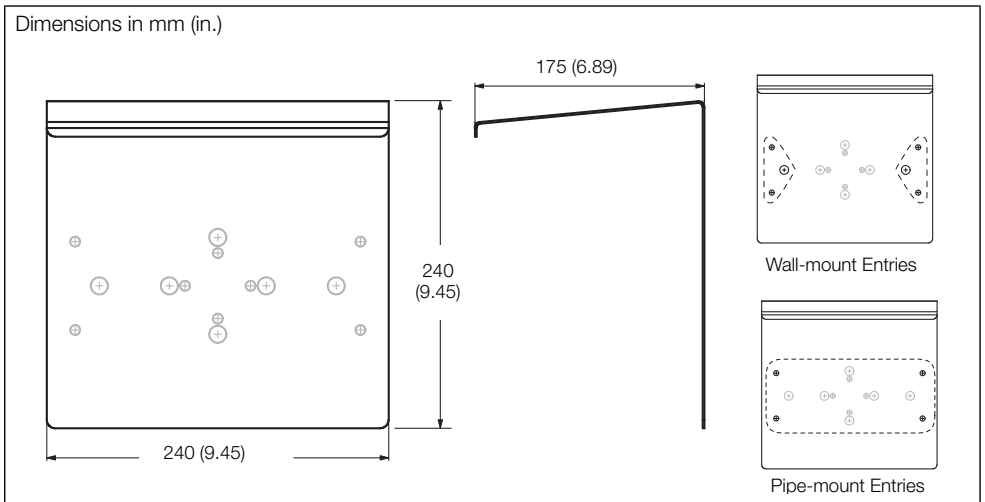

Fig. 4.8 ControlMaster CMF310 Weathershield (CM40/0702) – Pipe- and Wall-mount (CM40/0700) Options

4.3 Mounting

4.3.1 CM30 and CM50 Controllers

ControlMaster CM30 and CM50 controllers are designed for panel mounting. For NEMA4X protection, a panel thickness of 2.5 mm (0.1 in.) is required.

To panel-mount the CM30 / CM50 controller:

1. Cut a hole of the correct size for the controller in the panel (see page 8 for dimensions).
2. Insert the controller into the panel cut-out.

Referring to Fig. 4.9:

3. Position the upper panel clamp (A) at the top front of the case against the panel.
4. Locate the panel clamp anchor (B) in slot (C).
5. Tighten the panel clamp anchor screw (D) until panel clamp (A) is secured against the panel (torque 0.1 Nm [0.9 lbf/in.]).

Note. Do not overtighten the screw.

6. Repeat steps 3 to 5 to fit the lower panel clamp (E) and panel clamp anchor (F).

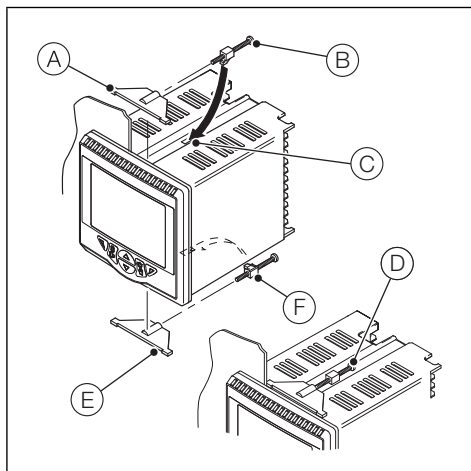

Fig. 4.9 Mounting Details – CM30 / CM50 Controllers

4.3.2 CMF310 Controller

ControlMaster CMF310 controllers can be panel-, pipe- or wall-mounted. For NEMA4X protection, a panel thickness of 6 mm (0.236 in.) is required. (For pipe-mount details, see Fig. 4.6, page 10. For wall-mount details, see Fig. 4.7, page 11.)

To panel-mount the CMF310 controller:

1. Cut a hole of the correct size for the controller in the panel (see page 9 for cut-out dimensions).

Referring to Fig. 4.10:

Note. It may be necessary to cut a notch out of the panel at position (A) to accommodate the small rod on the lower face of the controller (B).

2. Insert the controller (B) into the panel cut-out (C).
3. Position the panel clamps (D) at each side of the case against the panel.
4. Tighten each panel clamp anchor screw (E) until both panel clamps (D) are secured against the panel (torque 0.5 to 0.6 Nm [4.42 to 5.31 lbf/in.]).

Note. Do not overtighten the screws.

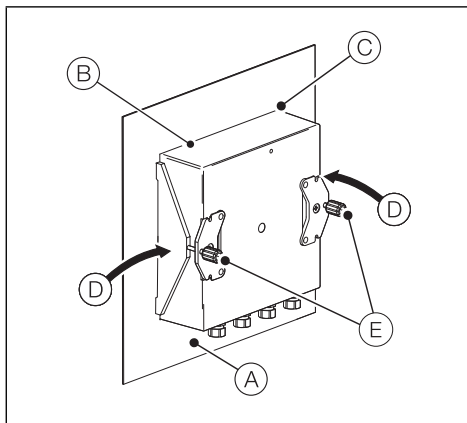

Fig. 4.10 Mounting Details – CMF310 Controllers

4.4 Jumper Links for Relay Outputs – CM30 and CM50 Controllers

The factory-set default for relay action is N/O.

4.4.1 Removing the Controller from its Case – CM30 and CM50

The ControlMaster inner assembly must be removed from its case to access the relay contact jumper links.

Referring to Fig. 4.11:

1. Insert the bezel release tool (A) into the front panel slot (B) below the function keys.
2. Press the bezel release tool (A) fully in and then down (C) until the shoulder on the tool engages with the notch behind the controller front plate.
3. Pull the bezel release tool (A) to withdraw the inner assembly from the case (D).

Note. If the bezel release tool is mislaid, 2 small flat-headed screwdrivers (4 mm [0.15 in.]) can be used as alternative tools, one inserted into the front panel slot and the second for leverage in the notch on the underside of the controller front plate. The notch is the only area that can be used as a leverage point – do not attempt to lever the front panel from any other area.

4.4.2 Resetting Jumper Links – CM30 and CM50

Note. The factory-set default for all jumper links is N/O.

1. The links associated with the relay outputs are shown in Fig. 4.12.
2. If necessary, move the link to select the relay action required (N/O or N/C).

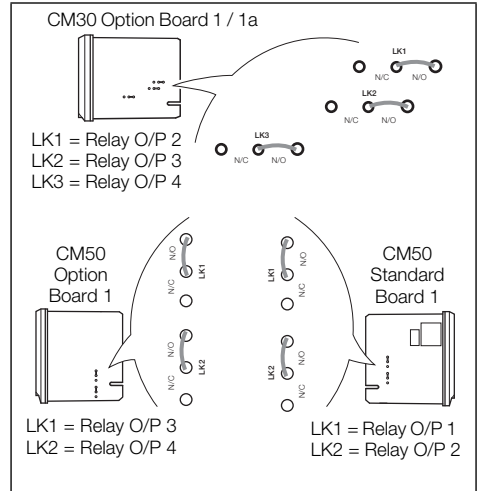

Fig. 4.12 Jumper Links for Relay Outputs

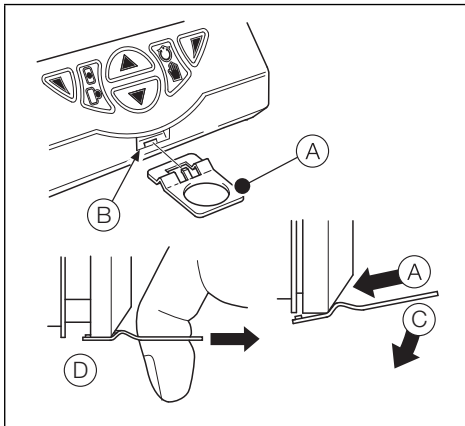

Fig. 4.11 Removing the Controller from its Case

4.5 Accessing the Connection Board – CMF310 Controller

Note. Before fitting cable glands, identify the connections required and cable gland entries to be used.

Referring to Fig. 4.13:

1. Using a pozi-drive screwdriver, turn the terminal cover retaining screw (A) counter-clockwise (1/4 turn) and open the cover.
2. Turn the connection board cover plate retaining screw (B) anti-clockwise until the cover plate (C) can be removed.
3. Make connections to connection board terminals – see Fig. 4.19, page 20.
4. Refit cover plate (C) and secure it by turning retaining screw (B) clockwise until finger-tight. Close the door and turn door retaining screw (A) 1/4 turn clockwise to secure.

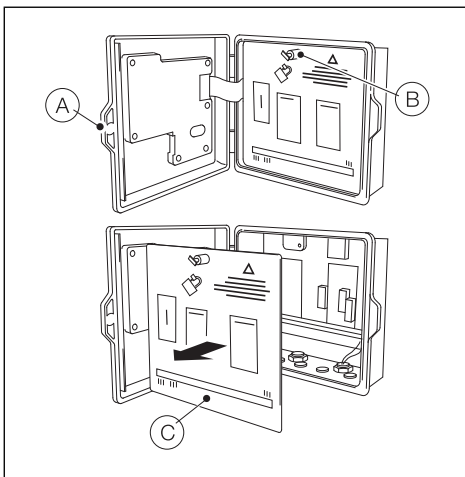

Fig. 4.13 Accessing the CMF310 Controller Connection Board

4.6 Electrical Connections

Warning.

- The controller is not fitted with a switch therefore a disconnecting device such as a switch or circuit breaker conforming to local safety standards must be fitted to the final installation.
- The switch must be mounted in close proximity to the controller within easy reach of the operator and must be marked clearly as the disconnection device for the controller.
- Remove all power from supply, relay and any powered control circuits and high common mode voltages before accessing or making any connections.
- Use cable appropriate for the load currents. The CM30 and CM50 terminals accept cables from 18 to 14 AWG (0.8 to 2.5mm²). The CMF160 terminals accept cables from 26 to 14 AWG (0.14 to 2.5mm²)
- Always route signal leads and power cables separately, preferably in earthed (grounded) metal conduit.
- It is strongly recommended that screened cable is used for signal inputs and relay connections. For I/P lead lengths > 30 m (98 ft.) screened cables must be used.
- Instruments conform to Mains Power Input Overvoltage Category 2, Pollution Degree 2 (EN601010-1). (The CM30 and CM50 are protected through double insulation – Insulation Class II.) CMF310 Insulation Class 1.
- Analog / digital inputs and outputs, transmitter power supply and DC power supply are SELV (Safety Extra Low Voltage) circuits.
- All connections to secondary circuits must have basic insulation.
- After installation, there must be no access to live parts, for example terminals.
- Terminals for external circuits are for use with equipment with no accessible live parts only.
- If the controller is used in a manner not specified by the Company, the protection provided by the equipment may be impaired.
- All equipment connected to the controller's terminals must comply with local safety standards (IEC 60950, EN601010-1).

CM30, CM50, CMF310 Controllers – USA and Canada Only

- The supplied cable glands are provided for the connection of signal input and ethernet communication wiring ONLY.
- The supplied cable glands and use of cable / flexible cord for connection of the mains power source to the mains input and relay contact output terminals is not permitted in the USA or Canada.
- For connection to mains (the mains input and relay contact outputs), use only suitably rated field wiring insulated copper conductors rated min. 300 V, 14 AWG, 90C. Route wires through suitably rated flexible conduits and fittings.

Warning.

Note. The CM30 and CM50 terminal screws must be tightened to a torque of 0.1 Nm (0.9 lbf/in.). The CMF310 terminal screws must be tightened to a torque of 0.5 to 0.6 Nm (4.42 to 5.31 lbf/in.).

4.6.1 CM30 Electrical Connections

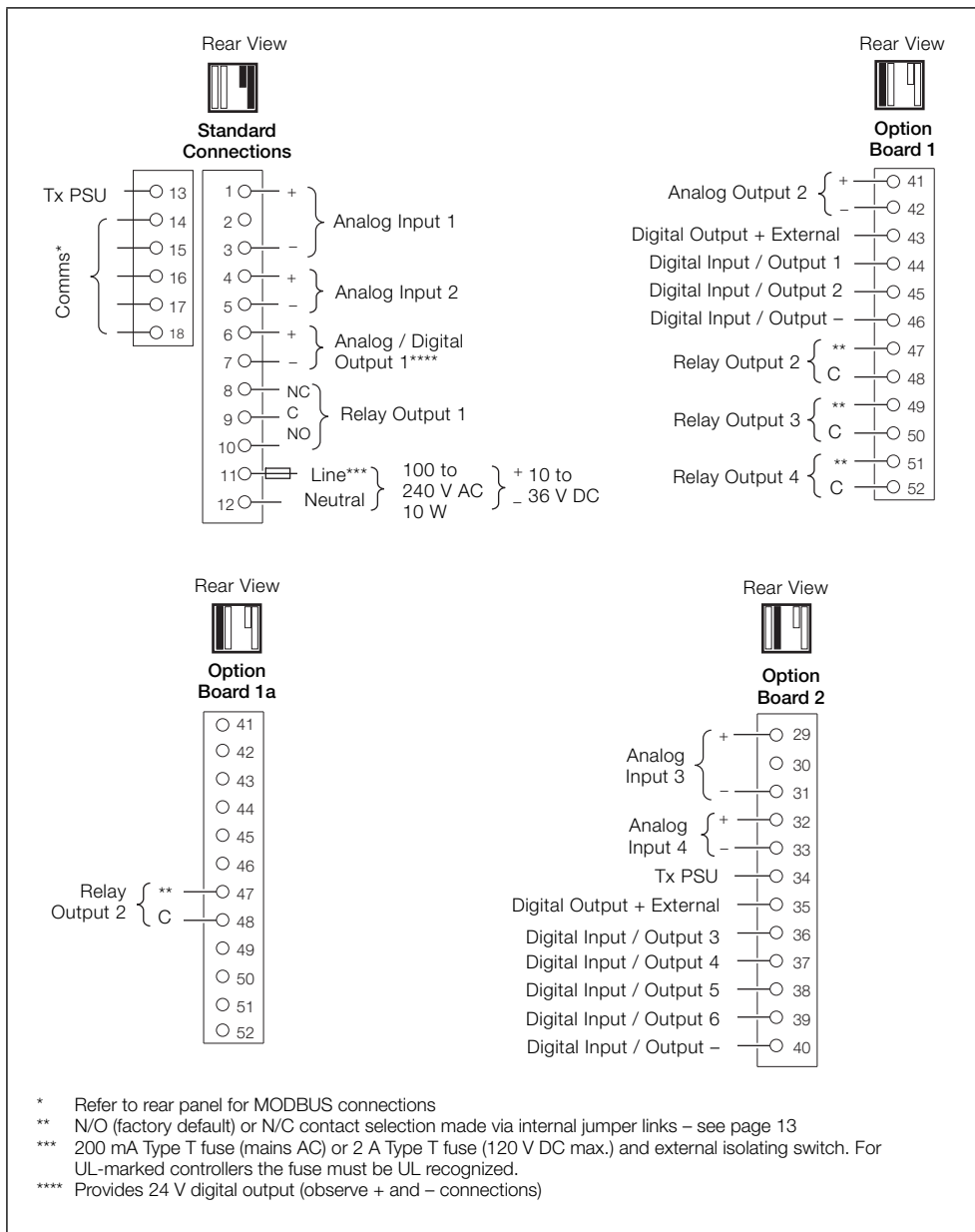

Fig. 4.14 CM30 Electrical Connections

4.6.2 CM50 Electrical Connections

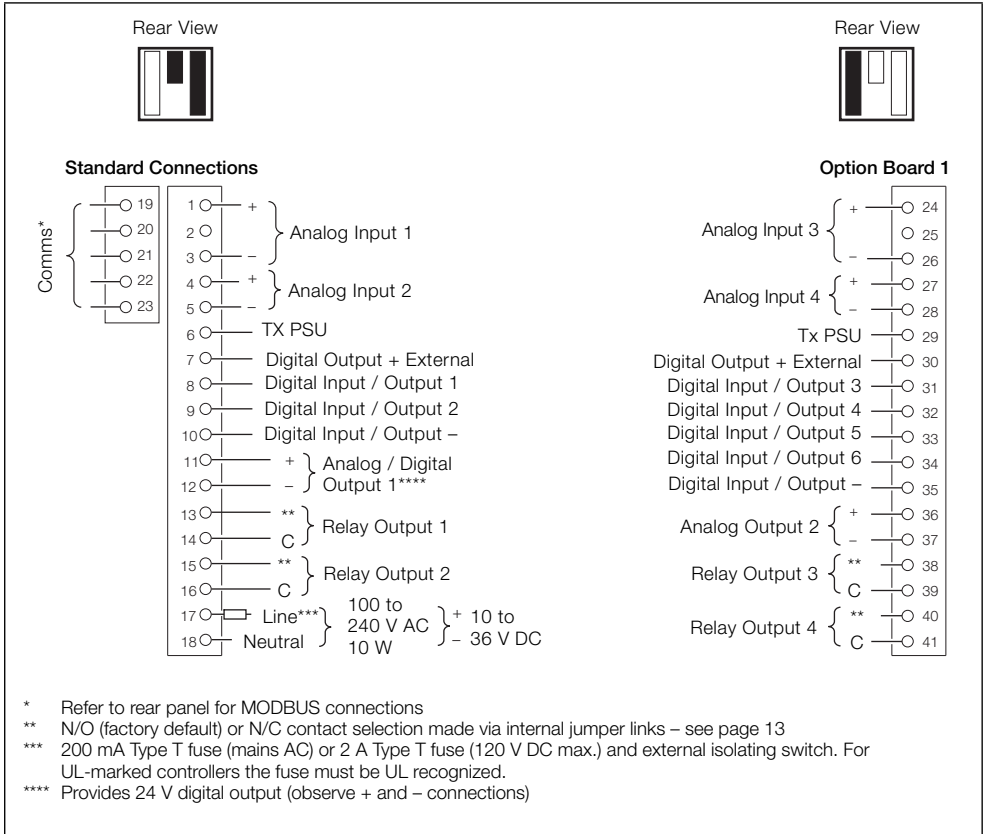

Fig. 4.15 CM50 Electrical Connections

4.6.3 Analog Inputs – CM30 and CM50 Controllers

Note. Standard terminal connections for inputs 1 and 2 are shown in Fig. 4.16. Optional analog inputs 3 and 4 are shown in Fig. 4.17.

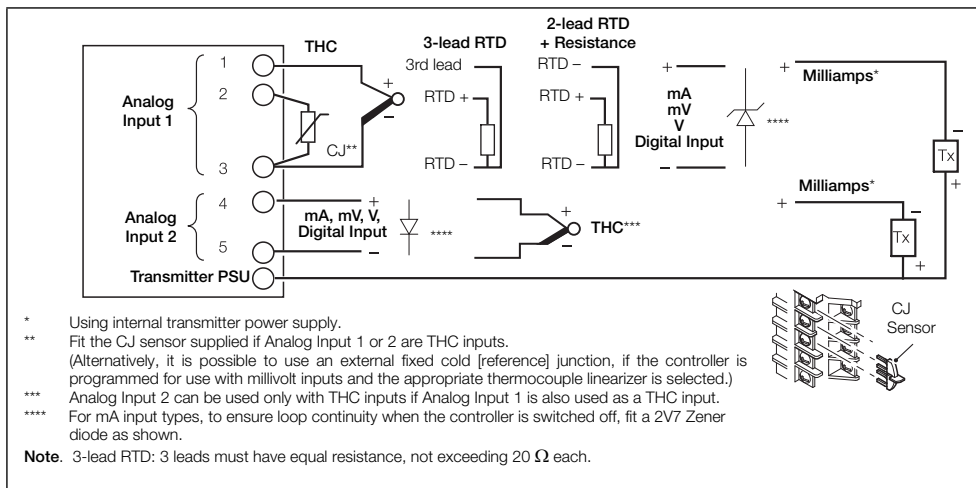

Fig. 4.16 Standard Analog Inputs (1 and 2) – CM30 and CM50 Controllers

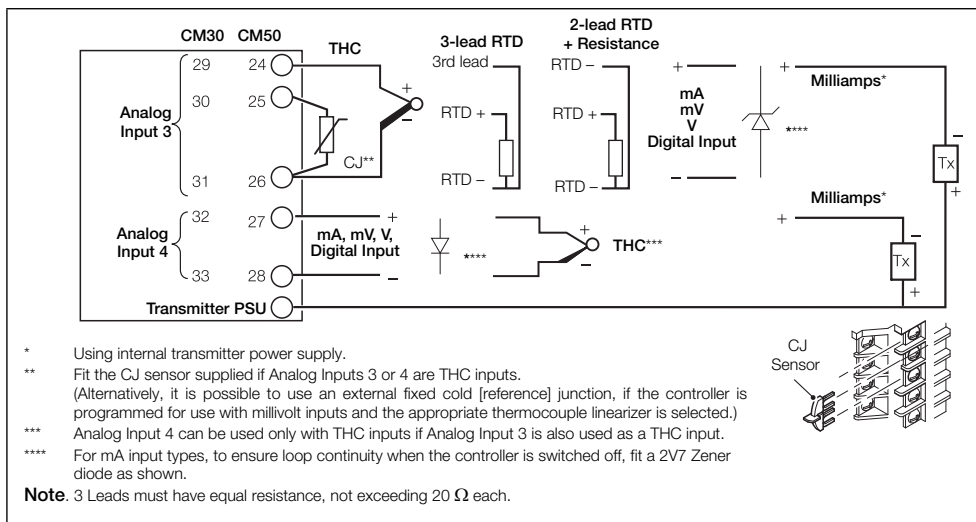

Fig. 4.17 Optional Analog Inputs (3 and 4) – CM30 and CM50 Controllers

4.6.4 Digital Input / Output – CM30 and CM50 Controllers

Note. Digital input and open collector digital output connections for CM30 and CM50 controllers are shown in Fig. 4.18 – see page 102 for Digital Input / Output type options.

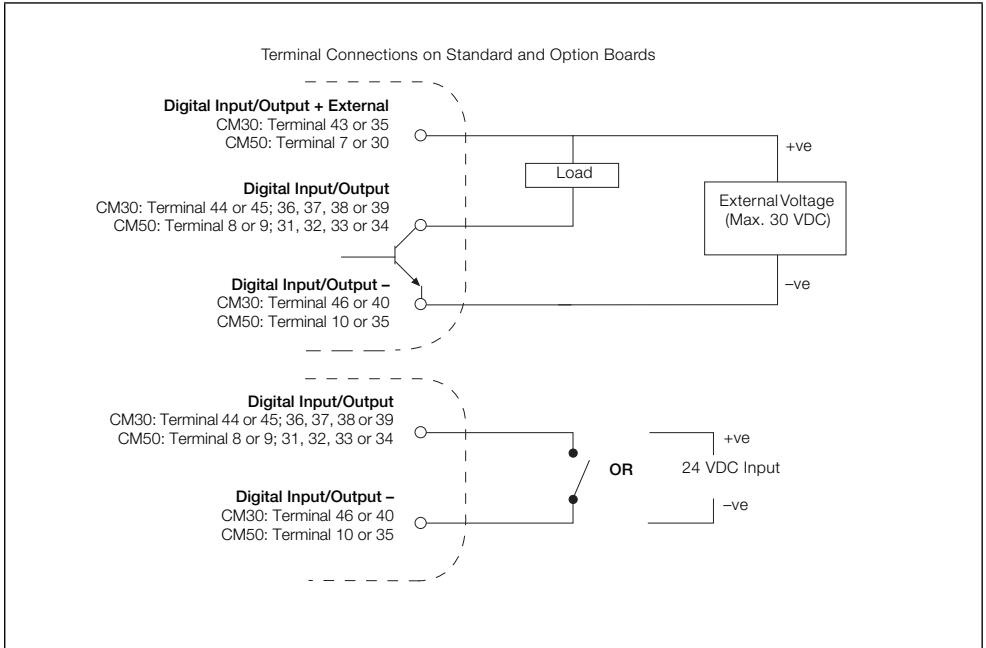

Fig. 4.18 Digital Input and Open Collector Digital Output Connections – CM30 and CM50 Controllers

4.6.5 CMF310 Electrical Connections

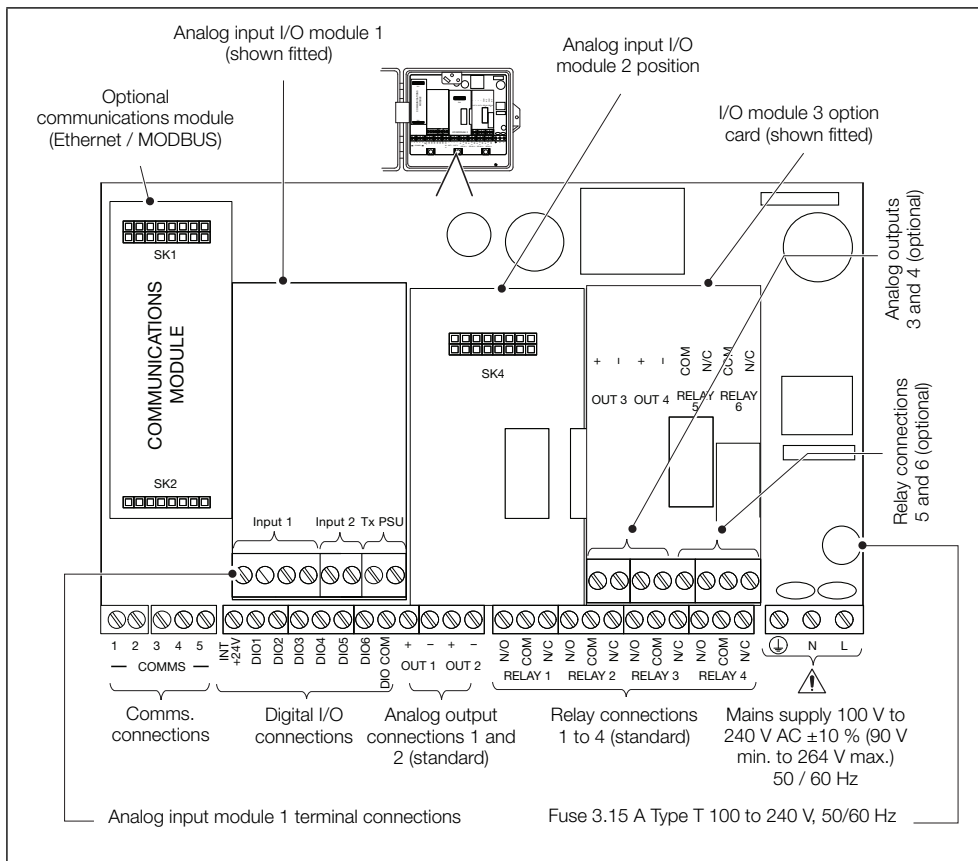

Fig. 4.19 CMF310 Electrical Connections

4.6.6 Analog Inputs – CMF310 Controllers

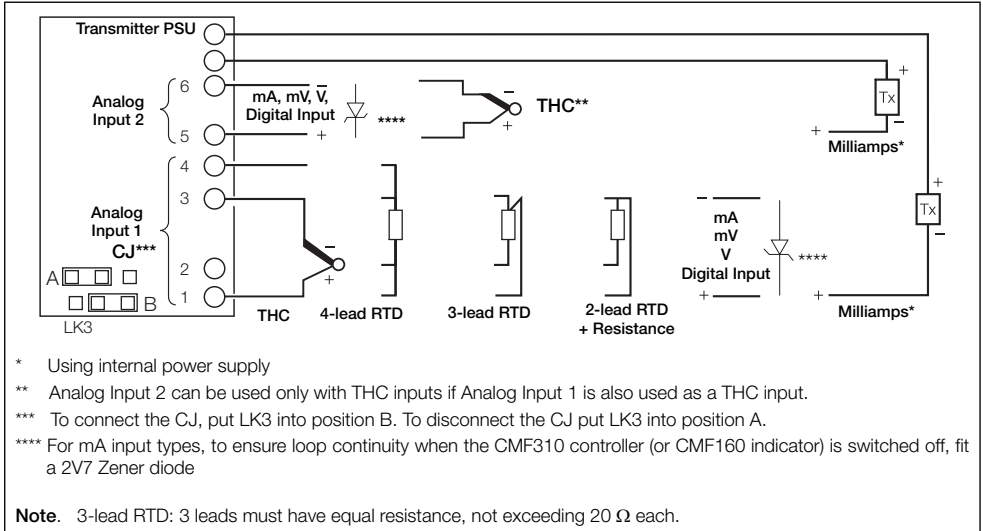

Fig. 4.20 Analog Inputs (1 and 2) – CMF310 Controllers

4.6.7 Digital Input / Output, Relays and Analog Output Connections – CMF310 Controllers

Note. Digital input / output, relays and analog output connections for CMF310 controllers are shown in Fig. 4.21 – see page 102 for Digital Input / Output type options.

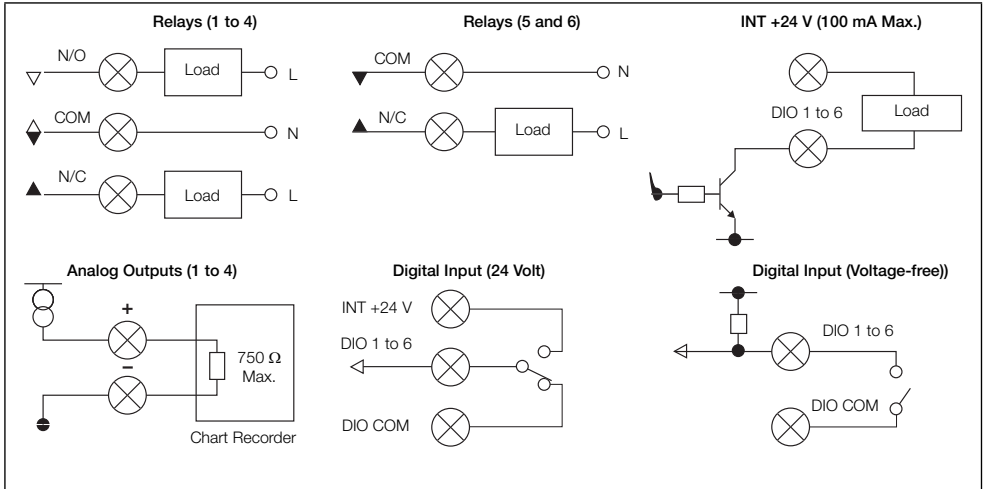

Fig. 4.21 Digital Input / Output, Relays and Analog Output Connections – CMF310 Controllers

4.6.8 Frequency / Pulse Input (All Controllers)

Note. This input is designed primarily for use with flowmeters.

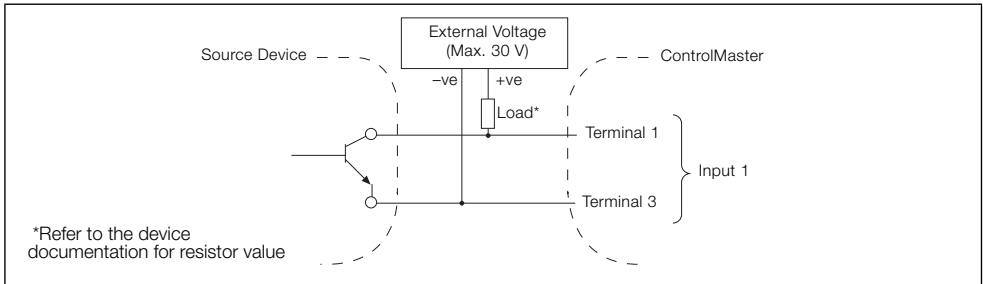
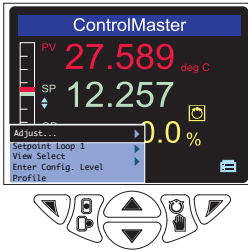

Fig. 4.22 Frequency / Pulse Input (All Controllers)

5 Operator Level Menus



Operator level menus are used to adjust setpoint(s) and output(s), select setpoints, select the view and to enter *Basic* and *Advanced* modes (via the Access level).

To access Operator Level menus:

1. From the *Operator Page*, press to view the available menus.
2. Use the / keys to scroll through the menus and menu options.
3. Press to expand menu levels and to select menu options or press to return to the previous menu.

Menu functions are described in Table 5.1.

Autotune	Used to start or stop an autotune routine. This menu is enabled only if <i>Autotune</i> mode is <i>On</i> .
Adjust	Enables a value to be adjusted using the / keys. The icon next to a value indicates the current adjustable selection.
Setpoint Select	Selects the local setpoint to be used (displayed only if more than 1 local setpoint is configured).
Alarm Acknowledge	Acknowledges any active but unacknowledged alarms.
View Select	Selects the <i>Operator</i> view to be displayed.
Enter Config. Level	Displays the <i>Access Level</i> selection views – see Section 5.4, page 24 for security options.
Profile	Displays the <i>Profile Level</i> selection views – see Section 7.6, page 60 for <i>Profile</i> options.

Table 5.1 Operator Level Menu Functions

5.1 Diagnostic Status Bar

NAMUR (NE107) Status Icon

- Failure
- Maintenance
- Out of Spec
- Check Function
- High Process Alarm
- Low Process Alarm
- High Latch Alarm
- Low Latch Alarm

Description of diagnostic or alarm tag.
 The highest priority diagnostic or alarm is displayed. Other active diagnostic / alarm states can be viewed on the *Diagnostic View* – see page 24.

Fig. 5.1 ControlMaster Diagnostic Status Bar (ControlMaster CM30 Shown)

5.2 Diagnostic View

The *Diagnostic View* can be selected from the *Operator / View Select* menu. All currently active diagnostic alarm states are displayed in the *Diagnostic View*.

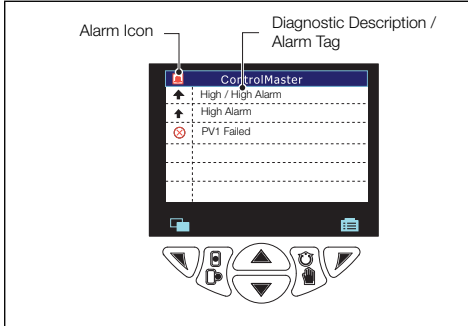

Fig. 5.2 ControlMaster Diagnostic View

5.3 Security Options

Passwords can be set to enable secure end-user access at 2 levels: *Basic* and *Advanced*. The *Service* level is password protected at the factory and reserved for factory use only.

Passwords are set, changed or restored to their default settings at the *Device Setup / Security Setup* parameter – see page 35.

Note. When the controller is powered-up for the first time the *Basic* and *Advanced* level levels can be accessed without password protection. Protected access to these levels must be allocated on-site as required.

5.4 Access Level

Level	Access
Logout	Displayed after <i>Basic</i> or <i>Advanced</i> level are accessed. Logs the user out of <i>Basic</i> or <i>Advanced</i> level. If passwords are set, a password must be entered to access these levels again after selecting <i>Logout</i> .
Read Only	Enables all parameter settings to be viewed
Basic	Enables access to the <i>Basic</i> level and adjustment of <i>PID</i> parameters (see page 30), enabling autotuning configuration and adjustment of alarm trip points.
Advanced	Enables configuration access to all parameters.
Service	Reserved for use by authorized service personnel.

Table 5.2 Access Levels

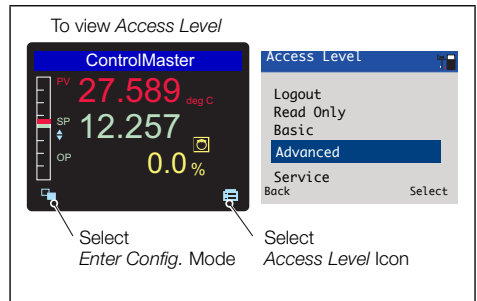

Fig. 5.3 Access Level

Note. A 5-minute time-out period enables a user to return to the *Operator* page and re-access the previous menu (displayed at exit) without re-entering the password. For periods over 5-minutes (or if *Logout* is selected), a password must be re-entered to access protected levels.

5.5 Profile Operator page



Fig. 5.4 Profile Operator page

5.5.1 Profile Operator page menu functions

Menu	Description
Run	Start the selected profile program (from <i>Stop</i> or <i>Operator Hold</i>).
Stop	Stop a profile program that is running.
Reset	Restart the profile from the beginning of the program.
Hold	Pause the currently running program (<i>Operator Hold</i>).
Skip Segment	Abandon the current segment and start the next segment.
Repeat Segment	Return to the beginning of the current segment.
Fast Run Mode	Run the profile 8 times faster than normal rate.

Table 5.3 Profile Operator page menu functions

5.6 Operator page overviews

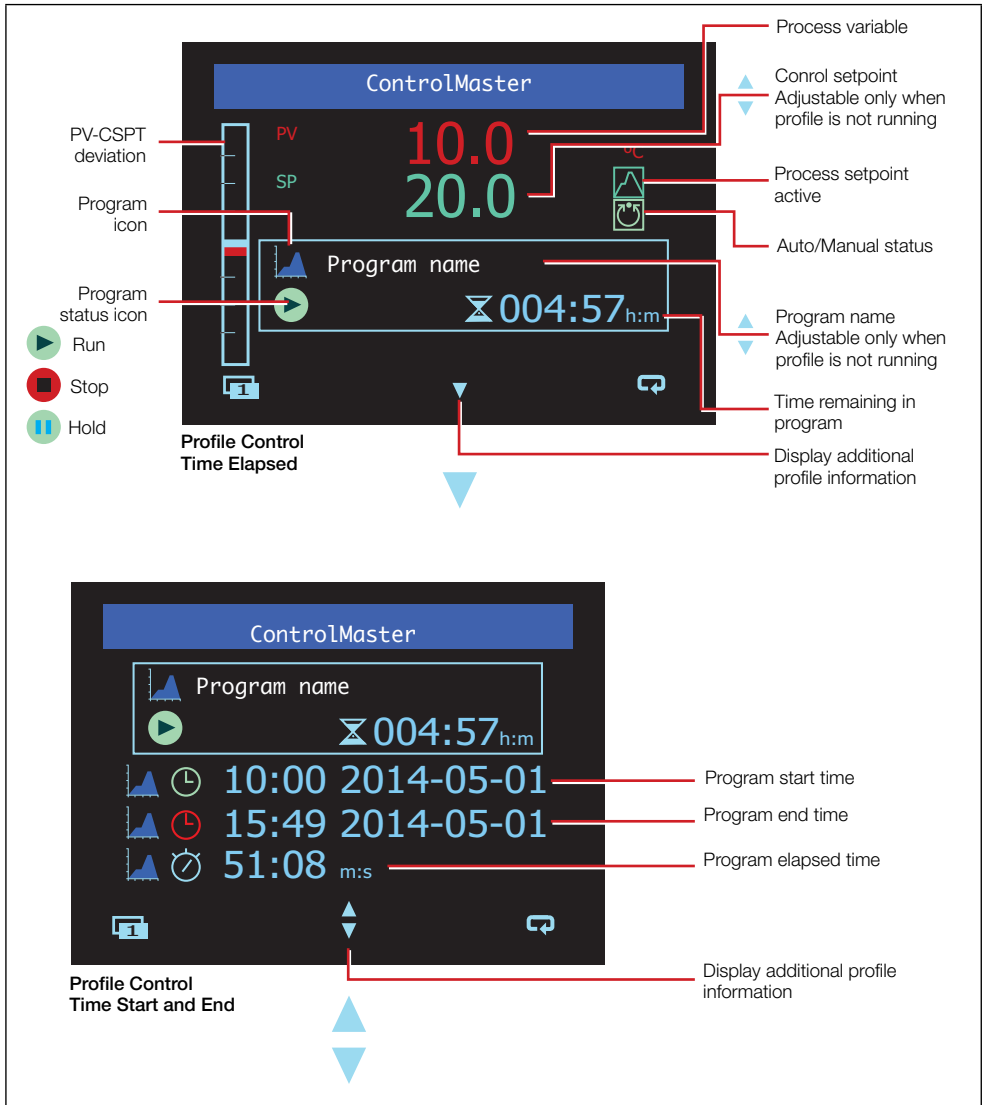

Fig. 5.5 Example Operator Page – Profile Control (Time Elapsed / Time Start and End)

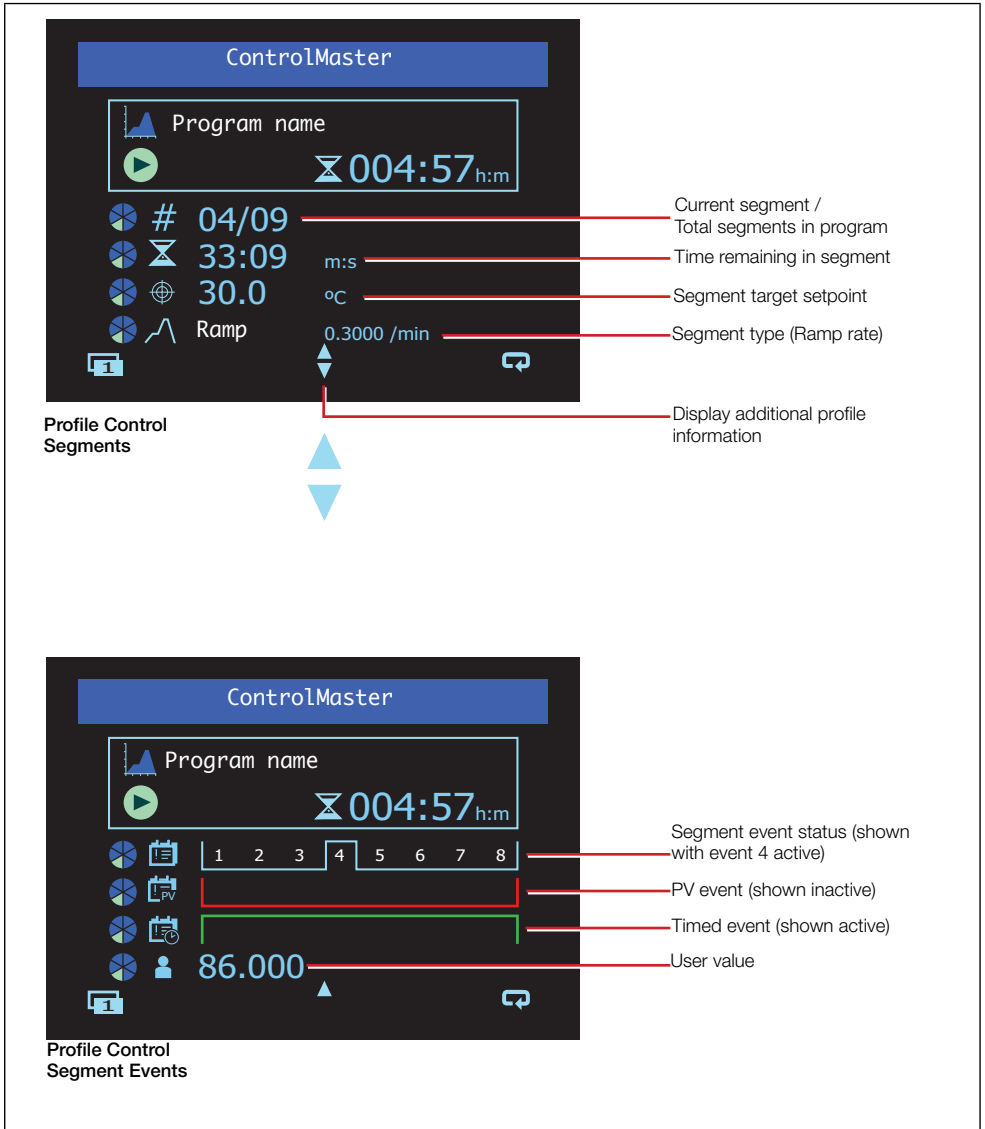
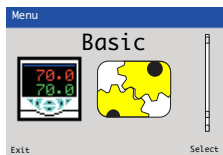

Fig. 5.6 Example Operator Page – Profile Control (Segments / Segment Events)

6 Basic Level



The *Basic* menu provides access to the tunable control settings and setpoint values.

Loop 1 (2) Setpoints

- Local Setpoint 1 (4)** The local setpoint value required. If this value is adjusted in the *Operator Level* (see page 23) its value in here is also updated.
- RSP Ratio** If the remote (external) setpoint is selected the control setpoint value is (ratio x remote setpoint input) + bias.
Note. This parameter is available only if the template selected has remote setpoint or if a ratio controller / station template is selected – see page 94.
- RSP Bias** Sets the remote setpoint bias in engineering units.
Note. This parameter is available only if template selected has remote setpoint or ratio.
- Ramp Mode** The ramping setpoint facility can be used to prevent a large disturbance to the control output when the setpoint value is changed. The rate set applies to both the local and the remote setpoints.

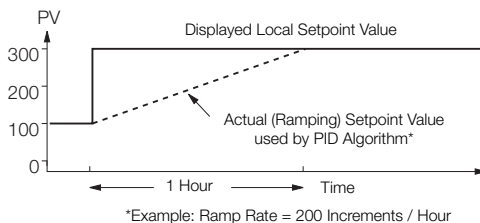

- Ramp Rate** Sets the ramp rate required in engineering units / hour.
Note. Applicable only if *Ramp Mode* is *On*.

...Basic

Loop 1 (2) Control

On/Off Hysteresis

Sets the hysteresis value in engineering units.

Note. Applicable only if *Control Type* is *On/Off* – see page 49.

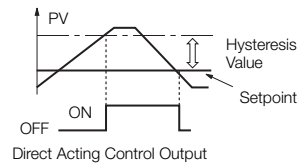
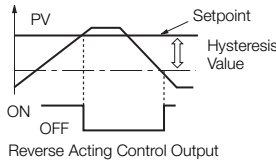

Mode

Turns the *Autotune* functionality on or off. When set to *On*, an *Autotune* can be started from the *Operator* level menus – see page 23.

Autotune

Autotune is a user-activated feature that enables automatic setting of the controller *PID* parameters (see page 30) using an 'at setpoint type' algorithm. *Autotune* changes the controller output and then monitors the process response to calculate the optimum *PID* settings. *Autotune* uses a relay-type function with hysteresis that initiates a controlled oscillation in the process. New *PID* parameters are calculated and stored in the controller automatically.

Note. To achieve the best results from *Autotune*, switch the controller to *Manual* control mode (see page 6) and adjust the output until the PV is stable (close to the normal setpoint) before initiating *Autotune*.

Autotune Operation

The *Autotune* sequence is shown in the following figure:

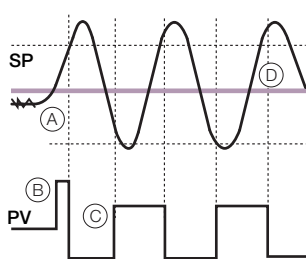

- ① Set the first step value and dynamics required. For best results, select the largest initial output step size that can be tolerated by the process.
- ② *Autotune* is enabled only if the control type is *PID*.
- ③ Start *Autotune* from the *Operator* menu.
- ④ Monitors a noise (A) and calculates a hysteresis value (1).
- ⑤ User-defined initial step in the output (B). When the process exceeds the hysteresis value the output is stepped down.
- ⑥ Adjusts output amplitude automatically (C) so PV disturbance is kept to minimum required.
- ⑦ When consistent oscillation is established (D), the *Autotune* process stops. Optimum settings are calculated from the process dynamics monitored.

...Basic / ...Loop 1 (2) Control / ... Autotune

First Step	Defines the maximum size of the first output step in the autotuning process. <i>Autotune</i> adjusts the output step magnitude according to the process noise and response to provide a reliable measurement of the process characteristics with the minimum disturbance of the process. The maximum setting provides the largest output step possible from the current output value.																								
Dynamics	Used to configure <i>Autotune</i> to give optimum results according to the type of process being controlled.																								
<i>Normal</i>	Determines if derivative control is required automatically and calculates the control settings accordingly.																								
<i>Deadtime</i>	Sets the proportional and integral terms to give optimum control for the deadtime process (higher proportional band [lower gain] and shorter integration time).																								
<i>PI</i>	Used for processes where it is known that derivative control is not required.																								
Reset	If the controller is transferred to another process or duty, <i>Autotune</i> must be reset. The current <i>PID</i> (see below) settings are retained but the internal process data is cleared ready for a completely new process with different characteristics.																								
PID	The controller's <i>PID</i> settings can be commissioned using the <i>Autotune</i> (see page 29) function and / or they can be adjusted manually. 3 Sets of parameters are provided to facilitate <i>Gain Scheduling</i> control – see page 50. When <i>Gain Scheduling</i> is not enabled, the first set of <i>PID</i> parameters only are used.																								
<i>Proportional Band 1</i>	Set as % of engineering range.																								
<i>Integral Time 1</i>	Set in seconds per repeat. To turn integral action off, set to 0 or 10000 s.																								
<i>Derivative Time 1</i>	Set in seconds. When using predictive control, <i>Derivative Time</i> becomes deadtime time constant.																								
<i>Manual Reset</i>	When the <i>Integral Time</i> is <i>Off</i> , the manual reset parameter is activated. When the process variable is equal to the control setpoint, the output value is equal to the manual reset value. Note: The controller is shipped with null <i>PID</i> values (P=100, I=off & D=0). To enable the controller to control the process it is connected to, these values must be tuned accordingly. This can be achieved via the <i>AutoTune</i> function or manual adjustment. If the controller is tuned manually the table below provides details of some suggested values to start from. These values are only suggested starting values and should not be used as an alternative to proper tuning of the Controller.																								
	<table border="1"> <thead> <tr> <th>Process Type</th> <th>P</th> <th>I</th> </tr> </thead> <tbody> <tr> <td>Temperature (fast)*</td> <td>10</td> <td>30</td> </tr> <tr> <td>Temperature (slow)*</td> <td>10</td> <td>300</td> </tr> <tr> <td>Pressure (fast)</td> <td>100</td> <td>1</td> </tr> <tr> <td>Pressure (slow)</td> <td>10</td> <td>30</td> </tr> <tr> <td>Level (fast)</td> <td>100</td> <td>1</td> </tr> <tr> <td>Level (slow)</td> <td>10</td> <td>30</td> </tr> <tr> <td>Flow</td> <td>100</td> <td>1</td> </tr> </tbody> </table>	Process Type	P	I	Temperature (fast)*	10	30	Temperature (slow)*	10	300	Pressure (fast)	100	1	Pressure (slow)	10	30	Level (fast)	100	1	Level (slow)	10	30	Flow	100	1
Process Type	P	I																							
Temperature (fast)*	10	30																							
Temperature (slow)*	10	300																							
Pressure (fast)	100	1																							
Pressure (slow)	10	30																							
Level (fast)	100	1																							
Level (slow)	10	30																							
Flow	100	1																							
	*For temperature loops, control performance can be improved via the use of <i>Derivative</i> . A suggested starting value is 1/6 th of the <i>Integral</i> value.																								
FeedForward	Applicable only if a <i>FeedForward</i> application template is enabled – see Section 8, page 88 for template details.																								
Gain	Sets the gain to be used when in <i>Static Gain</i> mode – see page 52. In <i>Adaptive Gain</i> mode this value is set automatically by the controller – see page 52.																								

...Basic

Loop 1 (2) Mot Valve ■

Motorized Valve Output With Feedback

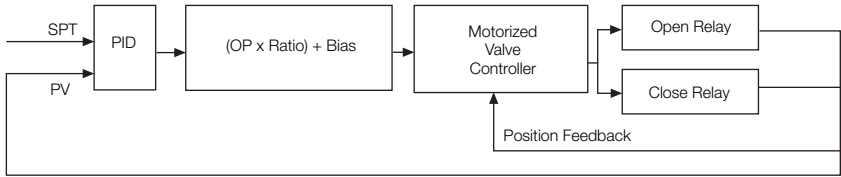

Motorized Valve Output Without Feedback (Boundless)

A motorized valve output without feedback (boundless) process controller provides an output that is effectively the time derivative of the required regulator position (the controller signals the regulator, not where to go to [position derivative], but in the direction to travel and how far to move) by a series of integral action pulses. Therefore, the controller does not need to know the absolute regulator position and is not affected when the regulator reaches the upper or lower limit, as determined by the regulator's limit switches (hence the term 'boundless').

When a deviation from setpoint is introduced, the regulator is driven for a length of time equivalent to the proportional step. The regulator is then driven by integral action pulses until the deviation is within the deadband setting.

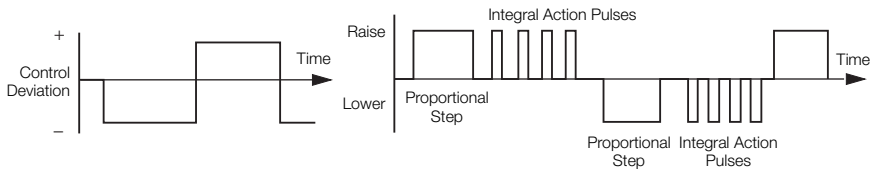

Ratio Bias The required valve position = (Ratio x PID O/P) + Bias.

Note. Ratio and Bias are applicable only to motorized valve with feedback – see above.

Deadband

With Feedback

The deadband is expressed as a % of the valve position. For example, if the valve is set to be driven to the 50 % open position and the deadband is set to 4 %, the motor stops driving at 48 %. The deadband is between 48 % and 52 %.

Without Feedback (Boundless)

The deadband is expressed in engineering units. For example, if the (Boundless) engineering range is 0 to 150 litres and the set point is 75 litres, when the deadband is set to 10 litres, the deadband is between 70 and 80 litres.

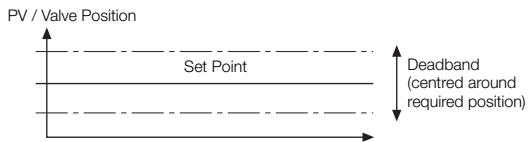

Travel Time

For motorized valve without feedback (see above), this parameter is used to control the valve movement.

For motorized valve with feedback, the time entered is compared with the actual valve movement. If the valve is sticking, a diagnostic message is generated (set *Travel Time* to 0 s to disable this feature).

...Basic / ...Loop 1 Mot Valve

Calculation for Control Pulses (Boundless Control)

The following calculations are for guidance when setting Deadband, proportional and integral values and are applicable only to Boundless control.

The Deadband on the ControlMaster is set in engineering units. To calculate the integral values, the engineering units must first be converted to a % using the following calculation:

$$\% \text{ Deadband} = \frac{\text{Deadband (eng units)}}{\text{Eng Hi} - \text{Eng Lo}} \times 100$$

The calculated % Deadband can now be used in the following integral action calculations:

Minimum 'ON' time of integral action pulses (for a fixed control deviation)

$$= \frac{\text{Travel Time} \times \% \text{ Deadband (in seconds)}}{\% \text{ Proportional Band}}$$

Minimum (approximate) time between integral action pulses (for a fixed control deviation)

$$= \frac{\text{Integral Action Time} \times \% \text{ Deadband (in seconds)}}{2 \times \text{Control Deviation}}$$

Duration of the proportional step

$$= \frac{2 \times (\% \text{ Control Deviation}) \times \text{Travel Time in seconds}}{(\% \text{ Proportional Band})}$$

% Control Deviation

$$= \frac{\text{Setpoint} - \text{Process Variable}}{\text{Eng Hi} - \text{Eng Lo}} \times 100\%$$

...Basic

Loop 1 (2) Time Prop

The active time of the output pulse is proportional to the value of the control output. With 100 % output the pulse is active for the complete cycle time, for example:

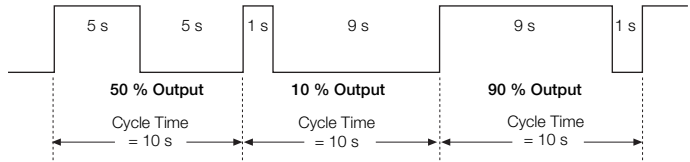

Note. Applicable only if *Output Type* is *Time Prop* or *Split Output* (and one output is a relay or a digital output) – see page 34.

Cycle Time 1

The cycle time to be used with time proportioning outputs. For *split outputs* this setting applies to *Output 1* – see page 34.

Cycle Time 2

The cycle time to be used with time proportioning outputs. For split outputs this setting applies to *Output 2* – see page 34.

Note. Applicable only if *Output Type* is *Split Output*.

Alarm 1 (8)

Trip

The alarm trip level in engineering units. See *Process Alarm* (page 58) for parameter details.

7 Advanced Level

7.1 Device Setup

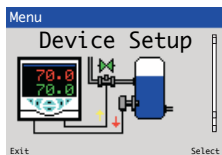

Provides access to standard setup parameters to determine the type of control / indication required. Also provides the ability to create non-standard configurations for special application requirements.

Initial Setup

App Template	<p>Application templates enable standard configurations for particular applications to be created as simply as possible. When a template is selected, the controller assumes the preset form for that template. The inputs and function blocks are soft-wired automatically to perform the selected function.</p> <p>See Section 8, page 88 for templates available to Extended and Dual functionality controllers.</p>
Loop 1 (2) Output Type	<p>The appropriate output function block, relay, digital and analog outputs are configured and soft-wired.</p> <p><i>Loop 2 Output Type</i> is available only if a <i>Dual Loop</i> application template is selected – see Section 8, page 88 for template details.</p> <p>See Appendix D, page 109 for output assignments.</p>
Loop 1 (2) Split O/P	<p><i>Loop 1 Split O/P</i> is available only if the <i>Loop 1 Output Type</i> is <i>Split Output</i>.</p> <p><i>Loop 2 Split O/P</i> is available only if a <i>Dual Loop</i> or <i>Cascade</i> application template is selected and the <i>Loop 2 Output Type</i> is <i>Split Output</i>.</p> <p>These types of outputs split the <i>Control (PID)</i> output signal (see page 30) into 2 signals. The linear relationship between the PID O/P and the 2 outputs can be configured in the <i>Control</i> configuration – see page 46.</p> <p>See Appendix D, page 109 for output assignments.</p>
Instrument Tag	<p>A 16-character alphanumeric tag, displayed in the title bar on <i>Operator</i> pages – see page 23.</p>
Loop 1 (2) Tag	<p>Available only if a <i>Cascade</i> or <i>Dual Loop</i> application template is selected – see Section 8, page 88 for template details.</p> <p>The tag is displayed in <i>Operator</i> pages – see page 23.</p>
Mains Freq	<p>Used to set the internal filters to reduce mains power frequency interference.</p>

...Device Setup / ...Initial Setup

Config Action	The <i>Config Action</i> parameter is used to determine how the controller and controller outputs behave when the <i>Advanced</i> level is entered – see page 34.
<i>Continue</i>	The controller continues to operate as in the operator level. Outputs continue to operate as normal.
<i>Hold</i>	Puts the controller into <i>Manual</i> control mode. When the <i>Advanced</i> level is exited, the controller returns to the pre-configuration mode of operation. Digital, relay and analog outputs are held at their value / state when configuration mode is entered.
<i>Inactive</i>	Puts the controller into <i>Manual</i> control mode. When the <i>Advanced</i> level is exited, the controller returns to the pre-configuration mode of operation. Digital and relay outputs are turned off. Analog outputs are set to 0 mA.
Custom Template ■	If this parameter is enabled, it enables the internal function blocks to be re-linked to create custom configurations for special application requirements. These sources are configured in <i>Device Setup / Custom Config</i> – see below.
Analog 1 Eng. Units Analog 2 Eng. Units	Configurable units that can be assigned to any analog signal (Analog I/P or Math Block).
Tot. 1 Eng. Units Tot. 2 Eng. Units	Configurable units that can be assigned to any totalizer.
Reset to Defaults	Resets all configuration parameters to their default values.
Security Setup	3 Security access levels are provided, each protected by a password of up to 6 alphanumeric characters. Note. Passwords <i>Basic</i> and <i>Advanced</i> level are not set at the factory and must be entered by the end user(s).
Basic Password	<i>Basic</i> level provides access to the <i>Basic</i> level parameters – see Section 6, page 28.
Advanced Password	Provides access to all configuration parameters – see Section 7, page 34.
Reset Passwords	Resets all passwords to factory values.

...Device Setup

Custom Config ■	
<i>Loop 1 (2) PV</i>	Sets the source for the process variable.
<i>Loop 1 (2) Split O/P</i>	Sets the source for output to the split output function block.
<i>Loop 1 (2) Valve Mode</i>	Sets the valve operation mode, <i>Feedback</i> or <i>Boundless</i> – see page 31.
<i>Loop 1 (2) Valve O/P</i>	Sets the control input to the valve function block.
<i>Loop 1 (2) Valve FB</i>	Sets the source for position feedback input.
<i>Loop 1 (2) TP OP1</i>	Sets the source for control input to the time proportioning block for <i>Output 1</i> – see page 34.
<i>Loop 1 (2) TP OP2</i>	Sets the source for control input to the time proportioning block for <i>Output 2</i> – see page 34.
<i>Loop 1 (2) RSP</i>	Sets the source for the remote (external) setpoint.
IrDA Configuration	
Allows the device configuration to be backed-up (read) from the device, or written to the device over the IrDA interface to a PC – see Section 9, page 97 – PC Configuration.	
Setup	
Select Mode	Select the <i>IrDA Configuration</i> operating mode.
<i>Off</i>	<i>IrDA Configuration</i> mode is turned off.
<i>Read-Only</i>	Enable reading of the device configuration.
<i>Read/Write</i>	Enable reading and writing of the device configuration.
Config. Description	A 24-character alphanumeric descriptor used to assist in identifying the configuration that is read from or written to the device.

7.2 Display

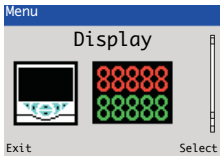

Used to setup the operator page, displayed language and display hardware settings.

Language	Selects the language on the controller's local display.
Operator Templates	Enables up to 4 operator pages to be configured to suit the application requirements.
Page 1 (4) Template	<p>The operator template type.</p> <p>The functions available in each template type are displayed as abbreviations, for example:</p> <p><i>Single PV, SP & OP</i></p> <p>Key to abbreviations:</p> <ul style="list-style-type: none">■ PV = process variable■ SP = setpoint■ MOP = master output (A/M status and analog backups)■ OP = control output■ DV = disturbance variable (input to feedforward)■ Overview = displays PV, SP and OP for both loops■ Loop 1 (2) = displays PV, SP and SP for Loop 1 (2)■ AR = actual ratio■ DR = desired ratio■ Chart = trend display of up to 2 signals■ Profiler = setpoint profile generator

...Display

Operator Functions	
Autoscroll	When enabled (<i>On</i>), <i>Operator</i> pages (see page 23) are scrolled continuously at intervals of 10 seconds per page.
Soft Key Function	Assigns a dedicated function to the Navigation key (right) – see page 6.
<i>Configuration</i>	Displays the <i>Access Level</i> enabling selection of configuration levels – see page 24.
<i>Auto/Manual</i>	Toggles between <i>Auto</i> and <i>Manual</i> control modes.
<i>Local / Remote</i>	Toggles between <i>Local</i> and <i>Remote</i> setpoint modes.
<i>Scroll View</i>	Scrolls through each available <i>Operator</i> view.
<i>Alarm Ack</i>	Acknowledges all active unacknowledged alarms.
<i>Toggle Signal</i>	Provides a source that toggles between 2 states – can be assigned to outputs or used to select sources.
<i>Edge Signal</i>	Provides an edge-triggered source that is active on key press. Can be assigned to outputs or used to select sources
Auto Manual Enable	Turns on / off the ability for <i>Auto / Manual</i> control mode to be changed in <i>Operator Level</i> .
Local Remote Enable	Turns on / off the ability for local / remote setpoint mode to be changed in <i>Operator Level</i> .
Alarm Ack. Enable	Turns on / off the ability to acknowledge alarms from the front panel.
Totalizer Stop/Go	Turns on / off the ability to start / stop the totalizer.
Totalizer Reset	Turns on / off the ability to reset the totalizer.
SP Adjust Enable	Turns on / off setpoint adjustment in the <i>Operator Level</i> .
Profiler ■	
<i>Select Program</i>	Enables the program to be selected in the <i>Operator Level</i> .
<i>Program Control</i>	Enables the program control functions to be available in the <i>Operator</i> menus (<i>Run, Stop, Hold, Reset</i>).
<i>Segment Control</i>	Enables the segment control functions to be available in the <i>Operator</i> menus (<i>Skip Segment, Repeat Segment</i>).

...Display

Chart View ▲	<p>Enables the operator level chart function to be configured.</p> <p>The chart can display the trend for 1 or 2 analog values and be scaled independently of the engineering ranges for the analog values selected.</p> <p>Note. Enabled only if <i>Operator Template, Chart</i> is selected – see page 37.</p>
<hr/>	
Channel 1 (2)	
Source	Selects the analog value to be shown on the chart – see Appendix A.2, page 105 for details of analog sources.
Scale Low*	Sets the minimum value on the y-axis for this channel.
Scale High*	Sets the maximum value on the y-axis for this channel.
Tag	A 3-character, alphanumeric tag used to identify the parameter on the chart.
Sample Rate	Selected from 1, 10, 30 seconds; 1, 2, 3, 4, 5 minutes.
<hr/>	
Settings	Adjusts display settings to suit ambient conditions.
Brightness	Increases / Decreases the display brightness to suit local environmental conditions.
Contrast	Increases / Decreases the display contrast to suit local environmental conditions (enabled for CM30 and CM50 only).
<hr/>	
Date & Time ■	Sets the date format, local time / date and daylight saving start / end times.
Date Format	Selected from: DD-MM-YYYY, MM-DD-YYYY, YYYY-MM-DD.
Time & Date	Sets the controller's time and date.
Daylight Saving	Sets daylight saving parameters.
<hr/>	
DS Region	
<i>Off</i>	Daylight saving is disabled.
<i>Europe</i>	Standard daylight saving start and end times are selected for Europe automatically.
<i>USA</i>	Standard daylight saving start and end times are selected for USA automatically.
<i>Custom</i>	Used to create custom daylight saving start and end times manually for regions other than Europe or USA.
	Note. Enables <i>Daylight Start Time</i> and <i>Daylight End Time</i> parameters.
<hr/>	
DS Start Time	The start time selected from 1-hour increments.
	Note. Displayed only when the <i>DS Region</i> sub-parameter is <i>Custom</i> .
DS Start Occur DS End Occur	The day within the month that daylight starts / ends – for example, to set daylight saving to start (or end) on the second Monday of the selected month, select <i>Second</i> .
DS Start Day DS End Day	The day of the month daylight saving starts / ends.
	Note. The <i>Daylight Start / End Occur</i> parameters must be valid within the month for the selected day.
DS Start Month DS End Month	The month daylight saving starts / ends.

*When the controller is setup for the first time, the *Scale Low* and *Scale High* values default to match the engineering range.

...Display

Customise Pages ▲	The contents and appearance of each <i>Operator Page</i> (see page 23) can be customized to meet particular user requirements.																																																						
Page Number	Selects the <i>Operator Page</i> (1 to 4) to be customized.																																																						
Template Type	Selects one of the standard operator page templates. Template codes: <hr/> A = Analog value, T = Totalizer value, S = State value (see <i>Parameters / Type</i> below). <table border="0"> <tr> <td>A (Style 1)</td> <td>A,A (Style 1)</td> <td>A,A,A (Style 1)</td> <td>A,A,A,A (Style 1)</td> <td>A,A,A,A,A</td> <td>A,A,A,A,A,A</td> </tr> <tr> <td>A (Style 2)</td> <td>A,A (Style 2)</td> <td>A,A,A (Style 2)</td> <td>A,A,A,A (Style 2)</td> <td>A,A,A,A,S</td> <td>A,A,A,A,A,S</td> </tr> <tr> <td></td> <td>A,A (Style 3)</td> <td>A,A,A (Style 3)*</td> <td>A,A,A,A (Style 3)</td> <td></td> <td>A,A,S,A,A,A</td> </tr> <tr> <td></td> <td>A,A (Style 4)</td> <td>A,A,A (Style 4)</td> <td>A,A,A,T**</td> <td></td> <td>A,A,S,A,A,S</td> </tr> <tr> <td></td> <td>A,T (Style 1)</td> <td>A,A,S (Style 1)</td> <td>A,A,T,T</td> <td></td> <td></td> </tr> <tr> <td></td> <td></td> <td>A,A,S (Style 2)</td> <td></td> <td></td> <td>Chart</td> </tr> <tr> <td></td> <td></td> <td>A,A,T</td> <td></td> <td></td> <td></td> </tr> <tr> <td></td> <td></td> <td>A,T,T</td> <td></td> <td></td> <td></td> </tr> <tr> <td></td> <td></td> <td>*CM50 only</td> <td>**CM30 only</td> <td></td> <td></td> </tr> </table> <hr/>	A (Style 1)	A,A (Style 1)	A,A,A (Style 1)	A,A,A,A (Style 1)	A,A,A,A,A	A,A,A,A,A,A	A (Style 2)	A,A (Style 2)	A,A,A (Style 2)	A,A,A,A (Style 2)	A,A,A,A,S	A,A,A,A,A,S		A,A (Style 3)	A,A,A (Style 3)*	A,A,A,A (Style 3)		A,A,S,A,A,A		A,A (Style 4)	A,A,A (Style 4)	A,A,A,T**		A,A,S,A,A,S		A,T (Style 1)	A,A,S (Style 1)	A,A,T,T					A,A,S (Style 2)			Chart			A,A,T						A,T,T						*CM50 only	**CM30 only		
A (Style 1)	A,A (Style 1)	A,A,A (Style 1)	A,A,A,A (Style 1)	A,A,A,A,A	A,A,A,A,A,A																																																		
A (Style 2)	A,A (Style 2)	A,A,A (Style 2)	A,A,A,A (Style 2)	A,A,A,A,S	A,A,A,A,A,S																																																		
	A,A (Style 3)	A,A,A (Style 3)*	A,A,A,A (Style 3)		A,A,S,A,A,A																																																		
	A,A (Style 4)	A,A,A (Style 4)	A,A,A,T**		A,A,S,A,A,S																																																		
	A,T (Style 1)	A,A,S (Style 1)	A,A,T,T																																																				
		A,A,S (Style 2)			Chart																																																		
		A,A,T																																																					
		A,T,T																																																					
		*CM50 only	**CM30 only																																																				
Titlebar Tag	A user-programmable, 16-character alphanumeric tag.																																																						
Parameters																																																							
Parameter Number	1 to 4 (depending on the <i>Template Type</i> selected).																																																						
Type	Enables some parameter types to be modified to enable more flexibility in the available display formats: <ul style="list-style-type: none"> ■ Parameters set as <i>Totalizer value</i> by the <i>Template Type</i> can be changed to analog or state parameters. ■ Parameters set as <i>State value</i> by the <i>Template Type</i> can be changed to an analog parameter. 																																																						
Source	Selects the signal to be displayed.																																																						
Color	Selects the color to be used to display this parameter. Color codes: <hr/> <table border="0"> <tr> <td>Black</td> <td>Red</td> <td>Yellow</td> <td>Green</td> <td>Cyan</td> </tr> <tr> <td>Blue</td> <td>Magenta</td> <td>White</td> <td>Grey</td> <td></td> </tr> <tr> <td>Dark Cyan</td> <td>Dark Magenta</td> <td>Dark Grey</td> <td>Dark Yellow</td> <td>Dark Green</td> </tr> <tr> <td>Dark Blue</td> <td>Dark Red</td> <td></td> <td></td> <td></td> </tr> <tr> <td>Theme RGB*</td> <td>Theme RYG**</td> <td></td> <td></td> <td></td> </tr> </table> <hr/> *For use with <i>State</i> parameter types: <ul style="list-style-type: none"> ■ State 0 tag is shown in red. ■ State 1 tag is shown in green. ■ State 2 tag is shown in blue. Applicable only if <i>Template Type</i> = <i>State</i> . **For use with <i>State</i> parameter types: <ul style="list-style-type: none"> ■ State 0 tag is shown in red. ■ State 1 tag is shown in yellow. ■ State 2 tag is shown in green. Applicable only if <i>Template Type</i> = <i>State</i> .	Black	Red	Yellow	Green	Cyan	Blue	Magenta	White	Grey		Dark Cyan	Dark Magenta	Dark Grey	Dark Yellow	Dark Green	Dark Blue	Dark Red				Theme RGB*	Theme RYG**																																
Black	Red	Yellow	Green	Cyan																																																			
Blue	Magenta	White	Grey																																																				
Dark Cyan	Dark Magenta	Dark Grey	Dark Yellow	Dark Green																																																			
Dark Blue	Dark Red																																																						
Theme RGB*	Theme RYG**																																																						

...Display / ...Customise Pages / ...Parameters ▲

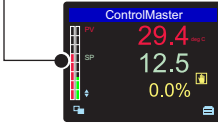
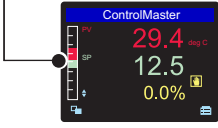
Tag	A user-programmable, 3-character alphanumeric tag used to identify each parameter.																								
State 0 Tag	A user-programmable, 8-character alphanumeric tag displayed when the state of the selected parameter has a value of 0.																								
State 1 Tag	A user-programmable, 8-character alphanumeric tag displayed when the state of the selected parameter has a value of 1.																								
State 2 Tag	A user-programmable, 8-character alphanumeric tag displayed when the state of the selected parameter has a value of 2.																								
<hr/>																									
Bargraphs	Up to 2 bargraphs can be configured. On some <i>Template Types</i> (see page 40), it is not possible to display one or both of the bargraphs.																								
Bargraph Number	Selects the bargraph to be customized.																								
Type	Selects the type of bargraph (if required). [Off, Standard, Deviation]																								
	<div style="display: flex; justify-content: space-around; align-items: flex-start;"> <div style="text-align: center;"> <p>Standard Bargraph (2 Shown)</p>  </div> <div style="text-align: center;"> <p>Deviation Bargraph</p>  </div> </div>																								
Source	Selects the analog signal to be represented on the bargraph (if a <i>Deviation</i> bargraph type is selected, select deviation signals only).																								
Color	Selects the color to be used on the bargraph. Note. <i>Theme RGB</i> and <i>Theme RYG</i> (see page 40) cannot be used with bargraphs.																								
<hr/>																									
Icons	Used to configure up to 8 icons (with some custom display templates it is not possible to display all 8 icons).																								
Type	Selects the type of icon to be displayed. Icon types:																								
	<table border="1" style="width: 100%; border-collapse: collapse;"> <tr> <td>Off</td> <td></td> <td></td> <td></td> </tr> <tr> <td>Loop 1 Local SP</td> <td>Loop 1 Auto/Manual</td> <td>Loop 1 Local/Remote</td> <td></td> </tr> <tr> <td>Loop 2 Local SP</td> <td>Loop 2 Auto/Manual</td> <td>Loop 2 Local/Remote</td> <td></td> </tr> <tr> <td>Loop 1 Feedforward</td> <td>Loop 2 Feedforward</td> <td>Loop 1 Valve Status</td> <td>Loop 2 Valve Status</td> </tr> <tr> <td>Loop 1 Totalizer</td> <td>Loop 2 Totalizer</td> <td>Loop 1 Ration L/R</td> <td>Loop 2 Ration L/R</td> </tr> <tr> <td>Loop 1 Track Status</td> <td>Loop 2 Track Status</td> <td>Blank</td> <td></td> </tr> </table>	Off				Loop 1 Local SP	Loop 1 Auto/Manual	Loop 1 Local/Remote		Loop 2 Local SP	Loop 2 Auto/Manual	Loop 2 Local/Remote		Loop 1 Feedforward	Loop 2 Feedforward	Loop 1 Valve Status	Loop 2 Valve Status	Loop 1 Totalizer	Loop 2 Totalizer	Loop 1 Ration L/R	Loop 2 Ration L/R	Loop 1 Track Status	Loop 2 Track Status	Blank	
Off																									
Loop 1 Local SP	Loop 1 Auto/Manual	Loop 1 Local/Remote																							
Loop 2 Local SP	Loop 2 Auto/Manual	Loop 2 Local/Remote																							
Loop 1 Feedforward	Loop 2 Feedforward	Loop 1 Valve Status	Loop 2 Valve Status																						
Loop 1 Totalizer	Loop 2 Totalizer	Loop 1 Ration L/R	Loop 2 Ration L/R																						
Loop 1 Track Status	Loop 2 Track Status	Blank																							
Color	Selects the color of each icon used on the display.																								
<hr/>																									
Page Colors	The <i>Icons</i> parameter is used to define the icons displayed and to select icon colors.																								
Background Color	Selects the background color of the <i>Operator Page</i> – see page 23.																								
Titlebar Color	Selects the background color of the title bar.																								
Title Tag Color	Selects the color of the title bar tag.																								
Softkey Color	Selects the color for the <i>Soft Key</i> icons – see page 38.																								

7.3 Input/Output

Enables analog and digital inputs / outputs and relays to be configured.

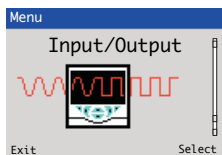

Analog Inputs

Analog Input 1 (4)*

Input Type *Millivolts, Milliamps, Volts, Resistance (Ohms), RTD, Thermocouple, Digital volt-free, 24V Digital, Freq. Input, Pulse Input.*

Additional *Input Type* comments:

Digital Volt Free Acts as a digital input.

Freq. Input Sets the maximum frequency and equivalent flow rate in the engineering range 0 to 6000 Hz. (A frequency of 0.01 to 6 KHz can be used to create an analog value.)

Pulse Input This parameter counts pulses and is recommended only for use with electromagnetic flowmeters.

Elect. Low Sets the required electrical range.

Note. Applicable only to *Millivolts, Milliamps, Volts* and *Ohms*.

Linear Inputs	Standard Analog Input	Accuracy (% of Reading)
Millivolts	0 to 150 mV	0.1 % or ±20 µV
Milliamps	0 to 45 mA (CM30 & CMF310) 0 to 50 mA (CM50)	0.2 % or ±4 µV
Volts	0 to 25 V	0.2 % or ±1 mV
Resistance Ω (low)	0 to 550 Ω	0.2 % or ±0.1 Ω
Resistance Ω (high)	0 to 10 kΩ	0.1 % or ±0.5 Ω

Elect. High Sets the required electrical range.

Note. Applicable only to *Millivolts, Milliamps, Volts* and *Freq. Input*.

Linearizer Selects the linearizer type required to condition the input signal.

Notes. For thermocouple applications using an external fixed cold junction, set *Input Type* to *Millivolts* and select the appropriate linearizer type.

Not applicable for *Pulse Input, Digital volt-free, 24V Digital* parameters.

Eng Units The selected units are used by the linearizer and displayed in the *Operator* pages.

Not applicable for: *Pulse Input, Digital volt-free, 24V Digital* parameters.

Thermocouple and RTD inputs are restricted to *deg C, deg F, Kelvin* – see Appendix C, page 108 for analog input (engineering) units.

Eng. Dps Engineering decimal places – selects the resolution required to be displayed for the input value.

*Analog Inputs 2 to 4: *Freq Input, Pulse Input* and *Resistance* not available. A *Thermocouple* input type can be set only if the first input is set to *Thermocouple*.

...Input/Output / ...Analog Inputs / ...Analog Input 1 (4)

Eng. Low	<p>Specifies the engineering low (minimum) value.</p> <p>For example, for an electrical input range of 4.0 to 20.0 mA, representing a pressure range of 50 to 250 bar, set the <i>Eng Low</i> value to 50.0 and the <i>Eng High</i> value to 250.0.</p> <p>Not applicable for <i>Pulse Input</i> – see page 42.</p>
Eng. High	<p>Specifies the engineering high (maximum) value.</p> <p>See <i>Eng Low</i> for range example.</p> <p>Not applicable for <i>Pulse Input</i>.</p>
Pulse Units	<p>Selects the unit of measure for the pulse input type.</p>
Pulse / Unit	<p>Sets the number of pulses required to represent 1 pulse unit (as set above).</p> <p>For example, if <i>Pulse Units</i> = Kl and <i>Pulse / Unit</i> = 10.00000000, each pulse represents 0.1 Kl, 10 pulses = 1 Kl.</p>
Broken Sensor	<p>If an input failure occurs, the input value can be configured to drive in a set direction.</p>
<i>None</i>	<p>No action taken.</p>
<i>Automatic</i>	<p>If the value of failed input is below <i>Eng Low</i>, the input value is driven to minimum downscale value; otherwise it is driven to the maximum upscale value.</p>
<i>Upscale</i>	<p>The input is driven to the maximum upscale value.</p>
<i>Downscale</i>	<p>The input is driven to the minimum downscale value.</p>
Filter Time	<p>The input is averaged over the time set.</p>
Fault Detect	<p>Sets a tolerance level (in % of engineering range) to allow for deviation of the input signal above or below the engineering range before an input failure is detected.</p>
Zero Adjustment Span Adjustment	<p>The <i>Zero Adjustment</i> and <i>Span Adjustment</i> parameters enable fine tuning of the inputs to eliminate system errors. Apply a known input value and adjust until the required input value is displayed.</p> <p>Normally, <i>Zero Adjustment</i> is used with input values close to <i>Eng Low</i> (adjustment is performed by applying an offset to the reading) and <i>Span Adjustment</i> is used with values close to <i>Eng High</i> (adjustment is performed by applying a multiplier to the reading).</p>

...Input/Output

Analog Outputs	The analog outputs can be configured to retransmit any analog value and have a configurable range from 0 to 24 mA. Output 1 can also be configured to function as a digital output.
Analog Output 1 (4)	Note. CM30 / 50: <i>Analog Output 2</i> available only if an option board is fitted – see pages 16 (CM30) and 17 (CM50) for option board details. CMF310: <i>Analog Outputs 3 / 4</i> available only if an optional <i>Output / Slope Relays</i> board is fitted – see page 20.
Output Type	Selects the output type required (applicable only to Analog Output 1).
Source	Selects the parameter to be assigned to the output – see Appendix A, page 104 for description of sources.
Elect. Low*	The current output required when the source value is equal to the <i>Eng Low</i> value – see page 43.
Elect. High*	The current output required when the source value is equal to the <i>Eng High</i> value – see page 43.
Auto Eng Range*	If enabled (<i>On</i>) the <i>Eng High</i> and <i>Eng Low</i> values for the output are set automatically to the engineering range values of the source.
Eng Low*	The minimum engineering range output value.
Eng High*	The maximum engineering range output value.
Polarity**	Sets the polarity of the output signal. If set to <i>Negative</i> , the output is energized when source is inactive. If set to <i>Positive</i> , the output is energized when source is active.

*Not applicable if *Output Type* is *Digital* or *Source* is *None*.

**Not applicable if *Output Type* is *Analog* or *Source* is *None*.

...Input/Output

Digital I/O	
Digital IO 1 (6)	
Type	Sets the <i>Digital IO</i> to operate as an output or an input.
<i>Off</i>	No action taken.
<i>Output</i>	The <i>Digital IO</i> operates as an output.
<i>Volt Free</i>	High input detected when volt free switch across input is closed.
<i>24 Volt</i>	Digital input low <5V, high> 11 V (maximum input 30 V).
<i>TTL</i>	Digital input low <0.8V, high> 2 V.
Output Source	Selects the digital signal to be assigned to the output – see Appendix A.1, page 104 for description of sources.
Polarity	Sets the polarity of the output signal.
<i>Positive</i>	For an output, if the source is active the output is high. For an input, if a high signal is detected the input is active.
<i>Negative</i>	For an output, if source is inactive the output is high. For an input, if a low signal is detected the input is active.
Relays	
Relay 1 (4 – CM30/50)	
Relay 1 (6 – CMF310)	
Source	Selects the digital signal to be assigned to the relay – see Appendix A.1, page 104 for description of sources.
Polarity	Sets the polarity of the relay.
<i>Positive</i>	If the source is active the relay is energized.
<i>Negative</i>	If the source is inactive the relay is energized.

7.4 Control

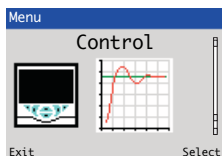

Enables the setpoints, control functions and outputs to be configured.

Loop 1 (2) Setpoints

The controller can have up to 4 independent local setpoint values, remote setpoint functionality and the ability to limit the absolute values and rate of change of the control setpoint.

Loop 2 Setpoint settings apply to the slave controller if a *Cascade* application template is selected – see Section 8, page 88 for template options.

Note. This section is not applicable for *Auto/Manual Station*, *Single & Dual Indicator*, *Ratio Station templates* – see Section 8, page 88 for template options.

Low Limit High Limit

The setpoint limit parameters define the maximum and minimum values for the local and/or remote setpoints. The setpoint limits do not apply when in *Manual* control mode with local setpoint tracking enabled. If the setpoint is outside of limits when *Auto* control mode is selected, the setpoint value can be adjusted only towards its limits.

Once within the limits they apply as normal.

No. of Local SP's

Selects the number of independent local (internal) setpoints required.

The local setpoints can be selected from the *Operator* level menu or via a digital signal.

Local Setpoint 1 (4)

If the value is adjusted in the *Operator* level, its value here is also updated.

Track Mode

The local (internal) setpoint can track another value according to the setpoint tracking mode selected.

Off

No tracking.

Local

The local (internal) setpoint tracks the process variable when *Manual* control mode is selected.

Remote

The local (internal) setpoint tracks the remote (external) setpoint when in *Remote Setpoint* mode. If the controller is put into *Manual* control mode the setpoint reverts from *Remote* to *Local*. This also applies to the local and remote ratio when a ratio controller template is selected – see Section 8, page 88 for template details.

Note. Available only if the template selected has remote setpoint or ratio functionality.

Local and Remote

Note. Available only if the template selected has remote setpoint or ratio functionality.

...Control / ...Loop 1 (2) Setpoints

RSP Ratio	When the remote (external) setpoint is selected the control setpoint value is: (ratio x remote setpoint input) + bias	
RSP Bias	Sets the remote setpoint bias in engineering units – see Appendix C, page 108 for description of analog input (engineering) units.	
RSP Fault Action	The action required when a fault occurs with the remote setpoint.	
<i>No Action</i>	No fault action.	
<i>Local</i>	Selects the local (internal) setpoint mode.	
<i>Local Default</i>	Selects the local (internal) setpoint mode and sets its value to the default setpoint.	
Default Setpoint	Sets the value required for the local (internal) setpoint under remote setpoint fault conditions.	
Ramp Mode	The ramping setpoint facility can be used to prevent a large disturbance to the control output when the setpoint value is changed. The rate set applies to both the local and the remote setpoints.	
	<p style="text-align: center;">*Example: Ramp Rate = 200 Increments / Hour</p>	
Ramp Rate	Sets the ramp rate required in engineering units / hour	
Select Sources	The selection of local setpoints and the changing of setpoint mode between local (internal) and remote (external) can be controlled by digital signals; either from internal digital signals (for example, alarm states) or from external signals via digital inputs (or digital communications) – see Appendix A.1, page 104 for description of sources.	
LSP 1/2 Toggle	The source required to select either local setpoint 1 (LSP1) or local setpoint 2 (LSP2). This source is level-triggered. A low signal locks the local setpoint as local setpoint 1 (LSP1) and a high signal locks it as local setpoint 2 (LSP2).	
LSP1 (4) Select	The source required to select local setpoint 1 (LSP1) as the current local setpoint. Selection is made on the rising edge of the digital signal.	
Local Select	The source required to select local setpoint mode (or local ratio mode when the ratio controller / station template is selected).	

...Control / ...Loop 1 (2) Setpoints / ...Select Sources

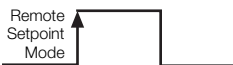
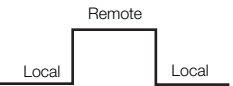
Remote Select	The source required to select remote setpoint mode (or remote ratio) mode.	
Loc/Rem Toggle	<p>The source required to select either local or remote setpoint mode. This source is level-triggered.</p> <p>A low signal locks the controller in local setpoint mode and a high signal locks it in remote setpoint mode. The edge-triggered local and remote selection sources and the front panel keys do not operate when this function is used.</p> <p>If the remote setpoint fails while selected using this digital selection and the <i>RSP Fault Action</i> parameter is not set to <i>No Action</i> (see page 47) the mode changes to <i>Local</i>.</p> <p>As soon as the remote setpoint is no longer in a failed state it reverts to remote mode (if it is still selected by this function).</p>	

Loop 1 (2) Control

Overview

Loop Control configures the basic type of control required and the *PID* and Autotune settings.

The controller can be configured to perform different types of control:

On/Off Control – see page 49

Simple 2-state thermostat-type control with configurable hysteresis to prevent wear on the final control element. This control type does not use *PID* control algorithm (see page 30) and can be used where precise control is not required or the process is very easy to control.

Note. Available only when the *O/P* type is set to time proportioning – see page 33.

PID (Proportional, Integral and Derivative) Control with Fixed Parameters – see page 30

If the process is linear (its dynamic characteristics are independent of the working point) and do not change with time, *PID* with fixed parameters can be used.

Gain Scheduling PID Control – see page 50 ■

If the process involves a non-linear valve or other type of non-linear device, the process dynamics change according to the working range (it is non-linear). Therefore, the controller also requires different parameters in different working ranges. If the non-linearity can be related to a reference signal, *PID* control with *Gain Scheduling* can be used. For instances where the process dynamics also vary with time it can be combined with adaptive control.

pPI (Predicting Proportional plus Integral) Control – see page 49 ▲

This is a deadtime-compensating controller. the *pPI* controller provides short damping-time at a load or setpoint change. *pPI* cannot be used with the *Autotune* (see page 29) or *Adaptive Control* (see page 52) and should not be used with integrating processes. *pPI* can be used with *Gain Scheduling* for applications where the deadtime is varying in relation to another parameter, for example, with the rate of flow or conveyor belt speed.

Feed Forward Control – see page 51 ▲

To eliminate a disturbance that could be measured before it affects the process value use a *FeedForward* template (see page 88 for template options). To eliminate the measurable levels of disturbance, *FeedForward Adaptive Gain* or *Static Gain* can be used – see Section 8, page 51.

Adaptive Control – see page 52 ▲

PID control with adaptive *PID* settings. If the process has variable dynamic characteristics that cannot be related to a reference signal, use *PID* control with adaptive *PID* settings.

The *Autotune* function can be used to set the *PID* parameters for all types of control except *pPI*. If Adaptive control is selected, these *PID* parameters are used as starting values only.

...Control / ...Loop 1 (2) Control

<p>Control Type</p> <p>PID</p> <p>pPI ▲</p>	<p>Selects the basic type of controller required.</p> <p>Standard proportional, integral and derivative control.</p> <p><i>pPI</i> controller:</p>
---	--

pPI (predictive PI control) is a deadtime-compensating control for use when the process deadtime is longer than twice the dominant process time constant. Unlike other deadtime compensation algorithms, *pPI* does not require a process model to be specified; it creates its own process model from proportional, integral and deadtime settings. If the deadtime is varying, the *pPI* controller can be combined with gain scheduling. The *Autotune* function is not used when *pPI* control is configured.

The *pPI* controller is easy to tune, first by making a step response test on the process and then setting the controller parameters by observation. After tuning, the *pPI* controller can be adjusted manually. In most cases a decrease in proportional band or a decrease in integral time gives faster control but poorer damping.

From a steady state condition, make a step change in the output from the neutral value (u_0) to a new value (u_1). Observe the process value (y) and make the following calculations:

$$\Delta y = y_1 - y_0$$

$$\Delta u = u_1 - u_0$$

$$T = t_2 - t_1$$

$$L = t_1 - t_0$$

By determining the 4 key parameters: L , T , Δy and Δu from a step response, the 3 process parameters: static gain K_p , dominant time constant T_p and deadtime L_p can be determined according to the following expressions:

$$K_p = \frac{\Delta y}{\Delta u} \quad T_p = T \quad L_p = L$$

Knowing these, the *pPI*'s parameters can be calculated easily:

- Proportional band = $100 \times K_p$
- Integral time = T_p
- Derivative (deadtime) = L_p

Notes.

y_0 and y_1 are expressed in % of engineering range.

When *pPI* is selected, the derivative time is used to set the deadtime.

On/Off

A simple 2-state control.

...Control / ...Loop 1 (2) Control

Control Action	If the required controller action is known it can be set using this parameter. Otherwise it can be set to <i>Unknown</i> and <i>Autotune</i> (see page 29) determines and selects the correct action.
<i>Direct</i>	For applications where an increasing process variable requires an increasing output to control it.
<i>Reverse</i>	For applications where an increasing process variable requires a decreasing output to control it.
<i>Unknown</i>	For applications where the control action is not known (run <i>Autotune</i> to set the control action automatically).

On/Off Hysteresis
Autotune Refer to *Basic* Level on page 28.
PID

Gain Scheduling ■

Gain Scheduling is used to improve the control of non-linear processes where the non-linearity is not time dependent. Processes with time-dependent non-linearity can be controlled with adaptive control. The gain scheduler selects different *PID* parameters (see page 30) according to the value of a user-selected reference signal.

3 Different settings for *PID* parameters can be used, within 3 ranges set by the user-defined parameters (*Limit 1* and *Limit 2* [see page 51]) that are expressed in the engineering range of the *Gain Scheduling* (GSRef) reference signal. When the value of the reference signal passes one of the limits the next set of *PID* parameters is switched in.

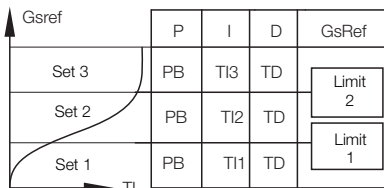

How Gain Scheduling Works with Autotune

When tuning is first performed, or after *Gain Scheduling* (or *Autotune* [see page 29]) is reset, the autotuner calculates *PID* parameters for the set selected by the GSRef signal and also copies those values into the other 2 sets of *PID* parameters.

If *Autotune* is then run with *Gain Scheduling* in one of the other 2 sets (see chart above), it calculates the *PID* values for the set selected by GSRef and also copies these to the set that was not calculated before.

If the *Autotune* is run with GSRef in the third set, it calculates the *PID* values for that set and leaves the other 2 sets untouched.

Any further running of the autotuner updates only the set that is selected at the time until *Gain Scheduling* (or *Autotune*) is reset. For example:

- If *Autotune* is run with $GSRef < Limit\ 1$, it calculates values for the first set of *PID* parameters and also copies these into the other 2 sets as well.
- If *Autotune* is then run with $GSRef > Limit\ 2$, it calculates *PID* values for the third set of *PID* parameters and also copies these to the second set.
- If *Autotune* is then run with GSRef between *Limit 1* and *Limit 2*, it calculates values for the second set of *PID* parameters and leaves the other 2 sets untouched.

...Control / ...Loop 1 (2) Control / ...Gain Scheduling

Mode	Turns the gain scheduling function <i>On</i> or <i>Off</i> .
Source	The <i>Gain Scheduling</i> (GSRef) reference signal – see Appendix A, page 104 for description of sources.
Limit 1 (2)	<i>Limit 1</i> – sets the point where the gain scheduler switches between the first and second sets of <i>PID</i> parameters. <i>Limit 2</i> – sets the point where the gain scheduler switches between the second and third sets of <i>PID</i> parameters
Reset	If the gain scheduler is reset, the next time <i>Autotune</i> (see page 29) is used all 3 sets of the <i>PID</i> parameters are set – see page 30.

FeedForward ▲

FeedForward can be used to eliminate disturbances that can be measured before they affect the process variable. *Feedforward Adaptive Gain* or *Static Gain* can be used to eliminate these measurable disturbances – see below.

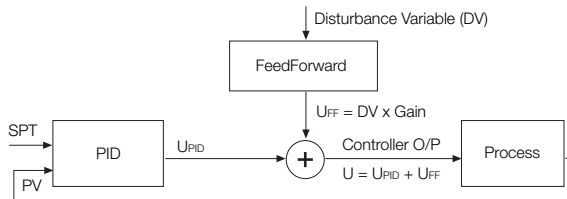

Note. *FeedForward* is enabled only if a *FeedForward* application template is enabled – see Section 8, page 88 for template options.

Calculating Static Gain

If the parameter mode is set to *Static Gain* (see page 52) the gain value can be determined using the following procedure:

- 1 Disable the *FeedForward* function by setting *Mode* to *Off* – see page 52.
- 2 Bring the system to a steady state.
- 3 Take note of the values of the disturbance variable (see DV, above) and the Controller output (identify them as v1 and u1 respectively).
- 4 Introduce a process disturbance, for example, by changing the process load, and then wait until the system is in a steady state.
- 5 Take note of the values of the *Disturbance Variable* and the Controller output (identify them as v2 and u2 respectively).
- 6 Use the following formula below to calculate the value of the *Static Gain* parameter:

$$\text{Gain} = \frac{U_1 - U_2}{V_1 - V_2}$$

- 7 Enable the *FeedForward* function by setting *Mode* to *Static Gain* – see page 52.

...Control / ...Loop 1 (2) Control / ...FeedForward ▲

Mode	
<i>Off</i>	Feedforward control is disabled.
<i>Static Gain</i>	Gain applied by <i>FeedForward</i> block is a fixed value set by the user.
<i>Adaptive Gain</i>	Gain applied by the <i>FeedForward</i> block is set by the controller automatically. <i>Adaptive</i> feedforward can be used even if <i>Adaptive Control</i> (see page 52) has not been enabled. For <i>Adaptive</i> feedforward to operate, the system must first be tuned using <i>Autotune</i> – see page 29. <i>Adaptive Gain</i> cannot be used with output tracking or with motorized valve without feedback. <i>FeedForward</i> (see page 51) with static gain can be used with motorized valve without feedback. <i>Adaptive Gain</i> cannot be used with <i>pPI</i> control – see page 49.
Source	
	Used to select source of the disturbance variable (DV) – see Appendix A, page 104 for description of sources.
Gain	
	Sets the gain to be used when in <i>Static Gain</i> mode. In <i>Adaptive Gain</i> mode this value is set automatically by the controller.
Reset Adaptive FF	
	If the controller is moved to another application, <i>Adaptive</i> feedforward must be reset.
Adaptive Control ▲	
<p><i>Adaptive Control</i> alters the <i>PID</i> parameters automatically (see page 30) if the process changes. It monitors process performance continuously and updates an internal process model. Based on this process model it calculates the optimum control parameters and adapts the <i>PID</i> settings accordingly. Changes to the <i>PID</i> settings occur as soon as the process dynamics change.</p> <p>Warnings are provided if the control parameters are changed by more than a set amount. This is important to detect conditions such as a blocked valve that could be interpreted by the adaptive controller as decreased process gain.</p> <p>Run <i>Autotune</i> (see page 29) to set the initial values for the adaptive controller. In a few cases, <i>Autotune</i> may not work well, for example in extremely noisy processes. In these cases, provide the adaptive controller with initial values of <i>Critical Period</i> and <i>Critical Gain</i> by the user – see procedure below.</p> <p>The adaptive controller uses the <i>Autotune Dynamics</i> setting to determine the optimum <i>PID</i> settings. If the process has a long deadtime, or a noisy measuring signal, select <i>Deadtime</i> or <i>PI</i> at the <i>Dynamics</i> parameter – see page 30.</p> <p>The adaptive controller does not work with Motorized Valve without Feedback output types – see Appendix D, page 109.</p> <p><i>Adaptive Control</i> cannot be used if output tracking mode <i>In Auto</i> is set (see page 56) because the adaptive controller receives false information.</p>	

...Control / ...Loop 1 (2) Control / ...Adaptive Control ▲

Mode	Turns adaptive control <i>On</i> or <i>Off</i> .
Critical Gain	Normally set by the autotuner, but can be set manually if necessary. A valid setting must be entered (either manually or using <i>Autotune</i> [see page 29] for the adaptive controller to function.
Critical Period	
	<p>Manual Calculation of <i>Critical Gain</i> and <i>Critical Period</i></p> <ol style="list-style-type: none"> 1 Put the controller into <i>Manual</i> control mode. 2 Set the integral and derivative terms to off. 3 Set the <i>Proportional Band</i> to 100 % – see page 30. 4 Adjust the controller's output signal manually until the process variable equals the setpoint. 5 Read the current controller output value. 6 Set the controller's <i>Manual Reset</i> parameter to the value of the output – see page 30. 7 Put the unit into <i>Auto</i> control mode. 8 Change setpoint by a few percent (as the setpoint is changed in each iteration, keep the value relatively constant by alternating increases with decreases). 9 Observe the process variable and the output signal to see if the system oscillates. 10 If the system oscillates with a decreasing amplitude, decrease the proportional band and go to step 8. 11 If the system oscillates with a increasing amplitude, increase the proportional band and go to step 8. 12 If the system oscillates with a constant amplitude, read the controller's oscillation period time. This is the setting of the <i>Critical Period</i> parameter. <p>Read the proportional band (Pb) setting and calculate the <i>Critical Gain</i> (Kc) as follows:</p> $K_c = \frac{100}{P_b}$
Reset	Resets the adaptive controller's internal parameters and process model to their default settings.
Misc.	
Loop Monitor	A control loop performance monitor can be enabled to monitor the control loop for abnormal oscillations and creates a diagnostic warning if any occur. This function is automatic and does not require any user set up after it is activated.
RSP Step Action	Remote setpoint step behavior. Determines how the <i>PID</i> (see page 30) algorithm responds to a step change in the remote setpoint value.
<i>No P&D</i>	During a step change in the remote setpoint value, the integral term only is applied.
<i>P&D</i>	During a step change in the remote setpoint value proportional, integral and derivative terms are applied.

...Control / ...Loop 1 (2) Control

Loop 1 (2) Output	Used to set the output limits, tracking rates, slew rates and output action on power failure or process variable failure.
Limits	When used with split output the limits restrict the <i>PID</i> algorithm output (see page 30) before the split output range values are calculated.
Limit Action	Selects when the output limits should be applied (<i>Off, Auto + Manual, Auto Only</i>).
Low Limit	Set minimum controller output in %.
High Limit	Set maximum controller output in %.
Failure Actions	
Power Recovery	Used to select the default power failure mode required following a power interruption or failure.
<i>Last Mode</i>	The last <i>Power Recovery</i> mode selected.
<i>Man – Last</i>	<i>Manual</i> control mode using the last output before power failure.
<i>Man – 0 %</i>	<i>Manual</i> control mode with output set to 0 %.
<i>Man – 100 %</i>	<i>Manual</i> control mode with output set to 100 %.
<i>Man – Default</i>	<i>Manual</i> control mode with output set to default value.
<i>Auto Mode</i>	<i>Auto</i> control mode with integral term reset.
<i>Auto – Last</i>	<i>Auto</i> control mode with integral term restored to its last value before the power failure.
<i>Timed – Last</i>	If the power outage is < recovery time, the control mode before power down is selected. If the power outage is > recovery time, <i>Manual</i> control mode (<i>Man – Last</i>) is selected using the last output before the power failure.
<i>Timed – Default</i>	If the power outage is < recovery time, the control mode before power down is selected. If the power outage is > recovery time, <i>Manual</i> control mode (<i>Man – Last</i>) is selected using the default output value.
<i>Recovery Time</i>	Set time in seconds for use with Timed power recovery.
PV Fail Action	Determines the controller output when the process variable input fails.
<i>No Action</i>	No action is taken if the process variable input fails.
<i>Man – Hold O/P</i>	Puts the controller into <i>Manual</i> control mode and holds the output at its value immediately prior to the PV failure.
<i>Man – Default O/P</i>	Puts the controller into <i>Manual</i> control mode and sets the output to the default output value.
Default Output	This parameter is used in conjunction with <i>Power Recovery</i> (see page 54) and <i>PV Fail Action</i> settings (see above). For split output this value refers to the <i>PID</i> algorithm (see page 30) before the split range values are calculated.

...Control / ...Loop 1 (2) Output

A/M Select Sources	Selection of <i>Auto</i> and <i>Manual</i> control modes can be controlled by digital signals; either from internal digital signals (for example, alarm states) or from external signals via digital inputs (or digital communications).	
Auto Select	The source required to select <i>Auto</i> control mode. Selection is made on the rising edge of the digital signal.	
Manual 1 (2) Select	The source required to select <i>Manual</i> control mode. Selection is made on rising edge of the digital signal. The output value is set according to <i>Manual 1 (2) Output</i> .	
Manual 1 (2) Output	Determines the Manual output value to be set when the controller is put into <i>Manual</i> control mode (see page 5) using <i>Manual 1 (2) Select</i> source.	
<i>Last Auto O/P</i>	Holds the output at its value prior to switching to <i>Manual</i> control mode.	
<i>Man – 0%</i>	Sets the output to 0 %.	
<i>Man – 100%</i>	Sets the output to 100 %.	
<i>Config Value</i>	Sets the output to the value set in <i>Manual 2 Output</i> .	
Manual 1 (2) Config O/P	Used when <i>Manual 1 (2) Output</i> is set to <i>Config Value</i> .	
A/M Toggle	The source required to toggle between <i>Auto</i> and <i>Manual</i> control modes. When the digital signal is high the controller is locked in <i>Manual</i> control mode (front panel keys [see page 5] and other digital select signals have no effect). When the digital signal is low <i>Auto</i> control mode is selected. When in the low state, either the front panel keys (see page 5) or edge-triggered digital signals can be used to put the controller into <i>Manual</i> control mode.	
A/M Output	Sets the manual output value to be set when the controller is put into <i>Manual</i> control mode using <i>A/M Toggle</i> source.	
<i>Last Auto O/P</i>	Holds the output at its value prior to switching to <i>Manual</i> control mode.	
<i>Man – 0%</i>	Sets the output to 0 %.	
<i>Man – 100%</i>	Sets the output to 100 %.	
<i>Config Value</i>	Sets the output to the value set in <i>A/M Config O/P</i> .	
<i>A/M Config O/P</i>	Used when <i>A/M Output</i> is set to <i>Config Value</i> .	
Slew Rate	The output slew rate – restricts the maximum rate of change of the control output.	
Function	Selects if the output slew rate function is enabled and when it applies.	
<i>Off</i>		
<i>Up and Down</i>	The <i>Slew Rate</i> applies to increasing and decreasing output values.	
<i>Up</i>	The <i>Slew Rate</i> applies to increasing output values only.	
<i>Down</i>	The <i>Slew Rate</i> applies to decreasing output values only.	

...Control / ...Loop 1 (2) Output

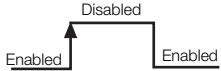
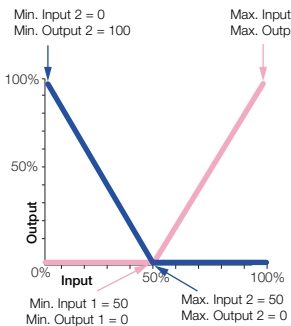
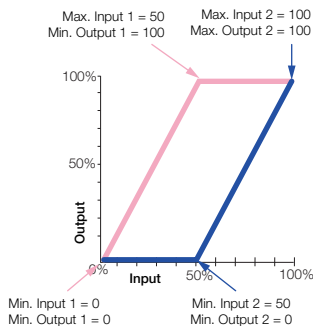
Rate	The maximum rate of change of the control output (% / s).
Disable Source	The source required to disable slew rate control of the output. This source is level-triggered.
	
Tracking	<p>Enables the control output to be configured to follow a tracking signal when in <i>Auto</i> control mode. When in <i>Manual</i> control mode the output can be adjusted by the user as normal. If the slew rate function is enabled, switching from <i>Manual</i> to <i>Auto</i> is bumpless. If the value set by the tracking signal is different to that set manually, the output ramps to its expected auto value at the speed set in the slew rate.</p> <p>If the <i>Signal Source</i> is set to <i>None</i> tracking is disabled and the normal <i>PID</i> output is provided as the control output.</p>
Source Signal Source	Sets the source of the signal required to be tracked by the output in <i>Auto</i> control mode. If set to <i>None</i> , output tracking is disabled.
Mode	Selects the type of output tracking.
<i>In Auto</i>	Control output = tracking signal when in <i>Auto</i> control mode.
<i>Auto + OP</i>	Control output = tracking signal + change in <i>PID</i> output, when in <i>Auto</i> control mode.
<i>When Enabled</i>	When enable source is active, Control output = tracking signal when in <i>Auto</i> control mode.
<i>When Enabled + OP</i>	When enable source is active, Control output = tracking signal + change in <i>PID</i> output, when in <i>Auto</i> control mode.
Enable Source	Sets the digital signal to enable output tracking.
	Note. Applicable only if <i>Mode</i> is <i>When Enabled</i> or <i>When Enabled + OP</i> .
Loop 1 (2) Split O/P*	<p>This facility enables the <i>PID</i> control output (see page 30) to be split into 2 separate outputs. This enables heat / cool and other applications requiring dual outputs to be controlled. The linear relationship between the input from the <i>PID</i> algorithm and the 2 outputs is configured using the <i>Min/Max Input/Output</i> parameters (below).</p> <p>When operating with <i>Split O/P</i> in <i>Manual</i> control mode, manual adjustment is made to the input at the split output block (x axis). By default, the <i>Operator</i> page displays both output values (OP1 and OP2).</p> <p>*Applicable only if the output type selected is <i>Split O/P</i> – see page 34.</p>
	<div style="display: flex; justify-content: space-around;"> <div style="text-align: center;">  <p>Heat / cool example</p> </div> <div style="text-align: center;">  <p>Split output example</p> </div> </div> <div style="text-align: center; margin-top: 10px;"> ■ Output 1 (OP1) ■ Output 2 (OP2) </div>

...Control /...Loop 1 (2) Output

Loop 1 (2) Valve ■	See <i>Basic</i> level, page 28.
Loop 1 (2) Time Prop ■	See <i>Basic</i> level, page 28.
Output Switching	<p>The <i>Output Switching</i> functionality extends the duty/assist strategy that can be implemented with <i>Split Output</i> to include the ability to select which output is acting as the duty and which is the assist. Switching between the two outputs is controlled via a configurable digital input which swaps the outputs on a rising edge.</p> <p>This functionality is typically used with pumps, heater or fans to ensure that the on time of the duty and assist devices are evened out ensuring that the duty device does not wear out significantly before the assist device.</p> <p>Note. Output switching is only available on <i>Loop 1</i> if the <i>Loop 1 Output Type</i> is configured as <i>Split Output</i> and both outputs are configured as analog outputs.</p>
Switch Enable	Enable / Disable the <i>Output</i> switching feature.
Switch Source	Select the digital signal that will act as the switch source for the <i>Output</i> switching feature. The output is switched on the rising edge.



7.5 Process Alarm

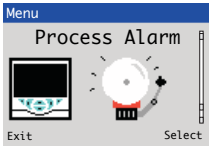

Used to configure up to 8 independent process alarms.

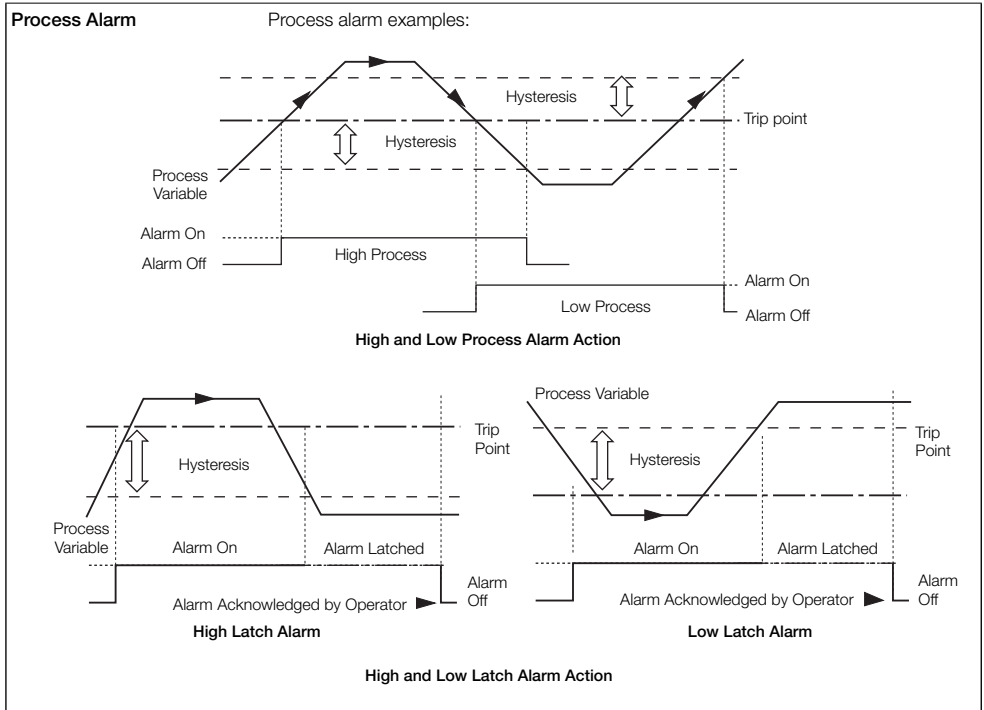

...Process Alarm

Alarm 1 (8)	
Type	Alarm types comprise: <i>High Process, Low Process, High Latch, Low Latch.</i> (Deviation alarms are configured using a high or low process alarm and selecting <i>Deviation</i> as the source.)
Tag	The alarm <i>Tag</i> is displayed as a diagnostic message and appears in the <i>Diagnostic Status Bar</i> and the Diagnostic view in the <i>Operator Level</i> .
Source	The analog source – see Appendix A, page 104 for description of sources.
Trip	Alarm trip level in engineering units.
Hysteresis	Hysteresis trip level in engineering units. Activated at the alarm trip level but deactivated only when the process variable has moved into the safe region by an amount equal to the hysteresis value – see <i>Process Alarm</i> examples on page 58.
Time Hysteresis	If an alarm trip value is exceeded, the alarm does not become active until the <i>Time Hysteresis</i> value has expired. If the signal goes out of the alarm condition before the <i>Time Hysteresis</i> has expired, the hysteresis timer is reset.
Display Enable	Enables an alarm to be used for control purposes without it appearing as an active alarm state in the <i>Operator level</i> or <i>Diagnostic</i> views.
Acknowledge Source	The source required to acknowledge all active alarms. Acknowledge occurs on rising edge of the digital signal – see Appendix A, page 104 for description of sources.
Enable Source	The source required to enable alarms. If <i>the source is None</i> , alarms are always enabled – see Appendix A, page 104 for description of sources.



7.6 Profile

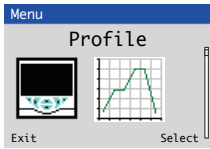

The *Ramp / Soak Profile* facility is a setpoint profile generator which can be used with any type of control process for more complex setpoint control. A *Profile* program is made up of *Ramps* (the setpoint is increased / decreased at a linear rate until it reaches the desired value) and *Soaks* (the setpoint is maintained at fixed value for a set time duration).

Note. Profile functionality is not enabled if functionality level = *Basic*, or Dual loop application templates are enabled.

Introduction to Ramp / Soak Profile Control

- 30 programs (1 if functionality = *Standard*)
- 140 programmable segments (10 if functionality = *Standard*)
- 5 segment types – *Soak*, *Ramp Rate*, *Ramp time*, *Wait**, *Step*, *End*
- Programmable time units – hours or minutes
- Programmable Ramps – can be programmed as rates or time units
- Program Repeat – 0 to 10 times or continuously
- Program holdback hysteresis

Separate settings for ramp and soak segments. Can be applied above, below or above and below the setpoint.

- 8 Segment Events* – enabled / disabled per segment
- PV Event* – Event may be generated if PV is above/below configured trip value or deviates from configured trip value
- Timed Event* – Event may be generated during a segment for a defined time period
- User Value* – configure an analog value that is output for the duration of each segment
- Programmable start conditions – Program, Local Setpoint, Current PV
- Retort function* – ensures safe operation under fault conditions, see Section 7.6.4, page 64.
- Recovery action – determines profile operation under power fail / PV fail conditions
- Fast Run mode – runs program 8 times normal speed for test/commissioning

*Enabled only if functionality = *Extended* / *Dual*.

7.6.1 Ramp Types

The profile set point can be configured to increment in one of two-way: for a fixed period of time or for a number of engineering units per hour.

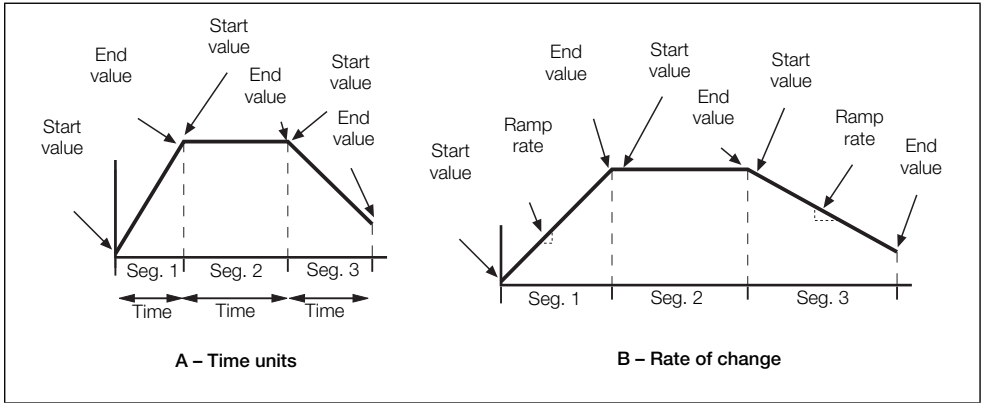

Fig. 7.1 Ramp Types

7.6.2 Guaranteed Ramp / Soak

If the process variable deviates from the set point by more than the hysteresis value, the program status is set to *HOLD* and Guaranteed ramp/soak is applied automatically.

Each program has two associated hysteresis values:

- **Ramp** – applied to ramping segments and
- **Soak** – applied to soak segments.

The hysteresis value can be set within the limits '0' to '9999' where a setting of '0' implies that no deviation from the set point value can be tolerated.

Hysteresis can be applied in one of four ways, with individual settings for each segment:

- **None** – hysteresis not applied, ramp/soak not guaranteed.
- **High** – hysteresis applied above set point ('HOLD' set if $PV > [SP + \text{Hysteresis}]$).
- **Low** – hysteresis applied below set point ('HOLD' set if $PV < [SP - \text{Hysteresis}]$).
- **High/Low** – hysteresis applied above and below set point (*HOLD* set if $PV > [SP + \text{Hysteresis}]$ or $PV < [SP - \text{Hysteresis}]$).

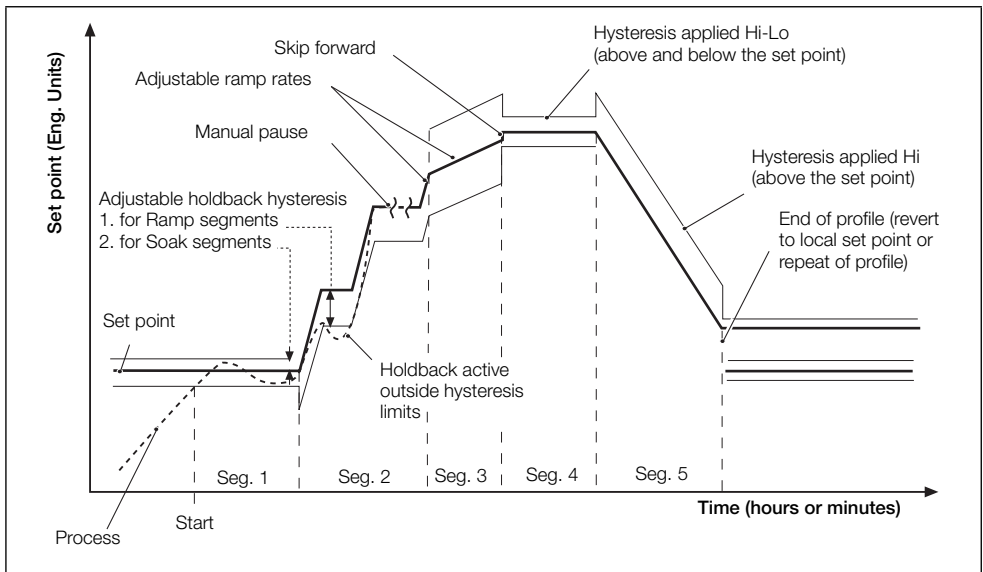

Fig. 7.2 Ramp Types

Note. Ramping segments can have a different hysteresis to soak segments.

7.6.3 Set Point Start Condition – Current PV

Selecting Current PV reduces the delay between the end of a program and the beginning of the next program. The process variable value is used as the program start point and the set point steps up to the process variable value. This has the effect of changing the overall segment time and maintains a constant ramp rate.

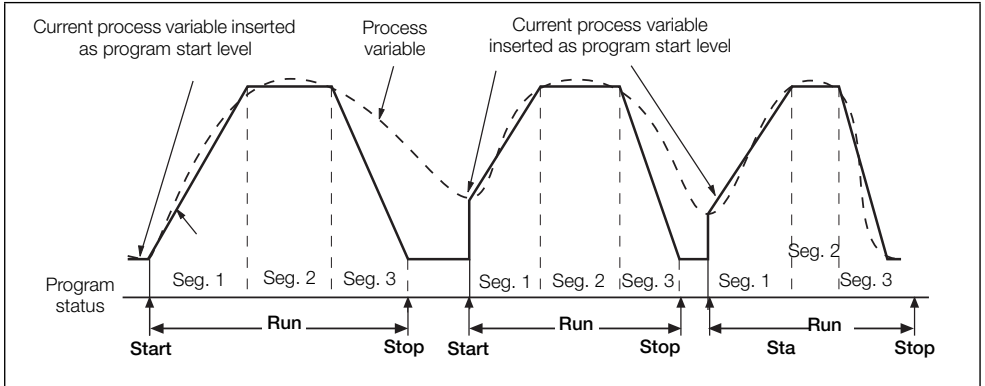

Fig. 7.3 Current PV

7.6.4 Retort Function

The Retort function ensures safe operation of retort vessels under fault conditions. If the heat source fails during a soak segment, the process variable will inevitably fall. When the process variable falls below the holdback hysteresis value the program is put on HOLD (as for normal operation). The set point then follows the process variable as it continues to fall (Retort Hold). The set point then follows the process variable as it continues to fall (Retort Hold).

- Set Point = Process Variable + Hysteresis value

Upon recovery of the heat source, the process is controlled at the new set point value. When the process variable reaches the set point it is then ramped back to the initial soak value at the rate of the previous ramp (Retort Ramp). When the soak level is reached the program is released from its hold state and the segment is either completed or repeated from the beginning, depending on the retort mode selected.

The retort mode is selected in the *Ramp / Soak Profile* page.

Note. For the retort function to operate, either LO or HI-LO hysteresis must be applied to the soak segments.

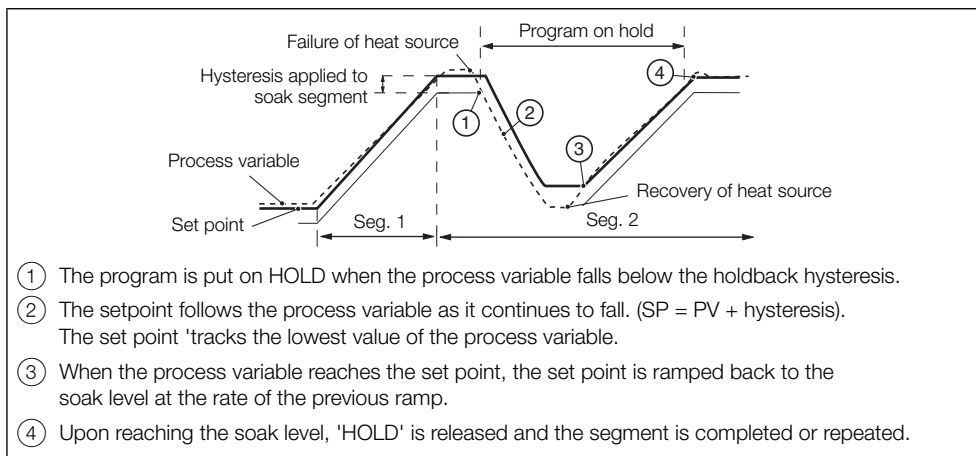

Fig. 7.4 Retort Function

7.6.5 Segment Events

8 General purpose segment events are provided that can be activated by each segment as it starts. The events remain active for the duration of the segment.

Events can be assigned to relays, digital outputs, logic equations (etc.) in the same way as other digital signals.

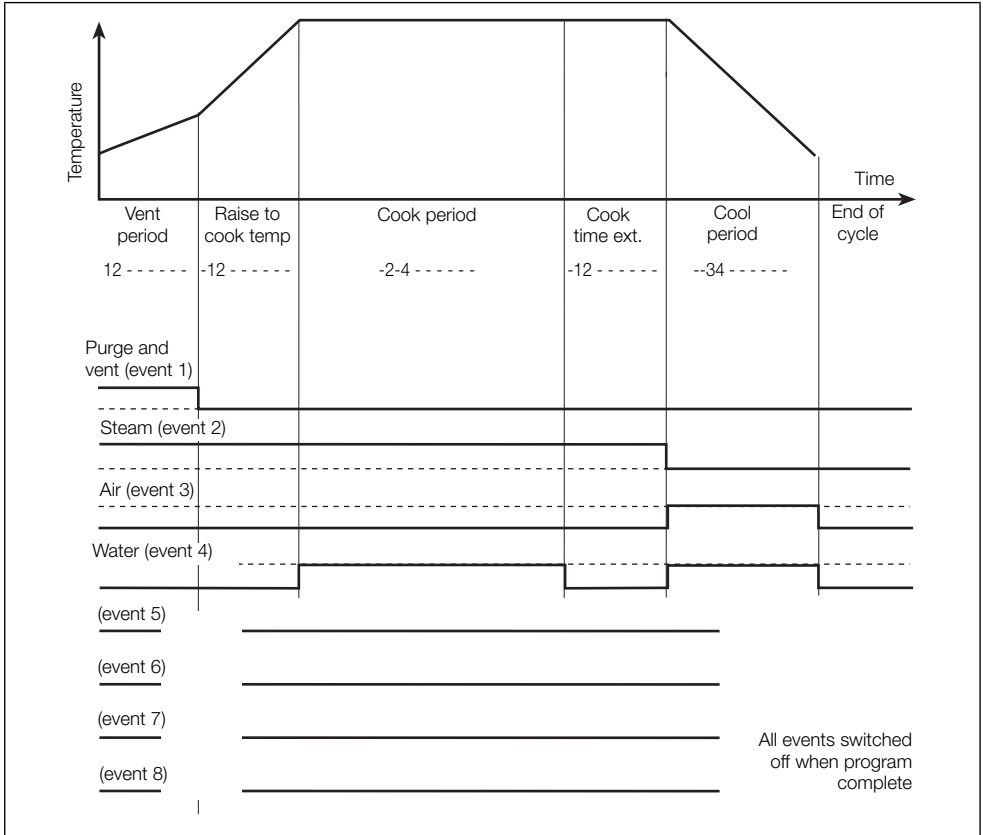





Fig. 7.5 Time Events (Example with 4 Events)

7.6.6 Profile Parameters

Common Settings ■	
SPT Start Condition	A start condition shall be specified for each control loop that determines the initial start setpoint of the program.
Program Setpoint	The program will start at the setpoint configured by <i>Setpoint Start</i> parameter.
Local Setpoint	The program will start from the current local setpoint value.
Current PV	The program will start from the current process variable value. Applies only if the first segment is a ramp.
Ramp Control	
Ramp Type	Selects the Ramp Type required. The ramp type selected applies to all programs / segments. The profile set point can be configured to increment in one of two way: for a fixed period of time or for a number of engineering units per hour.
Rate	Defined as rate / time unit (hr, min, sec).
Time	Defined in hr:min:sec.
Ramp Units	Selects the ramp rate time units required (Units/min, Units/hr, Units/sec).
Program Control	
Run	Selects the digital source used to start the program. The program is started on the rising edge.
	
Hold	Selects the digital source used to put the program into 'Operator hold' mode. Hold mode is entered on the rising edge.
	
Reset	Selects the digital source used to reset a running program. The program is reset on a rising edge. If the program was running, it will run from the start. If the program was held it will remain held at the start point.
	

...Profile Parameters / ...Common Settings ■

Run / Hold	Selects the digital source used to start and hold the program. The program runs when the input is high and holds when the input is low.
Stop	Selects the digital source used to stop the program. The program is stopped on the rising edge.
Skip Segment	Selects the digital source used to skip to the next segment. The segment is skipped on the rising edge.
Repeat Segment	Selects the digital source used to repeat the current segment. The segment is repeated on the rising edge.
Wait Event 1	Selects the digital source used to activate <i>Wait Event 1</i> and <i>Wait Event 2</i> . The program will enter a wait state when the state of the inputs corresponds with the condition enabled in the current segment.
Wait Event 2	
	Note: Displayed only if <i>Wait Events</i> are enabled.
Next Program	Selects the digital source used to activate the <i>Next Program</i> .
Previous Program	Selects the digital source used to activate the <i>Previous Program</i> .
Recovery	
Action	Selects the profile restart action when power is restored after a failure or the PV is restored after a failure and the <i>Recovery Period (Time – see below)</i> has expired.
<i>Continue</i>	The program resumes from the point at which failure occurred and is placed in <i>Operator Hold</i> mode.
<i>Repeat</i>	The program resumes from the start of the current segment and is placed in <i>Operator Hold</i> mode.
<i>Reset</i>	The program resumes from the start of the current program and is placed in <i>Operator Hold</i> mode.
<i>Advance</i>	The program resumes at the point in the program that would have been reached if no power failure had occurred in <i>Run</i> mode.
	Note: If a zero time period is selected the program will always with the chosen option.
Time	Set the recovery time period used to determine the recovery action. The time is configurable in HH:MM:SS.

...Profile Parameters / ...Common Settings ■

Segment Options	
Guaranteed Ramp/Soak	Enables the <i>Guaranteed Ramp/Soak (Holdback)</i> function. When enabled (<i>On</i>), the relevant configuration frames are displayed in <i>Program / Segment</i> menus to allow the <i>Guaranteed Ramp/Soak</i> function to be configured.
Events 1 to 8	Enables the <i>Segment Event</i> function. When enabled (<i>On</i>), the relevant configuration frame is displayed for each segment to allow the <i>Segment Events</i> to be configured.
PV Event	Enables the <i>PV Event</i> function. When enabled (<i>On</i>), the relevant configuration frames are displayed in the <i>Program / Segment</i> menus to allow the <i>PV Event</i> to be configured.
Timed Event	Enables the <i>Timed Event</i> function. When enabled (<i>On</i>), the relevant configuration frames are displayed for each segment to allow the <i>Timed Event</i> to be configured.
User Value	Enables the <i>User Value</i> function. When enabled (<i>On</i>), the relevant frames are displayed to allow the <i>User Value</i> function to be configured.
Retort Function	Enables the <i>Retort</i> function. When enabled (<i>On</i>), the relevant frames are displayed to configure the <i>Retort</i> function.
<i>Continue</i>	Continues to the next segment.
<i>Repeat Segment</i>	Repeats the current segment.
PV Event Trip	The <i>PV Event Trip</i> value used to determine the <i>PV Event</i> status for each segment. The value is set in <i>PV</i> engineering units. Note. Available only if the <i>PV Event</i> functionality is enabled in the <i>Segment Options</i> menu.
User Value Limits	
Default Value	The default value that the <i>User Value</i> will be set to when a program is not running. Note. <i>User Value</i> menu only available if the <i>User Value</i> functionality has been enabled in the <i>Segment Options</i> menu.
Low Limit	The <i>Low Limit</i> parameter is used to set the minimum <i>User Value</i> value that may be entered for each segment.
High Limit	The <i>High Limit</i> parameter is used to set the maximum <i>User Value</i> value that may be entered for each segment.
Fast Run Mode	This frame enables a mode that allows the profile program to be run 8 times faster than the programmed times. In this mode guaranteed <i>Ramp / Soak</i> settings are ignored but wait conditions are not overridden.

...Profile Parameters ■

Enter Program ■	
<u>Program No.</u>	Select the program to be configured (1 – 30).
<u>Name</u>	Enter the <i>Program Name</i> (up to 16 characters) to be used to identify the running program in the <i>Operator Page</i> display.
<u>Repeat Count</u>	Enter the number of times the program is to be repeated.
None	The program will not be repeated (it will run once).
1 ... 10	The program repeats as defined, for example, if '1' is selected the program runs twice.
Continuous	The program runs continuously until stopped by the operator.
<u>Setpoint Start/End</u>	
<u>Start</u>	The start setpoint value for the first segment of the program. Note. Available only if the <i>SPT Start Condition</i> parameter is set to <i>Program Setpoint</i> .
<u>End</u>	Defines the end condition of the program:
<u>Local Setpoint</u>	The program will enter the <i>Stop</i> state and switch to the currently selected <i>Local Setpoint</i> .
<u>Hold Setpoint</u>	The program remains active and in control at the setpoint defined by the last segment. It remains active until stopped, at which point the <i>Control Setpoint</i> switches to the current <i>Local Setpoint</i> .
<u>Jump Program</u>	At the end of the program, the profiler jumps to the start of another configured program.
<u>Jump To Program</u>	Define the next program that the profiler will jump to on completion of the current program. Note. Available only if <i>Setpoint End</i> condition is set to <i>Jump Program</i> .
<u>Holdback Hysteresis</u>	Hysteresis values are used to hold the program when the process value deviates from the setpoint by more than the hysteresis value as defined by the <i>Guaranteed Ramp</i> option for each segment. Note. Available only if <i>Guaranteed Ramp</i> is enabled.
<u>Soak</u>	Set the hysteresis value applied to <i>Soak</i> segments.
<u>Ramp</u>	Set the hysteresis value applied to <i>Ramp</i> segments.

...Profile Parameters / ...Enter Program ■

Enter Segments	
Segment No.	Enter the segment number to be configured.
Type	Select the segment type as described below:
<i>Soak</i>	Maintains the setpoint at a constant value for the duration of the segment. A soak segment requires the entry of the desired duration in hh:mm:ss. If the soak segment is the 1st segment in a program the setpoint value will be set as defined by the <i>SPT Start Condition</i> parameter. For other segments, the setpoint value will be derived from the end setpoint value of the previous segment.
<i>Ramp Rate</i>	Increases or decreases the setpoint at a linear rate until the desired value is reached. A <i>Ramp Rate</i> segment requires the user to enter the desired end setpoint and the desired ramp rate. The ramp rate is entered in engineering units per time period. The time period is defined by the <i>Ramp Rate Units</i> parameter.
<i>Ramp Time</i>	Increases or decreases the setpoint at a linear rate until the desired value is reached. A <i>Ramp Time</i> segment requires the user to enter the desired end setpoint and the desired ramp duration in hh:mm:ss.
<i>Step</i>	Changes the setpoint value from the end value to of the previous segment to a new value. A <i>Step</i> segment requires the entry of the <i>Step</i> setpoint value.
<i>Wait</i>	Delays the program until a condition has been met as defined by either or both of the <i>Wait Event</i> digital signals. Note. <i>Ramp Rate</i> or <i>Ramp Time</i> will be displayed according to the setting of the <i>Ramp Type</i> parameter in <i>Common Settings</i> (see page 66).
<i>End</i>	Ends the program.
Period	Select the soak or ramp period of the segment in hhh:mm:ss. Note. Only displayed if <i>Segment Type</i> is configured as <i>Soak</i> or <i>Ramp</i> time.
Setpoint	Select the required end setpoint value for the segment in engineering units. Note. Only displayed if the <i>Segment Type</i> is configured as <i>Ramp Rate</i> or <i>Ramp Time</i> .
Ramp Rate	Select the required <i>Ramp Rate</i> for the segment. Note. Only displayed if <i>Segment Type</i> is <i>Ramp Rate</i> .
Wait Events	Select the condition under which the <i>Wait</i> segment will delay the program. The segment will enter a wait condition when the <i>Wait Event</i> digital inputs match the segment wait condition as defined below.
<i>Event 1</i>	Waits on the event as defined by the <i>Wait Event 1</i> digital signal.
<i>Event 2</i>	Waits on the event as defined by the <i>Wait Event 2</i> digital signal.
<i>Event 1 OR 2</i>	Waits on the state of <i>Wait Event 1</i> OR <i>Wait Event 2</i> .
<i>Event 1 AND 2</i>	Waits on the state of <i>Wait Event 1</i> AND <i>Wait Event 2</i> . Note. Displayed only if <i>Segment Type</i> is <i>Wait</i> .

...Profile Parameters / ...Enter Program ■

Guaranteed Ramp Guaranteed Soak	Select how the Guaranteed Ramp/Soak feature will be applied to the segment.
None	Guaranteed Ramp/Soak is disabled for the segment.
High	Guaranteed Ramp/Soak is applied above the setpoint.
Low	Guaranteed Ramp/soak applied below the setpoint.
High/Low	Guaranteed Ramp/Soak is applied above and below the setpoint. Note. Displayed only if <i>Guaranteed Ramp/Soak</i> is enabled in the <i>Segment Options</i> menu – see page 62 for detailed explanation.
Event 1 to 8	Select the state of each of the 8 general purpose events for the duration of the segment. Note. Displayed only if <i>Event 1 to 8</i> is enabled in the <i>Segment Options</i> menu.
PV Event	Select the condition under which the <i>PV Event</i> will become active for the duration of the segment.
None	The <i>PV Event</i> is disabled for the segment.
High Limit	The <i>PV Event</i> is enabled when the <i>Process Variable</i> goes above the <i>PV Event Trip</i> value.
Low Limit	The <i>PV Event</i> is enabled when the <i>Process Variable</i> goes below the <i>PV Event Trip</i> value.
Dev High	The <i>PV Event</i> is enabled when the <i>Process Variable</i> goes above the <i>Setpoint</i> by more than the <i>PV Event Trip</i> value.
Dev Low	The <i>PV Event</i> is enabled when the <i>Process Variable</i> goes below the <i>Setpoint</i> by more than the <i>PV Event Trip</i> value.
Dev High/Low	The <i>PV Event</i> is enabled when the <i>Process Variable</i> goes above or below the <i>Setpoint</i> by more than the <i>PV Event Trip</i> value. Note. Displayed only if <i>PV Event</i> is enabled in the <i>Segment Options</i> menu.
Timed Event Offset	The offset time in hh:mm:ss from the start of the segment at which the <i>Timed Event</i> will be enabled. Note. Displayed only if <i>Timed Event</i> is enabled in the <i>Segment Options</i> menu.
Timed Event Length	The duration of the <i>Timed Event</i> signal in hh:mm:ss. Note. Displayed only if <i>Timed Event</i> is enabled in the <i>Segment Options</i> menu.
User Value	Select the <i>User Value</i> required for the segment within the range defined by the <i>High/Low</i> limits configured in the <i>User Value Limits</i> menu. Note. Displayed only if <i>User Value</i> is enabled in the <i>Segment Options</i> menu.

7.7 Totalizer

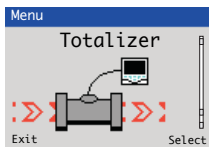

Two 9-digit totalizers are provided. These can be configured independently to totalize any analog or digital signal. Four modes of operation are provided.

Where possible, the count rate is calculated automatically according to source units, totalizer units and engineering range.

Totalizer 1 (2) ▲

Mode

- Off** Totalizer disabled.
- Analog** Totalization of any analog signal.
- Digital** Counting of low / high transitions of any digital signal (for example, digital input or alarm) minimum pulse duration >125 ms.
- Frequency** Totalization of a frequency input on Analog input 1.
- Pulse** Totalization of a pulse input on Analog input 1.

Source The input to be totalized. The inputs available for selection are dependent on the selected *Mode*. Not displayed for frequency and pulse inputs – see Appendix A, page 104 for description of sources.

Count Direction

- Up** Totalizer value increases with time.
- Down** Totalizer value decreases with time.

Units (Totalizer) units are used along with the source's units and engineering range to calculate the count rate automatically (where possible). Where the units or mode required do not allow this, the count rate must be calculated manually – see Section 7.7.1, page 74.

Count Rate In *Analog* mode, this represents the counts (in volume units) / second when the source is at its engineering high value.
 In *Digital*, *Frequency* and *Pulse* mode, this represents the number of totalizer (volume) units / pulse.

Cutoff The lowest input value (in engineering units) at which the totalizer stops counting.

Stop Go Source The source required to stop and start the totalizer. Selection is made on the rising edge.

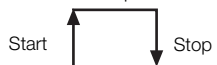

...Totalizer ■

Total DP's	Selects the number of decimal places displayed on the totalizer value.
Preset Count	The value the totalizer counts from and the value applied when the totalizer is reset.
Predet Count	The value at which the totalizer stops or wraps.
Intermed'te Count	The value at which the intermediate count digital signal is activated. This can be used as an alarm threshold to indicate when the <i>Predet Count</i> value is about to be reached.
Wrap Enable	If set to <i>On</i> , the total is reset automatically to the <i>Preset Count</i> value once the <i>Predet Count</i> value is reached. The wrap <i>Digital</i> signal is activated for 1 second. If set to <i>Off</i> the count stops when the <i>Predet Count</i> value is reached. The wrap <i>Digital</i> signal is activated until the totalizer is reset.
Reset Source	The source required to reset the totalizer value. Selection is made on the rising edge. 
Reset Days	Selects the day or days to reset the totalizer.
Reset Hour	Selects the hour to reset the totalizer (the totalizer is always reset exactly on the hour).

7.7.1 Calculating the Totalizer Count Rate Manually

Analog Mode

$$\text{Count Rate} = \frac{\text{Eng Hi (of source)} \times \text{volume unit conversion}}{\text{time unit conversion}}$$

Example:

Eng Hi = 2500 l/m. Totalizer required to increment in m³.

Volume unit conversion: 1 l = 0.001 m³.

Source time units = minutes, count rate units = seconds.

Time unit conversion: 1 min = 60 s.

$$\text{Count Rate} = \frac{2500 \times 0.001}{60} = 0.04167 \text{ m}^3/\text{s}$$

If the input source is at a fixed rate of 2500 l/min, the totalizer increments at 0.04167 m³/s.

If the input source is reduced to a fixed rate of 1250 l/min, the totalizer increments at:

$$\frac{1250}{2500} \times 0.04167 = 0.0208 \text{ m}^3/\text{s}.$$

Digital Mode

The count rate setting determines the scaling of the digital input pulses.

For example, with a Count Rate = 100 totalizer units / pulse, 5 digital input pulses increment the totalizer from 0 to 500 in 100 unit steps:

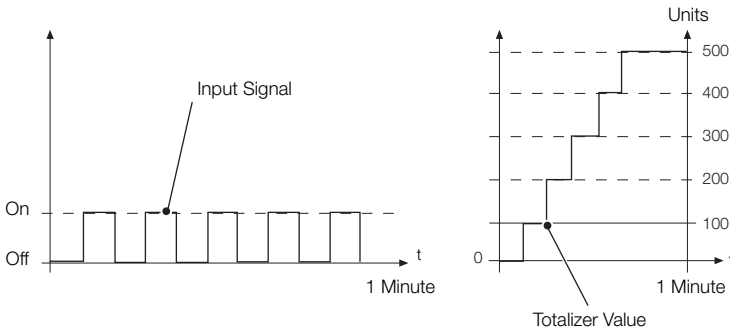

Frequency Mode

$$\text{Count Rate} = \frac{\text{Eng Hi (of source)} \times \text{volume unit conversion} \times \text{pulse duration}}{\text{time unit conversion}}$$

Example:

Eng Hi = 6000 l/m. Frequency input fullscale (Electrical High) = 500 Hz,

Totalizer required to increment in m³.

Volume unit conversion: 1 l = 0.001 m³.

Source time units = minutes, count rate units = seconds.

Time unit conversion: 1 min = 60 s

$$\text{Pulse Duration} = \frac{1}{\text{Analog input 1 Electrical High (Hz)}}$$

$$\text{Count Rate} = \frac{6000 \times 0.001 \times 0.002}{60} = 0.0002 \text{ m}^3/\text{s}$$

if the input source is at a fixed rate of 6000 l/min (500 Hz) the totalizer increments at 0.0002 m³/s.

If the input source is reduced to a fixed rate of 3000 l/min (250 Hz), the totalizer increments at:

$$\frac{3000}{6000} \times 0.0002 = 0.0001 \text{ m}^3.$$

Pulse Mode

$$\text{Count Rate} = \frac{\text{Volume unit conversion}}{\text{Pulse / Unit}}$$

Example:

Pulse / Unit = 50, Pulse Units = l, Totalizer required to increment in m³.

Volume unit conversion: 1 l = 0.001 m³.

$$\text{Count Rate} = \frac{0.001}{50} = 0.00002 \text{ m}^3/\text{pulse}$$

7.8 Functions

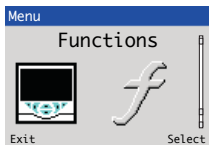

Contains parameters for setting up the math block(s), logic equations and timer functions within the controller.

Logic Equations ■

Up to 8 logic equations can be configured. Each equation can combine a maximum of 8 operands (digital signals) with 7 operators.

The elements of each equation are calculated sequentially. Operand 1, Operator 1 and Operand 2 are evaluated first and the result is combined with Operator 2 and Operand 3. This result is then combined with the next operator and operand and so on to the end of the equation.

Setting an operator to *END* terminates the equation.

Notes. 2 Logic equations are required to perform an exclusive *OR* of 3 inputs.

As part of the cascade template, logic equation 1 is preconfigured. Changes to this equation will result in the cascade template not functioning correctly.

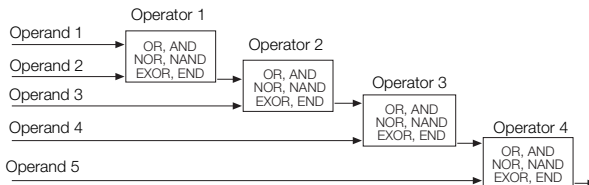

Key:

OR	Output is 1 if either or both inputs are 1; output is 0 if both inputs are 0
AND	Output is 1 if both inputs are 1; output is 0 if either input is 0
NOR	Output is 0 if either or both inputs are 1; output is 1 if both inputs are 0
NAND	Output is 0 if both inputs are 1; output is 1 if either input is 0
EXOR	Output is 0 if both inputs are 0 or both inputs are 1; output is 1 if one input is 1 and the other is 0
END	Terminates the equation

Note. If any of the operand sources are invalid (for example, an alarm that is not configured), the logic equation output state is zero and invalid.

Equation Number	Selects the logic equation (1 to 8) to be configured.
Operand 1 (8)	See Appendix A, page 104 for description of sources.
Invert 1 (8)	Logically inverts (applies <i>NOT</i> function to) the digital signal. For example, if the digital signal assigned to the operand has a state of '1' it is inverted to a state of '0' before being applied to the equation.
Operator1 (7)	Selects the operator type (<i>OR</i> , <i>AND</i> , <i>NOR</i> , <i>NAND</i> , <i>EXOR</i>). Select <i>END</i> if no more elements are required.

...Functions ■

Math Blocks ■

Up to 8 math blocks can be configured. Each block can be configured as one of 6 different types (see *Block Type* below). The resulting analog value can be used as a source for other function blocks, for example, *Process Variable* in the *Custom Config* parameter – see page 36.

Math Block Number The math block number (1 to 8).

Block Type Selects the type of math block required.

Equation (See page 78 for *Equation* setup.)

Enables an equation with up to 4 operands and 3 operators to be created. The operands can be assigned to any analog or digital signal (see page 104). Digital signals have a value of either '0' or '1'. With the exception of the Median operator, the equation is processed in a strict left to right order, with no operator precedence.

The result of a math block can be used as the operand in another math block, enabling more complex math equations to be constructed. The math blocks are processed in ascending order; *Math Block 1* is processed first, then *Math Block 2*, then 3 to 8.

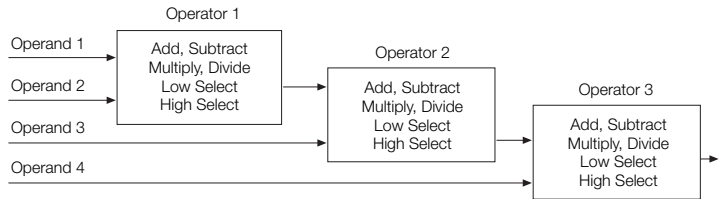

Real Time Average (See page 78 for *Real Time Average* setup.)

Calculates the average value of a parameter over a user-configurable duration. The output of the math block is updated at the end of the set duration only. A reset signal can be configured to restart the calculation of the average value.

The average value is stored in case of power failure. If the duration of the power failure is longer than the *Average Duration* (see page 78), the math block output value is set to zero.

Max Hold / Min Hold (See page 78 for *Max Hold / Min Hold* setup.)

The math block output represents the highest / lowest value of the signal since it was reset.

Multiplexer (See page 79 for *Multiplexer* setup.)

Enables 1 of 2 analog signals or constant values to be selected using a digital signal.

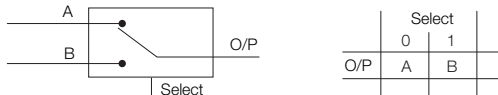

Square Root (See page 79 for *Square Root* setup.)

Calculates the square root of the selected sources value. If the input is less than 0, the output is set to zero and the math block output state set to invalid.

...Functions / ...Math Blocks ■

Equation Setup

Source 1 (2)	The source of the first operand in the equation (any analog or digital signal or user-defined constant).
Source 1 (2) Constant	Sets the constant value to be used. Note. Applicable only if <i>Source 1</i> is assigned to one of the constants.
Operator 1 (3)	
End	Terminates the equation.
Add	} Standard arithmetic functions.
Subtract	
Multiply	
Divide	
Low Select	
High Select	Result is the higher of the 2 operands.
Median	If <i>Median</i> operators are used the median value calculated is dependent on the number of operands: <ul style="list-style-type: none"> ■ The median value of 2 operands is their mean value. ■ The median value of 3 operands is the value of the middle operand when the operands are sorted in ascending order. ■ The median value of 4 operands is the mean value of the 2nd and 3rd operands when the 4 operands are sorted in ascending order.

Real Time Average Setup

Source 1	Selects the source for real time average value calculation – see Appendix A, page 104 for description of sources.
Reset Source	Selects the digital source required to reset the internal accumulative value and timer. This does not change the immediate output of the math block but restarts the calculation of the next average value.
Average Duration	Sets the time duration the average is to be calculated over. The output value of the math block is updated at this rate.

Max Hold / Min Hold Setup

Source 1	Selects the source for maximum / minimum value calculation – see Appendix A, page 104 for description of sources.
Reset Source	Select the digital signal to be used to reset the maximum or minimum value.

...Functions / ...Math Blocks ■

Multiplexer Setup

Source 1	Selects the source for the first input into the multiplexer.
Source 1 Constant	Sets the constant value to be used. Note. Applicable only if <i>Source 1</i> is assigned to one of the constants.
Source 2	Select the source for the second input into the multiplexer.
Source 2 Constant	Sets the constant value to be used. Note. Applicable only if <i>Source 1</i> is assigned to one of the constants.
Mux Selector	Select the digital signal to be used to switch between the 2 multiplexer inputs. '0' selects first input (<i>Mux A Src</i>); '1' selects second input (<i>Mux B Src</i>).

Square Root Setup

Source 1	Selects the source of the parameter that requires square root to be applied.
----------	--

Setup for **All Math Block Types**

Eng. Dps	Selects the number of decimal places (resolution) displayed for the math block result.
Eng. Low Eng. High	Selects the engineering range low / high value for display purposes and for calculation of the proportional band. If the math block result exceeds the <i>Eng High</i> or <i>Eng Low</i> value by more than 10 %, a math block fail state is set and its output is determined by the <i>Fault Action</i> – see below.
Eng Units	The selected units are displayed in the operator pages – see Appendix C, page 108 for description of engineering units.
Fault Action	The value returned when the math block fails can be configured.
None	Failed calculated value is used as math block output.
Automatic	If the failed calculated output value is below zero the output is driven to the minimum value. If the failed calculated output value is above zero the output is driven to the maximum value.
Upscale	If the math block fails, the output is driven to the maximum value.
Downscale	If the math block fails, the output is driven to the minimum value.

...Functions ■

<p>Linearizer 1 (2) ■</p> <hr/> <p>Source 1 (2)</p> <p>Lin 1 (2) Breakpoints</p> <p> <i>Breakpoint</i></p> <p> <i>X</i></p> <p> <i>Y</i></p>	<p>A 20-breakpoint (custom) linearizer. Custom linearizers are applied by:</p> <ol style="list-style-type: none"> 1. Selecting an analog source as the input to the linearizer. 2. Selecting the custom linearizer output as the source to be displayed. <p>The engineering range and units of the input source are assigned to the custom linearizer output.</p> <p>Selects the input source to be linearized – see Appendix A, page 104 for description of sources.</p> <p>Selects the breakpoint to be configured.</p> <p><i>X</i> is input to the linearizer expressed as a % of the electrical range.</p> <p><i>Y</i> is output expressed as a % of the engineering range.</p> <p>Once configured, a custom linearizer must be soft-wired to an input or output using the custom template feature – see Section 7.1, page 34.</p>	
<p>Delay Timer 1 (2)</p> <hr/> <p>Source 1 (2)</p> <p>Delay Time</p> <p>On Time</p>	<p>2 Delay timers are provided. The delay timer is triggered by the rising edge of its assigned source. An internal timer is started and, when the timer reaches the set <i>Delay Time</i>, its output goes high for the <i>On Time</i> that is configured. After the delay time is triggered it ignores any further transitions of the source input until the end of this delay timer cycle (until the end of the <i>On Time</i>).</p> <p>The source signal used to trigger the delay timer. Trigger occurs on rising edge of the signal – see Appendix A, page 104 for description of sources.</p> <p>The delay (in seconds) between the trigger received and the output of the delay timer going high.</p> <p>The length of time in seconds the delay timer output is held in the high state.</p>	

...Functions ■

Real Time Alarms ■	2 Independent real-time alarms can be configured to be activated on particular days and times for a set duration.
Real Time Alarm 1 (2)	Sets the days the alarm is activated, the alarm duration, alarm display enable in the diagnostics window and enables a (status bar) tag to be created for the alarm.
<i>Monday (to Sunday)</i>	
<i>Month enable</i>	When enabled (<i>On</i>), activates the alarm on the 1 st day of each month.
<i>Every hour</i>	When enabled (<i>On</i>), activates the alarm every hour.
<i>On hour</i>	Sets the hour the alarm is activated – not applicable if <i>Every Hour</i> is set to <i>On</i> .
<i>On minute</i>	Set the minutes past the hour the alarm is activated.
<i>Duration</i>	Set the duration the alarm is active.
<i>Display enable</i>	If disabled (<i>Off</i>), the alarm state does not appear in the operator level diagnostics window or the alarm log.
<i>Tag</i>	A 16-character alphanumeric tag displayed as a diagnostic message that appears in the <i>Diagnostic Status Bar</i> and in the <i>Operator Level, Diagnostic View</i> – see page 23.
Bank Control ■	Bank control functionality enables a bank of output devices such as pumps, heaters or fans to be switched <i>On</i> and <i>Off</i> under a duty / assist strategy. If required, one of two different wear levelling schedules can be selected, <i>Rotate</i> or <i>FIFO (First In First Out)</i> . Up to 6 stages may be configured for bank control, each of which can be assigned to a relay or digital output. Each stage has an associated <i>On</i> trip value, <i>Off</i> trip value and initial <i>Output</i> . All stages included in a wear levelling schedule must use the same schedule type (<i>Rotate</i> or <i>FIFO</i>). The example (overleaf) illustrates how the two modes operate to achieve wear levelling of 3 pumps in a duty / assist strategy.

...Functions / ...Bank Control ■

...Bank Control ■

Using *First In First Out (FIFO)* and *Rotate* modes on a 3 pump system

First In First Out (FIFO)

	Level	P1	P2	P3		Level	P1	P2	P3
Seq. 1	1.3 m	x	x	x	Seq. 6	2.2 m	x	x	✓
Seq. 2	2.2 m	✓	x	x	Seq. 7	0.8 m	x	x	x
Seq. 3	3.6 m	✓	✓	x	Seq. 8	1.8 m	✓	x	x
Seq. 4	4.3 m	✓	✓	✓	Seq. 9	0.8 m	x	x	x
Seq. 5	2.8 m	x	✓	✓	Seq. 10	1.8 m	x	✓	x

Rotate Pump Cycling

	Level	P1	P2	P3		Level	P1	P2	P3
Seq. 1	1.3 m	x	x	x	Seq. 6	2.2 m	✓	x	x
Seq. 2	2.2 m	✓	x	x	Seq. 7	0.8 m	x	x	x
Seq. 3	3.6 m	✓	✓	x	Seq. 8	1.8 m	x	✓	x
Seq. 4	4.3 m	✓	✓	✓	Seq. 9	0.8 m	x	x	x
Seq. 5	2.8 m	✓	✓	x	Seq. 10	1.8 m	x	x	✓

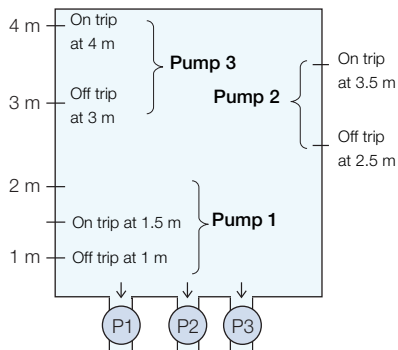

Bank Size

Select the number of stages (pumps) required for the application from 2 to 6 or *Off*. *Off* disables the *Bank Control* functionality.

Control Source

Select the analog signal to act as the control signal for the bank control. This is normally the Process Variable (PV) for most pump control applications.

Stage 1 (6)

Off Trip

Select the *Control Source* value (PV) at which the output (pump) is turned off.

On Trip

Select the *Control Source* value (PV) at which the output (pump) is turned on.

Output

Select the initial output (relay or digital output) that the output is assigned to by default (for example, when *FIFO* or *Rotate* mode is not in operation).

Schedule

Select the wear levelling schedule required:

Off – the output is not controlled by the bank schedule.

The state of the output is controlled entirely by its associated trip points.

FIFO – the output is controlled according to the *FIFO* schedule mode.

Rotate – the output is controlled according to the *Rotate* schedule mode.

7.9 Communication

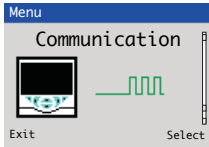

Used to setup communications parameters for the (optional) MODBUS / Ethernet / Profibus communication protocols – see separate User Guide (IM/CM/C-EN).

Note. Only one communications option can be fitted per controller.

7.10 Diagnostics

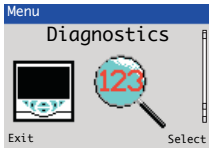

Used to view diagnostic and performance (historical) data – see Section 7.10.1 for description of diagnostic messages and recommended corrective action(s).

Diagnostic History Displays a log of the diagnostic messages generated by the controller. Each diagnostic condition has a classification code conforming to NAMUR NE107.

n = Number of instances of this diagnostic condition

Σ = Total time spent in this diagnostic condition

t_n = Time since the last instance of this diagnostic condition

Configuration

-- C178.025 --

In Configuration

n : 2

Σ : 00h 04m 07s

t_n : 01h 03 m 15s

M = Maintenance
 S = Out of Spec
 C = Check Function
 F = Failure

C 178.025
 Diagnostic priority
 Highest value = 250
 Internal Code

Source Analysis

Analog Sources	Enables the current value of any analog source to be viewed.
Analog Source	Selects the analog signal to be viewed – see Section 7.10.1, page 84.
View Value	Displays the value of the analog signal selected.
Digital Sources	Enables the current state of any digital source to be viewed.
Digital Source	Selects the digital signal to be viewed – see Appendix A.1 on page 104.
View State	Displays the state of the digital signal selected.
Invalid Sources	Select edit to display any invalid analog or digital sources that are used in the configuration.

Reasons for invalid sources include:

- Hardware not fitted
- Software not fitted
- Digital I/O configured as wrong type
- Alarms not configured
- Math, logic, timer or custom linearizer not configured

7.10.1 Diagnostic Messages

Icon	Number / Message	Possible Cause	Suggested Action
⊗	242.004 ADC 1 Failed	Temporary or permanent failure of analog to digital converter on the main I/O board.	Cycle power to device. If problem persists replace main I/O board, contact local service organization.
⊗	240.005 ADC 2 Failed	Temporary or permanent failure of analog to digital converter on the option board.	Cycle power to device. If problem persists replace option board, contact local service organization.
⊗	250.000 (248.001) PV 1 (2) Failed	Problem with Input assigned to Loop 1 (2) PV. Broken sensor leads, defective input source or input signal out of permitted range.	Check wiring. Check input source. Check if input signal is outside permitted limits.
⊗	246.002 (244.003) RSP 1 (2) Failed	Problem with Input assigned to Loop 1 (2) Remote Setpoint. Broken sensor leads, defective input source or input signal out of permitted range.	Check wiring. Check input source. Check if input signal is outside permitted limits.
⊗	222.014 (220.015) CJ 1 (2) Failed	Error in Cold junction measurement associated with AIN1 (AIN3). Wiring fault or defective sensor.	Check cold junction device is correctly fitted. Ensure I/P 2(4) is turned off. Replace CJ sensor.
⊗	226.012 (224.013) DV 1 (2) Failed	Problem with input assigned to Loop 1 (2) disturbance variable. Broken sensor leads, defective input source or input signal out of permitted range.	Check wiring. Check input source. Check if input signal is outside permitted limits.
⊗	230.010 (228.011) WV 1 (2) Failed	Problem with input assigned to Loop 1 (2) wild variable. Broken sensor leads, defective input source or input signal out of permitted range.	Check wiring. Check input source. Check if input signal is outside permitted limits.
⊗	234.008 (232.009) PFB 1 (2) Failed	Problem with input assigned to Loop 1 (2) position feedback. Broken sensor leads, defective input source or input signal out of permitted range.	Check wiring. Check input source. Check if input signal is outside permitted limits.
⊗	216.016 NV Error Proc Bd	Failure of non-volatile memory on processor / display board or permanent corruption of its data.	Check all configuration parameters and correct any errors. Acknowledge error. If problem persists contact local service organization.
⊗	214.017 NV Error Main Bd	Failure of non-volatile memory on main board or permanent corruption of its data.	CM30 and CM50 Check calibration of AIN1, AIN2 and AO1. CMF310 Check calibration of AO1 and AO2. CM30 / CM50 / CMF310 Recalibrate if necessary. Acknowledge error. If problem persists contact local service organization.

Table 7.1 Diagnostic Messages

Icon	Number / Message	Possible Cause	Suggested Action
⊗	212.018 NV Error Opt Bd 1	Failure of non-volatile memory on option board 1 or permanent corruption of its data.	CM50 only Check calibration of AO2, AIN 3 and AIN4. CMF310 Check calibration of AIN1 and AIN2. CM50 and CMF310 Recalibrate If necessary. Acknowledge error. If problem persists contact local service organization.
⊗	210.019 NV Error Opt Bd 2	Failure of non-volatile memory on option board 2 or permanent corruption of its data.	CM30 and CM50 Check calibration of AO2, AIN 3 and AIN4. CMF310 Check calibration of AIN3 and AIN4. CM30 / CM50 / CMF310 Recalibrate If necessary. Acknowledge error. If problem persists contact local service organization.
⊗	208.020 NV Error Comm Bd	Failure of non-volatile memory on communications board or permanent corruption of its data.	Acknowledge error. Check communications board is correctly identified by device. If problem persists contact local service organization.
⊗	206.021 NV Error SW Key 1	Failure of non-volatile memory on Software key 1 or permanent corruption of its data.	Acknowledge error. Check software key functionality is enabled. If problem persists contact local service organization.
⊗	204.022 NV Error SW Key 2	Failure of non-volatile memory on Software key 2 or permanent corruption of its data.	Acknowledge error. Check software key functionality is enabled. If problem persists contact local service organization.
⊗	202.023 NV Error SW Key 3	Failure of non-volatile memory on Software key 3 or permanent corruption of its data.	Acknowledge error. Check software key functionality is enabled. If problem persists contact local service organization.
⊗	Config Error	The configuration contains a source that is no longer present or valid.	Check invalid sources in diagnostics menu – see Section 7.10, page 83. Check configuration, check I/O required for configuration is present and correct any illegal use of the invalid signal by changing configuration or fitting additional option cards.
⚠	054.044 (052.045) Tune Lp1 (2) Fail	Autotune has failed to complete its sequence or has calculated values outside of its permitted range.	Check process response. Consider if Autotune dynamic setting should be changed. Ensure process is stable and repeat autotune. If problem persists tune the loop manually.
⚠	062.042 (058.043) Tune Lp1 (2) Noise	Autotune has failed due to excessive process or measurement noise.	Check input wiring. Ensure process is stable and repeat Autotune. If problem persists, tune the loop manually.

Table 7.1 Diagnostic Messages (Continued)









Icon	Number / Message	Possible Cause	Suggested Action
	070.040 (066.041) Tuner 1 (2) Abort	Autotune has been aborted by the user.	
	078.038 (074.039) Adaptive 1 (2) Warn	Parameters calculated by adaptive control have changed by more than the permitted amounts.	Check process for issues that may have caused a large change in its dynamics, for example, a blocked valve. Reset adaptive control. Perform a fresh autotune.
	086.036 (082.037) Oscillation 1 (2)	Abnormal oscillations in the control loop.	Check process. Perform new manual or Autotune.
	094.034 (090.035) Valve 1 (2) Sticking	Motorized valve travel time is significantly slower than configured time.	Check valve to identify reason for sticking. Check correct travel time is entered in configuration.
	168.026 (166.027) (164.028) Tuner 1 Phase 1..3	Autotune is in progress. See page 29 for details of each phase.	Autotune can be aborted if required by selecting <i>Manual</i> control mode.
	160.030 (158.031) 156.032 Tuner 2 Phase 1..3	Autotune is in progress. See page 29 for details of each phase.	Autotune can be aborted if required by selecting <i>Manual</i> control mode.
	162.029 (154.033) Tuner 1 (2) Pass	Autotune has completed successfully and calculated new control parameters.	Acknowledge diagnostic message.
	178.025 In Configuration	The device is currently in the configuration mode.	This is for use with remote access via digital communications.

Table 7.1 Diagnostic Messages (Continued)

7.11 Device Info



Used to display read-only factory-set parameters for the controller.

Instrument Type	The controller's model number (for example, CM30).
I/O Build	The input / output (I/O) configuration.
No. Analog Inputs	The number of analog inputs available.
No. Analog Outputs	The number of analog outputs available.
No. Relays	The number of relays available.
No. Digital I/O	The number of digital inputs / outputs available.
Functionality	The current functional setting of the controller (for example, <i>Dual Loop</i>).
Serial No.	The factory serial number.
Hardware Revision	The controller's hardware version number.
Software Revision	The controller's software version number.

8 Templates and Functionality

Notes.

- Input assignments can be changed in *Device Setup / Custom Config* – see page 36.
- Output assignments can be changed in *Input / Output* configuration – see page 42.

8.1 Basic Templates

8.1.1 Single Loop / Single Loop with Remote Setpoint

This template provides basic feedback control using three-term PID or On/Off control. The controller output is calculated from the difference between the process variable and the control setpoint. The control setpoint can be a fixed value entered by the user (Local setpoint) or an input from a remote source (remote setpoint).

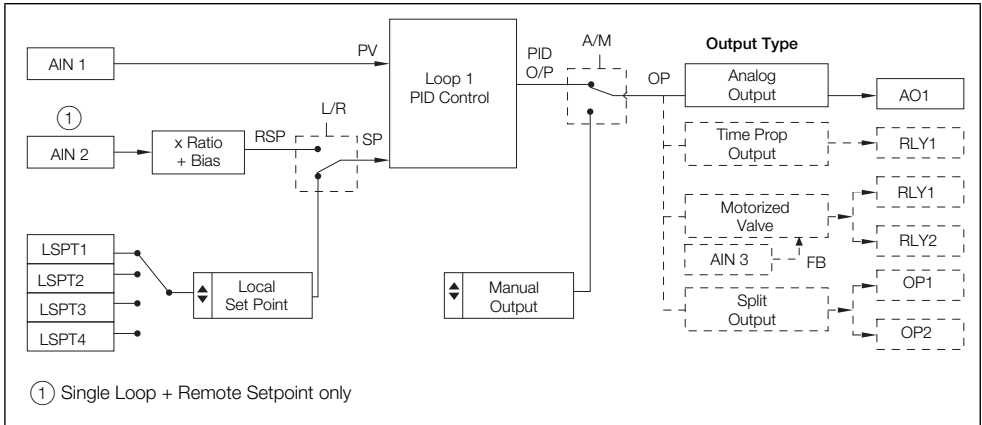

8.2 Standard Templates

8.2.1 Auto / Manual Station (Low Signal Selection / Digital Signal Selection)

This template configures the ControlMaster as a back up for a Master Controller (system). In normal operation the ControlMaster's current output follows the master controllers output value in Automatic mode. Upon detection of a fault in the Master system, which is identified by either a low signal value on the Master Output or via a digital Input signal, the ControlMaster selects Manual Mode with either the last valid Master Output value or a pre-configured fixed output value. Once the Master signal is restored or the digital input state returns to its normal state the ControlMaster switches back to Auto Mode and continues to follow the Master Controller output.

(See Fig. 8.1, page 91 for details of parallel connection).

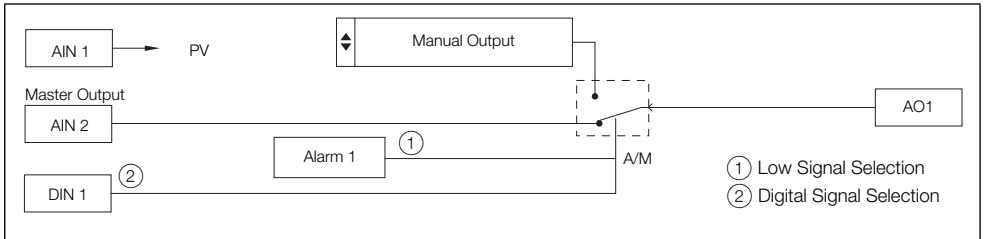

8.2.2 Analog Backup Station (Low Signal Selection / Digital Signal Selection)

This template provides a back up for a master controller (system). In normal operating mode, the ControlMaster operates in Remote Control Mode. In this mode the output of the ControlMaster follows the Master controller's output. If a fault is detected in the Master system, either by a low signal on the Master output or by a digital input, the ControlMaster switches into Local Control Mode and the process is controlled by the PID output of the ControlMaster.

The PID algorithm continuously tracks the Master Controller output value to ensure a bumpless transfer from remote to local operation. Once the Master Controller output is restored or the digital Input returns to its normal state the ControlMaster switches back to Remote Control Mode and continues to track the master Controller.

(See Fig. 8.1, page 91 for details of parallel connection).

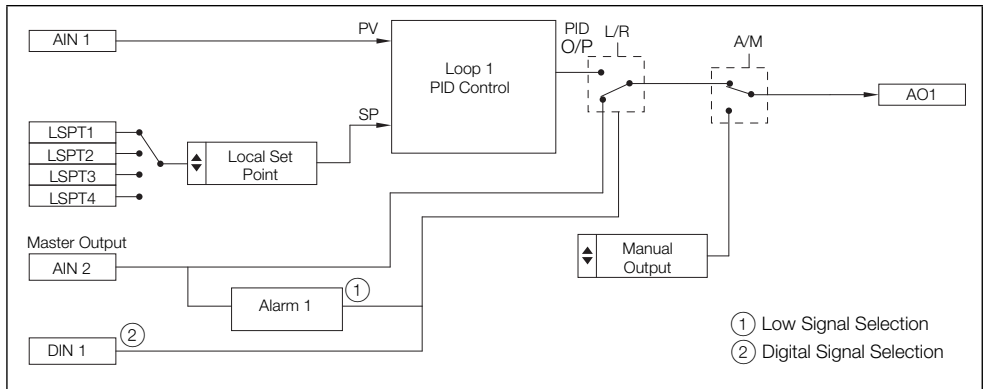

The auto-manual station and analog backup station templates can be used in series or in parallel with the master output signal. Parallel operation is achieved by using an external relay that is triggered by a relay on the ControlMaster, and selects the output to be routed to the process. This setup allows uninterrupted control, even in the event of failure of either the master controller or ControlMaster.

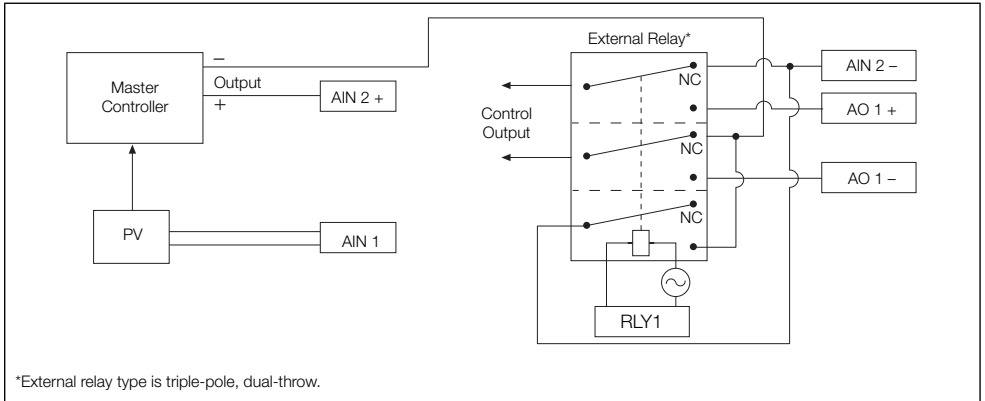
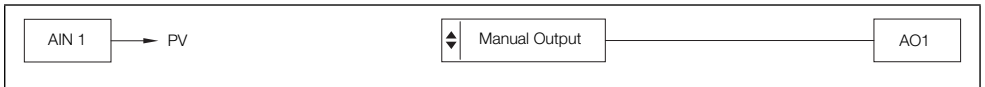

Fig. 8.1 Parallel Connection

8.2.3 Single Indicator

The Single Indicator template is used to display one process variable on the digital display.



8.2.4 Dual Indicator

The Dual Indicator template is used to display two process variables on the digital display.

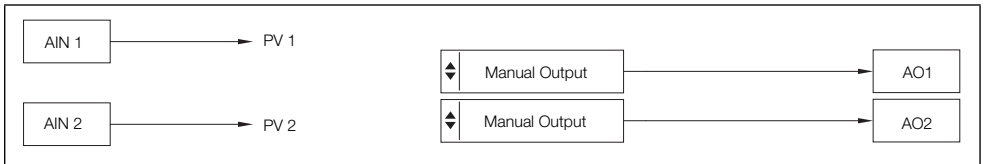

8.3 Extended Templates

8.3.1 Feedforward / Feedforward with Remote Setpoints

This template allows for an extra (disturbance) variable which is weighted by the feedforward gain and bias values to be then added to the controller output value. When in manual mode the PID output tracks the difference between the control output value and the feedforward signal to ensure bumpless transfer back in to auto mode.

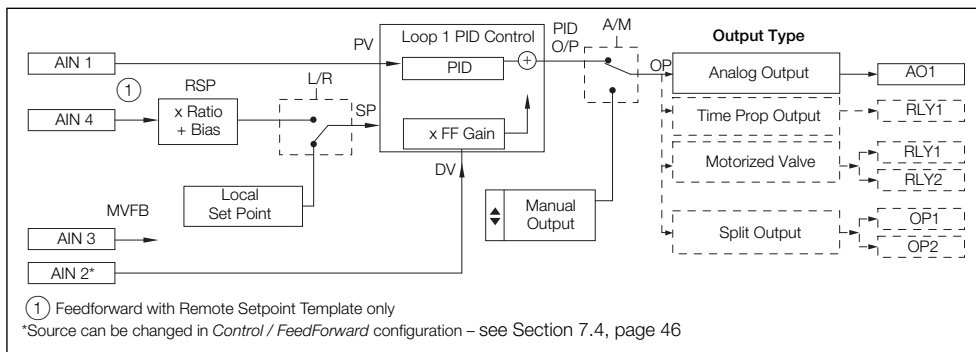

8.3.2 Cascade / Cascade with Remote Setpoints

This template connects 2 PID loops together in order to enhance the control of a Master variable (loop) by manipulation of a slave loop. The first (master) controller provides the set point for the second (slave) Controller. The 2 controllers are linked internally.

The Master output can be weighted using the Cascade ratio and bias values to create the Slave setpoint value. When the auto/manual mode is changed via the front panel or by a digital signal both the master and slave controllers change mode. In manual mode the slave setpoint can be adjusted by the user and the value is tracked by the master controller to ensure bumpless transfer back into auto mode.

Notes.

When selecting a Cascade application template, Logic Equation 1 is pre-configured as part of the Cascade Logic. Changing this equation prevents correct operation of the Cascade application template.

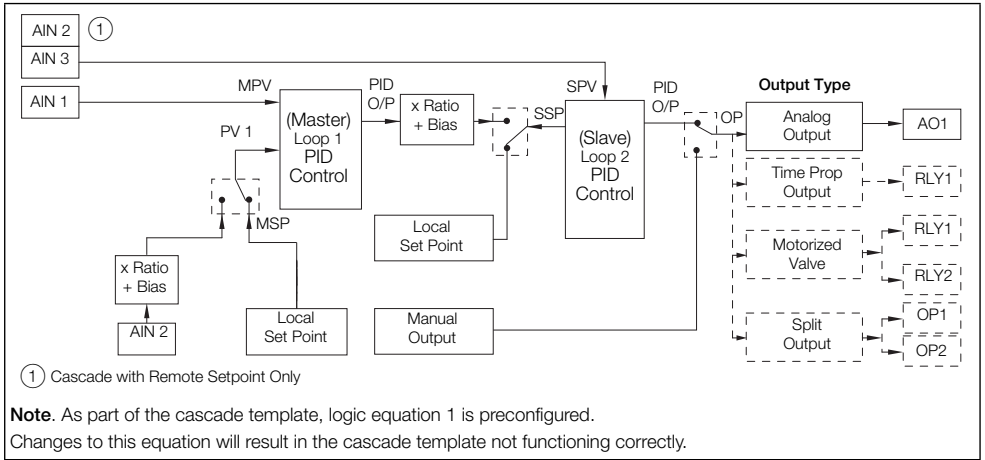

8.3.3 Cascade with Feedforward

This template connects 2 PID loops together in order to enhance the control of a Master variable (loop) by manipulation of a slave loop. The first (master) controller provides the set point for the second (slave) Controller. The 2 controllers are linked internally.

To the Master output a feedforward signal is added. This signal is a disturbance variable which is weighted by the feedforward ratio and bias values. When the auto/manual mode is changed via the front panel or by a digital signal both the master and slave controllers change mode, the slave setpoint can then be adjusted from the front panel, and this value is then tracked by the Master controller (taking account of the feedforward signal) to ensure a bumpless transfer back into auto mode.

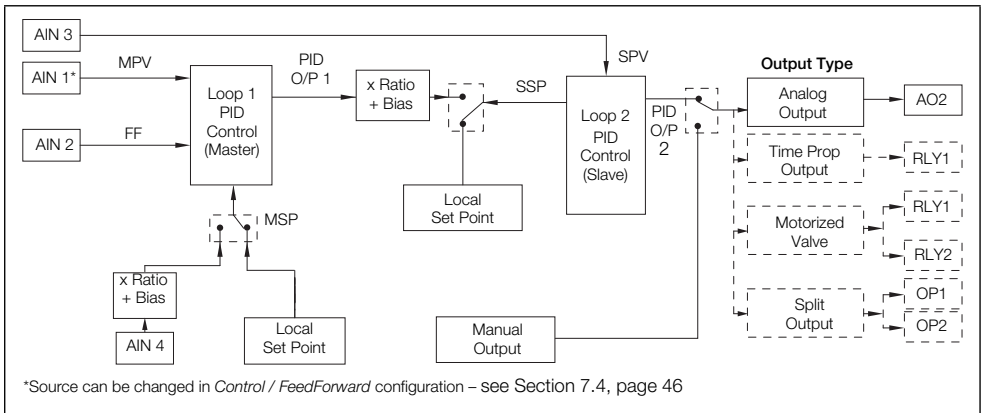

8.3.4 Ratio Controller (Internal / External Ratio)

The ratio controller template configures the ControlMaster to regulate one process variable against another based on a specified ratio. The unregulated variable or 'wild' variable is weighted by ratio and bias values and this forms the control setpoint for the process variable. The ratio value applied to the wild variable can either be a local value set on the front panel or a remote signal on an analog input.

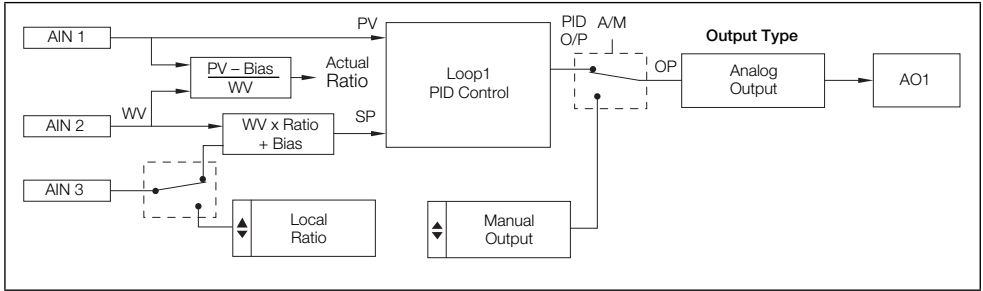

8.3.5 Ratio Station (Internal / External Ratio)

The ratio station template configures the ControlMaster as an Indicator and setpoint generator. The unregulated 'wild' variable is weighted with ratio and bias values and is then retransmitted to a slave controller.

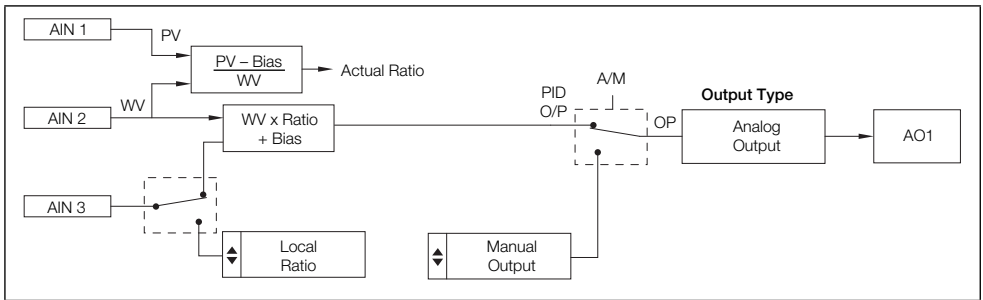

8.4 Dual Loop Templates

▲
 Dual loop templates allow the ControlMaster to act as 2 independent single-loop controllers. These templates are available with remote setpoint for either, or both control loops. This allows the same output options seen on the single loop template.

8.4.1 Dual Loop – Local Setpoint / Local Setpoint

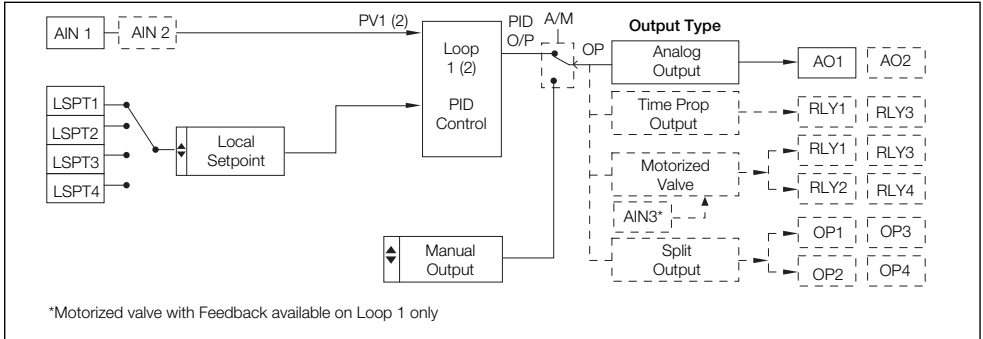

8.4.2 Dual Loop – Remote Setpoint / Local Setpoint

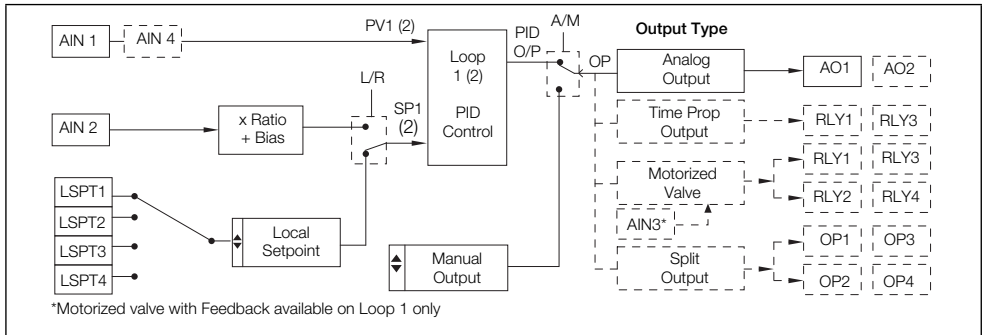

8.4.3 Dual Loop – Remote Setpoint / Remote Setpoint

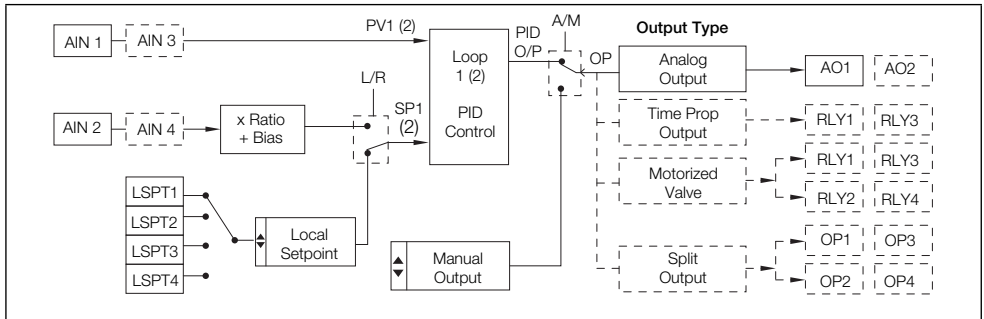

9 PC Configuration

In addition to local configuration via the front panel keys, the controller can be configured from a PC via the infrared port using the ConfigPilot PC configuration software. The controller's infrared port is activated when accessing the following page in the Advanced level:

Advanced>Device Setup>IrDA Configuration>Connect

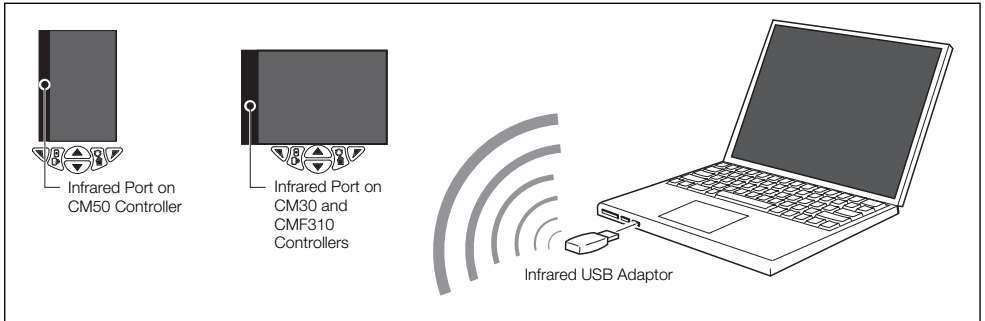

Fig. 9.1 PC Configuration via Infrared Port

10 Specification

Operation

Display

Color 1/4 VGA TFT, liquid crystal display (LCD) with built-in backlight

Language

English, German, French, Italian and Spanish

Operator keypad

6 Tactile membrane keys

Trend display

Recording of 2 variables

Configurable sample rate (1 second to 5 minutes)

272 samples displayed on screen

Security

Password protection

Basic / Advanced – user-assigned password protection (not set at factory)

Standard functions

Control strategies

Basic templates	Single loop with local setpoint Single loop with remote setpoint
Standard templates	Auto/Manual station (low signal detection) Auto/Manual station (digital signal selection) Analog backup station (low signal detection) Analog backup station (digital signal selection) Single indicator / manual loader station Dual indicator / manual loader station
Extended templates	Single loop with feedforward Single loop with feedforward and remote setpoint Cascade Cascade with remote setpoint Cascade with feedforward Ratio controller with internal ratio Ratio controller with external ratio Ratio station with internal ratio Ratio station with external ratio
Dual loop templates	Dual loop with local setpoints Dual loop with remote setpoint on 1 and local setpoint on 2 Dual loop with remote setpoint on both

Control output types

Current proportioning

Time proportioning

On / Off

Motorized valve with feedback

Motorized valve without feedback

Split output – with combinations of relay, digital O/P and current O/Ps

Control parameters

Proportional band* 0 to 999.9 %

Integral* 0 to 10000 s

Derivative* 0 to 999.9 s

Manual Reset 0.0 to 100 %

*3 sets of PID parameters when used with Gain Scheduling

Setpoints

Local 4 local set points, all selectable via digital inputs or front panel

Remote selectable via digital input or front panel keys

Profile (CMF310 only) 1 program, 10 segments
30 programs, 140 segments*

Autotune

On-demand calculation of control settings

Process alarms

Number	8
Types	High / Low process High / Low latch
Source	Fully configurable (for example, PV, analog input, math block inbuilt, OP control loop deviation)
Hysteresis	Level and time
Alarm enable	Enable / Disable of individual alarms via a digital signal

Acknowledgement

Via front panel keys or digital signals

Real-time alarms*

Number	2
Programmable	Time Day Duration

*Functionality level 'Standard' and above only

Maths blocks*

Number	8
Operators	+, -, x, /
	Average, Maximum, Minimum
	High / Low / Median Select
	Square root
	Multiplexer

Delay timers*

Number	2
Programmable	Delay
	Duration

Logic Equations*

Number	8
Elements	15 per equation
Operators	OR, AND, NOR, NAND, NOT, EXOR

Custom linearizer*

Number	2
Elements	20 breakpoints

Bank control*

Number of outputs	6
Wear levelling	Rotate or FIFO

Totalizer**

Number	2 (freely assignable) 9 digit total
Type	Analog, digital, frequency or pulse
Statistical calculations	Average, maximum, minimum (for analog signals)
Update rate	125 ms

Analog inputs

Universal process inputs

Number	2 (1 standard, 1 optional)
Type	Voltage
	Current
	Resistance (ohms)
	3-Wire RTD
	4-Wire RTD (CMF310 only)
	Thermocouple
	Digital volt-free
	Digital 24 V
	Frequency (Input 1)
	Pulse

Non-universal process inputs

Number	2 (1 standard, 1 optional)
Type	Voltage
	Current
	Thermocouple***
	Digital volt-free
	Digital 24 V

Thermocouple types

B, E, J, K, L, N, R, S, T

Resistance thermometer

Pt100

Other linearizations

\sqrt{x} , $x^{3/2}$, $x^{5/2}$, custom linearization

Digital filter

Programmable 0 to 60 s

Display range

-9999 to 99999

Update rate

125 ms

Common mode noise rejection

>120 dB at 50 / 60 Hz with 300 Ω imbalance resistance

Normal (series) mode noise rejection

>60 dB at 50 / 60 Hz

CJC rejection ratio

0.050 $^{\circ}\text{C}$ / $^{\circ}\text{C}$ change in ambient temperature

Temperature stability

0.02 % / $^{\circ}\text{C}$ or 2 μV / $^{\circ}\text{C}$ (1 μV / $^{\circ}\text{F}$)

Long term (input) drift

<0.1 % of reading or 10 μV annually

Input impedance

>10 M Ω (millivolts input)
10 Ω (mA input)

*Functionality level 'Standard' and above only

**Functionality level 'Extended'

***Only if universal input 1 on the same input module is configured as 'Thermocouple'

Inputs

Thermocouple	Maximum Range °C (°F)	Accuracy (% of reading)
B [#]	-18 to 1800 (0 to 3270)	0.1 % or ±2 °C (3.6 °F) (above 200 °C [392 °F]) *
E	-100 to 900 (-140 to 1650)	0.1 % or ±0.5 °C (0.9 °F)
J	-100 to 900 (-140 to 1650)	0.1 % or ±0.5 °C (0.9 °F)
K	-100 to 1300 (-140 to 2350)	0.1 % or ±0.5 °C (0.9 °F)
L	-100 to 900 (-140 to 1650)	0.1 % or ±1.5 °C (2.7 °F)
N	-200 to 1300 (-325 to 2350)	0.1 % or ±0.5 °C (0.9 °F)
R [#]	-18 to 1700 (0 to 3000)	0.1 % or ±1 °C (1.8 °F) (above 300 °C [540 °F])
S [#]	-18 to 1700 (0 to 3000)	0.1 % or ±1 °C (1.8 °F) (above 200 °C [392 °F])
T [#]	-250 to 300 (-400 to 550)	0.1 % or ±0.5 °C (0.9 °F) (above -150 °C [-238 °F])

For B, R, S and T thermocouples, accuracy is not guaranteed below the value stated.

RTD	Maximum Range °C (°F)	Accuracy (% of reading)
Pt100	-200 to 600 (-325 to 1100)	0.1 % or ±0.5 °C (0.9 °F)

Linear Inputs	Standard Analog Input	Accuracy (% of reading)	
		CM30 / CM50	CMF310
Millivolts	0 to 150 mV	0.1 % or $\pm 20 \mu\text{V}$	0.1 % or $\pm 20 \mu\text{V}$
Milliamps	0 to 45 mA (CM30 and CMF310) 0 to 50 mA (CM50)	0.2 % or $\pm 4 \mu\text{A}$	0.2 % or $\pm 10 \mu\text{A}$
Volts	0 to 25 V	0.2 % or $\pm 20 \text{mV}$	0.2 % or $\pm 20 \text{mV}$
Resistance Ω (low)	0 to 550 Ω	0.2 % or $\pm 0.1 \Omega$	0.2 % or $\pm 1 \Omega$
Resistance Ω (high)	0 to 10 k Ω	0.5 % or $\pm 10 \Omega$	0.1 % or $\pm 5 \Omega$
Sample Interval	125 ms per sample		

Digital Inputs	
Type	Volt-free or 24 V
Minimum pulse duration	Analog inputs 1 and 2: <ul style="list-style-type: none"> ■ Single inputs configured – 250 ms ■ Both inputs configured as analog or digital – 500 ms Analog inputs 3 and 4: <ul style="list-style-type: none"> ■ Single inputs configured – 250 ms ■ Both inputs configured as analog or digital – 500 ms Consider analog inputs 1 / 2 and 3 / 4 independently
Volt-free	Contact open > 10 M Ω / contact closed < 100 k Ω

Frequency input*	
Frequency range	0 to 6000 Hz
1-signal	15 to 30 V
0-signal	-3 to 5 V

*For use with devices with open collector outputs

Outputs

Controls / retransmission outputs

Number	CM30 / CM50: 2 (1 standard, 1 optional) CMF310: 4 (2 standard, 2 optional)
Type	Configurable as analog or digital pulse
Isolation	Galvanically isolated from the rest of the circuitry, 500 V for 1 minute
Analog range	0 to 20 mA Programmable
Load	750 Ω Max.
Accuracy	0.25 % of output or +/- 10 µA

Relays

Number	CM30: 4 (1 standard, 3 optional) CM50: 4 (2 standard, 2 optional) CMF310: 6 (4 standard, 2 optional)
Type	CM30: Standard with changeover contacts. Optional contacts selectable as N/O or N/C (by jumper) CM50: Selectable as N/O or N/C (by jumper)
Contact ratings	CM30 / CM50: 5 A, 240 V CMF310: 2 A 240 V
Update rate	125 ms

Digital input / output

Number	CM30 / 50 / CMF310: 6 (2 standard, 4 optional)
Type	User-programmable as input or output Minimum input pulse duration – 125 ms <ul style="list-style-type: none"> ■ Input <ul style="list-style-type: none"> – volt-free (contact open > 10 MΩ / contact closed < 100 kΩ) – 24 V DC (1-signal 15 to 30 V / 0-signal –3 to 5 V) – TTL (low: 0 to 0.8 V / high: 2 to 5 V) – Conforms to IEC 61131-2 ■ Output <ul style="list-style-type: none"> – Open collector output – 30 V, 100 mA max. – Conforms to IEC 61131-2
Update rate	125 ms

2-Wire transmitter power supply

Voltage	24 V DC (CM30/50 only)
Number	CM30 / CM50: 2 (1 standard, 1 optional) CMF310: 1 (optional)
Drive	2 Loops for each transmitter PSU, 45 mA max.

Communications

For MODBUS and Ethernet communications – see separate User Guide (IM/CM/C-EN).

Infrared port

Baud rate	up to 115 kBaud
Distance	up to 1 m
Functions	firmware upgrade, configuration upload / download

EMC

Emissions & immunity

Meets requirements of IEC61326 for an Industrial Environment

Environmental

Operating temperature range

–0 to 55 °C (32 to 131 °F)

Operating humidity range

5 to 95 %RH (non-condensing)

Storage temperature range

–20 to 70 °C (–4 to 158 °F)

Enclosure sealing

CM30 / CM50	
Front face	IP66 / NEMA 4X
Rest of enclosure	IP20
CMF310	
Front face and rest of enclosure	IP66 / NEMA 4X

Vibration (CM30, CM50)

Conforms to EN60068-2-6

Safety

Approvals and certifications

EN61010-1
 cULus

General safety

CM30 / CM50: Pollution Degree 2, Insulation Class 2
 CMF310: Pollution Degree 2, Insulation Class 1

Isolation (to inputs)

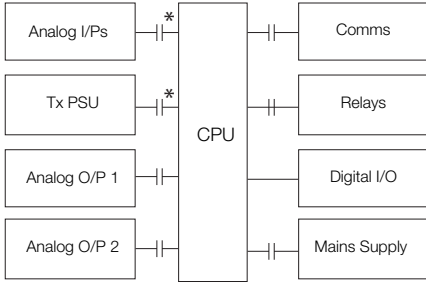

Key

—||— = Isolation
 *Isolated on CMF310 only

Physical

Size

CM30 97 x 97 x 141 mm (3.8 x 3.8 x 5.5 in.)
 CM50 144 x 76 x 146 mm (5.6 x 3.0 x 5.7 in.)
 CMF310 214 x 194 x 98 mm (8.42 x 7.64 x 3.85 in.)

Weight

CM30 0.5 kg (1.1 lb) approx. (unpacked)
 CM50 0.57 kg (1.27 lb) approx. (unpacked)
 CMF310 1.5 kg (3.3 lb) approx. (unpacked)

Panel cutout

CM30 92 x 92 mm (3.6 x 3.6 in.),
 121 mm (4.8 in.) behind panel
 CM50 138 x 68 mm (5.4 x 2.7 in.),
 123 mm (4.9 in.) behind panel
 CMF310 186 x 186 mm (7.32 x 7.32 in.)
 92 mm (3.6 in.) behind panel

Case material

Glass-filled polycarbonate

DS/CM30-EN Rev. P
 DS/CM50-EN Rev. N
 DS/CMF310-EN Rev. D

Electrical

Supply ranges

100 to 240 V AC $\pm 10\%$
 (90 V min. to 265 V max.) 50 / 60 Hz
 CM30 / CM50: 10 to 36 V DC (optional)

Power consumption

CM30 /CM50 10 W max.
 CMF310 25 W max.

Power interruption protection

No effect for interrupts of up to 60 ms

Appendix A – Digital and Analog Sources

Note. Numbers in brackets indicate additional parameters, for example, *Alarm 1 (8) Ack. State* indicates that 8 *Alarm Ack. State* parameters are available.

A.1 Digital Sources

Source Name	Description [Comment]
Alarm 1 (8) Ack. State	Acknowledged alarm = 0 Unacknowledged alarm = 1
Alarm 1 (8) State	Alarm state
Anlg IP 1 (4) Fail	Analog Input Failure (active when the signal detected at the analog input is outside the fault detect level specified during configuration).
AO1 (2) Loop Break	Analog output
Delay Timer 1 (2)	Delay timer state
IP 1 (4) Digital State	Input 1 (4) digital state
Linearizer 1 (2) Fail	Custom linearizer failure
Logic Equation 1 (8)	Logic equation result
Loop 1 SP Mode	Setpoint mode selected 0 = Local, 1 = Remote
Loop 1 Auto Mode	Automatic control mode
Loop 1 Close Relay	Motorized valve close relay state
Loop 1 LSP 1 (4) State	Local setpoint state 1 = setpoint selected
Loop 1 Manual Mode	Manual control mode 1 = Manual
Loop 1 Open Relay	Motorized valve open relay state
Loop 1 TP OP1	Time proportioning output
Loop 1 Valve State	Motorized valve state
Loop 1 Valve Stuck	Motorized valve stuck state
Loop 1 Ctrl Track	Control track state
Math Block 1 (8) Fail	Maths failure
RTA 1 (2) State	Real time alarm state

Source Name	Description [Comment]
Softkey Toggle	Front panel soft key toggles the source's state
Softkey Edge	Front panel soft key sets the source active on key press
T1 (2) Int Pulse	Totalizer intermediate pulse – active for 1 second when the intermediate count is reached
T1 (2) Run State	Totalizer run state 1 = Totalizer running
T1 (2) Wrap Pulse	Totalizer wrap pulse If <i>Wrap Enable</i> is <i>On</i> – active for 1 second when the predetermined count is reached <i>Off</i> – active when the predetermined count has been reached and remains active until the totalizer is reset
Profile Run	1 = Running
Profile Hold	1 = Hold
Profile Holdback	1 = Hold (due to guaranteed Soak/Ramp)
Profile Wait	1 = Wait
Profile Reset	1 = Reset
Profile Prog. End	1 = End (active for 5 seconds)
Profile Seg. End	1 = End (active for 5 seconds)
Profile Event 1 : 8	1 = Event active
Profile PV Event	1 = Event active
Profile Time Event	1 = Event active

A.2 Analog Sources

Source Name	Description
Anlg IP 1 (4)	Analog input
Constant 1 (8)	Math block constant
Linearizer 1 (2)	Custom linearizer
Loop 1 Actual Ratio	Loop 1 (2) actual ratio. Applies to ratio application templates only
Loop 1 Control OP	Control output value
Loop 1 Deviation	Loop 1 (2) deviation
Loop 1 Feedforward	Loop 1 (2) output of feedforward block
Loop 1 LSP	Local setpoint loop
Loop 1 PV	Loop 1 (2) process variable
Loop 1 Ration	Loop 1 (2) desired ratio Loop
Loop 1 SP	Loop control setpoint
Loop 1 Split OP1	Loop 1 split output
Loop 1 Valve Pos	Motorized valve position
Loop Bias 1	Loop 1 desired bias
Math Block 1 (8)	Math block
PV1 (2) Average	Process variable average
PV1 (2) Max	Maximum value of process variable 1 (2)
PV1 (2) Min	Minimum value of process variable 1 (2)
T1 (2) Batch Total	Totalizer batch total *
T1 (2) Secure Total	Totalizer secure total *
User Value	(Profile only)
Volume 1 (2)	(Indicator only)

*For display only.

Appendix B – Error Codes

B.1 Configuration Error Codes

Configuration errors are generated when a signal assigned as a source for something has failed. Configuration errors are displayed as numerical codes and a description of each code is shown in the following tables:

Error Code	Error Description
1	Analog Input Value A1 (I/P 1)
2	Analog Input Value A2 (I/P 2)
3	Analog Input Value B1 (I/P 3 – CM50)
4	Analog Input Value B2 (I/P 4 – CM50)
5	Analog Input Value C1 (I/P 3 – CM30)
6	Analog Input Value C2 (I/P 4 – CM30)
9	Setpoint Selected LSPT Value 1
10	Setpoint Control Setpoint Value 1
11	Setpoint Selected Ratio Value 1
12	Setpoint Selected Bias Value 1
13	Setpoint Actual Ratio Value 1
14	Setpoint Selected LSPT Value 2
15	Setpoint Control Setpoint Value 2
16	Setpoint Selected Ratio Value 2
17	Setpoint Selected Bias Value 2
18	Setpoint Actual Ratio Value 2
19	Modbus Input Value 1
22	Totalizer Batch total 1
23	Totalizer Secure Total 1
24	Totalizer Batch total 2
25	Totalizer Secure Total 2
26	Maths Block Value 1
27	Maths Block Value 2
28	Maths Block Value 3
29	Maths Block Value 4
30	Maths Block Value 5
31	Maths Block Value 6
32	Maths Block Value 7
33	Maths Block Value 8
34	Maths Block Constant 1
35	Maths Block Constant 2
36	Maths Block Constant 3
37	Maths Block Constant 4
38	Maths Block Constant 5
39	Maths Block Constant 6
40	Maths Block Constant 7
41	Maths Block Constant 8
42	Control Output Value 1
43	Control Output Value 2
44	Dual Output Loop 1 Value 1
45	Dual Output Loop 1 Value 2
46	Dual Output Loop 2 Value 1
47	Dual Output Loop 2 Value 2

Error Code	Error Description
48	Mot Valve Output 1
49	Mot Valve Output 2
50	PV Maximum Value 1
51	PV Minimum Value 1
52	PV average Value 1
53	Volume Value 1
54	PV Maximum Value 2
55	PV Minimum Value 2
56	PV average Value 2
57	Volume Value 2
58	Customer Linearizer Value 1
59	Customer Linearizer Value 2
60	Profile User Value 1
61	Profile User Value 2
62	Mot Valve Position 1
63	Mot Valve Position 2
64	template Block PV Value 1
65	Template Block PV Value 2
66	Template Block Deviation Value 1
67	Template Block Deviation Value 2
68	Template Block Feed forward Value 1
69	Template Block Feed forward Value 2
70	Analog Input Fail State A1
71	Analog Input Fail State A2
72	Analog Input Fail State B1
73	Analog Input Fail State B2
74	Analog Input Fail State C1
75	Analog Input Fail State C2
76	Maths Block Fail State 1
77	Maths Block Fail State 2
78	Maths Block Fail State 3
79	Maths Block Fail State 4
80	Maths Block Fail State 5
81	Maths Block Fail State 6
82	Maths Block Fail State 7
83	Maths Block Fail State 8
84	Custom Linearizer Fail State 1
85	Custom Linearizer Fail State 2
94	Analog Input State A1 (I/P 1)
95	Analog Input State A2 (I/P 2)
96	Analog Input State B1 (I/P 3 – CM50)
97	Analog Input State B2 (I/P 4 – CM50)
98	Analog Input State C1 (I/P 3 – CM30)

Error Code	Error Description
99	Analog Input State C2 (I/P 4– CM30)
100	Setpoint Remote Mode State 1
101	Setpoint LSPT 1 Selected State 1
102	Setpoint LSPT 2 Selected State 1
103	Setpoint LSPT 3 Selected State 1
104	Setpoint LSPT 4 Selected State 1
105	Setpoint Remote Mode State 2
106	Setpoint LSPT 1 Selected State 2
107	Setpoint LSPT 2 Selected State 2
108	Setpoint LSPT 3 Selected State 2
109	Setpoint LSPT 4 Selected State 2
110	Digital Input State 1
111	Digital Input State 2
112	Digital Input State 3
113	Digital Input State 4
114	Digital Input State 5
115	Digital Input State 6
123	Totalizer Run State 1
124	Totalizer Wrap Pulse 1
125	Totalizer Intermediate Pulse 1
126	Totalizer Run State 2
127	Totalizer Wrap Pulse 2
128	Totalizer Intermediate Pulse 2
131	Logic Equation Result 1
132	Logic Equation Result 2
133	Logic Equation Result 3
134	Logic Equation Result 4
135	Logic Equation Result 5
136	Logic Equation Result 6
137	Logic Equation Result 7
138	Logic Equation Result 8
139	Real Time Alarm State 1
140	Real Time Alarm State 2
141	Alarm State 1
142	Alarm Ack State 1
143	Alarm State 2
144	Alarm Ack State 2
145	Alarm State 3
146	Alarm Ack State 3
147	Alarm State 4
148	Alarm Ack State 4
149	Alarm State 5
150	Alarm Ack State 5
151	Alarm State 6
152	Alarm Ack State 6
153	Alarm State 7
154	Alarm Ack State 7
155	Alarm State 8
156	Alarm Ack State 8
157	Time Prop State 1

Error Code	Error Description
158	Time Prop State 2
159	Time Prop State 3
160	Time Prop State 4
161	Control O/P Auto State 1
162	Control O/P Manual State 1
163	Control O/P Track Status 1
164	Control O/P Auto State 2
165	Control O/P Manual State 2
166	Control O/P Track Status 2
167	Analog O/P Loop break A1
168	Analog O/P Loop break B1
169	Mot Valve Close Relay State 1
170	Mot Valve Open Relay State 1
171	Mot Valve Sticking State 1
172	Mot Valve Tri State 1
173	Mot Valve Tri State 2
174	Mot Valve Close Relay State 2
175	Mot Valve Open Relay State 2
176	Mot Valve Sticking State 2
177	Delay Timer State 1
178	Delay Timer State 2
189	Toggle Signal
190	Edge Signal

B.2 Profile Error Codes

Error Code	Error Description
1	<i>Jump Target Invalid</i> Current active program is configured to jump to another program, upon the completion of this action it is found that the next program has been configured incorrectly.
2	<i>Retort Rampback Invalid</i> Retort Rampback value is a negative number and must be changed.
3	<i>Retort Previous Invalid</i> There is no previous segment therefore the program is unable to jump back to the last ramp rate.
4	<i>PV Invalid</i> The Process Variable has failed.
5	<i>Local Setpoint has Failed</i> The Local setpoint has become invalid. This may be that it has travelled outside of its permissible limits.
9	<i>Validation</i> The current program is configured incorrectly and therefore judged invalid by the software validation.

Appendix C – Analog Input Engineering Units

C.1 Standard Units

Unit	Description
%	%
% sat	% saturation
%dO2	% dissolved oxygen
%HCl	% hydrochloric acid
%N2	% nitrogen
%O2	% oxygen
%OBS	% obscuration
%RH	% relative humidity
A	amps
bar	bar
CUMEC	cubic metre per second
Custom Units	Refer to Section 7.1, page 34
deg C / F	degrees Celsius / Fahrenheit
Feet	imperial feet
ft ³ /d, ft ³ /h, ft ³ /m, ft ³ /s	cubic feet per day, hour, minute, second.
FTU	formazine turbidity units
g/d, g/h, g/l	grams per day, hour, liter
gal/d (UK)	imperial gallons per day
gal/d (US)	US gallons per day
gal/h (UK) / (US)	imperial / US gallons per hour
gal/m, s (UK) / (US)	imperial / US gallons per minute, second.
Hz	hertz
Inches	imperial inches
Kelvin	degrees Kelvin
kg/d, kg/h, kg/m	kilograms per day, hr., min.
kg/s	kilograms per sec.
kHz	kilohertz
l/d, l/h, l/m, l/s	liters per day, hour, min., sec.

Unit	Description
lb/d, lb/h, lb/m, lb/s	pounds per day, hour, minute, second.
m WG	meters water gauge
m ³ /d, m ³ /h, m ³ /m, m ³ /s	cubic meters per day, hour, minute, second..
mbar	millibar
mg/kg	milligrams per kilogram
Mgal/d (UK)	imperial mega gallons per day
Mgal/d (US)	US mega gallons per day
mho	conductance
MI/d, MI/h	megaliters per day, hour.
ml/h, ml/m	millilitres per hour, minute.
MI/s	megaliters per second
mS/cm, mS/m	milliSiemens per centimeter, meter
mV	millivolts
MV	megavolts
NTU	nephelometric turbidity units
pb	parts per billion
pH	potential Hydrogen
pm	parts per million
psi	pounds per square inch
S	Siemens
SCFM	standard cubic feet per minute
T/d, T/h, T/m	metric tonnes per day, hour, minute.
T/s	metric tonnes per second
ton/d, ton/h, ton/m, ton/s	imperial tons per day, hour, minute, second.
ug/kg	micrograms per kilogram
uS/cm, uS/m	microSiemens per centimeter / meter
uV	microvolts

Appendix D – Output Type Assignments

Output Type	AO 1	AO 2	DIO 1	DIO 2	RLY1	RLY2	RLY3	RLY4
Analog	OP	PV			ALM 1	ALM 2	ALM 3	ALM 4
Time Proportioning	PV	SP			OP	ALM 1	ALM 2	ALM 3
MValve + Feedback	PV	SP			Open V	Close V	ALM 1	ALM 2
MValve Boundless	PV	SP	OP 2		Open V	Close V	ALM 1	ALM 2
Split Output Analog / Relay	OP 1	PV			OP 2	ALM 1	ALM 2	ALM 3
Split Output Analog / Digital	OP 1	PV	OP 2		ALM 1	ALM 2	ALM 3	ALM 4
Split Output Relay / Relay	PV	SP			OP 1	OP 2	ALM 1	ALM 2
Split Output Relay / Digital	PV	SP	OP 2		OP 1	ALM 1	ALM 2	ALM 3
Split Output Digital / Relay	PV	SP	OP 1		OP 2	ALM 1	ALM 2	ALM 3
Split Output Digital / Digital	PV	SP	OP 1	OP 2	ALM 1	ALM 2	ALM 3	ALM 4
Split Output Analog / Analog	OP 1	OP 2			ALM 1	ALM 2	ALM 3	ALM 4

Notes

Products and customer support

Automation Systems

For the following industries:

- Chemical & Pharmaceutical
- Food & Beverage
- Manufacturing
- Metals and Minerals
- Oil, Gas & Petrochemical
- Pulp and Paper

Drives and Motors

- AC and 6 Drives, AC and DC Machines, AC Motors to 1kV
- Drive Systems
- Force Measurement
- Servo Drives

Controllers & Recorders

- Single and Multi-loop Controllers
- Circular Chart and Strip Chart Recorders
- Paperless Recorders
- Process Indicators

Flexible Automation

- Industrial Robots and Robot Systems

Flow Measurement

- Electromagnetic Flowmeters
- Mass Flowmeters
- Turbine Flowmeters
- Wedge Flow Elements

Marine Systems & Turbochargers

- Electrical Systems
- Marine Equipment
- Offshore Retrofit and Refurbishment

Process Analytics

- Process Gas Analysis
- Systems Integration

Transmitters

- Pressure
- Temperature
- Level
- Interface Modules

Valves, Actuators and Positioners

- Control Valves
- Actuators
- Positioners

Water, Gas & Industrial Analytics Instrumentation

- pH, Conductivity and Dissolved Oxygen Transmitters and Sensors
- Ammonia, Nitrate, Phosphate, Silica, Sodium, Chloride, Fluoride, Dissolved Oxygen and Hydrazine Analyzers
- Zirconia Oxygen Analyzers, Katharometers, Hydrogen Purity and Purge-gas Monitors, Thermal Conductivity

Customer support

We provide a comprehensive after sales service via a Worldwide Service Organization. Contact one of the following offices for details on your nearest Service and Repair Centre.

UK

ABB Limited
Tel: +44 (0)1480 475321
Fax: +44 (0)1480 217948

USA

ABB Inc.
Tel: +1 215 674 6000
Fax: +1 215 674 7183

Client Warranty

Prior to installation, the equipment referred to in this manual must be stored in a clean, dry environment, in accordance with the Company's published specification.

Periodic checks must be made on the equipment's condition. In the event of a failure under warranty, the following documentation must be provided as substantiation:

- A listing evidencing process operation and alarm logs at time of failure.
- Copies of all storage, installation, operating and maintenance records relating to the alleged faulty unit.

ABB Limited**Measurement & Analytics**

Howard Road, St. Neots
Cambridgeshire, PE19 8EU
UK

Tel: +44 (0)870 600 6122

Fax: +44 (0)1480 213 339

Mail: enquiries.mp.uk@gb.abb.com

ABB Inc.**Measurement & Analytics**

125 E. County Line Road
Warminster, PA 18974
USA

Tel: +1 215 674 6000

Fax: +1 215 674 7183

abb.com/measurement

We reserve the right to make technical changes or modify the contents of this document without prior notice. With regard to purchase orders, the agreed particulars shall prevail. ABB does not accept any responsibility whatsoever for potential errors or possible lack of information in this document.

We reserve all rights in this document and in the subject matter and illustrations contained therein. Any reproduction, disclosure to third parties or utilization of its contents – in whole or in parts – is forbidden without prior written consent of ABB.