

# AquaMaster 3 FET200

## Electromagnetic flowmeter Transmitter

The smart solution for  
remote applications



### Introduction

AquaMaster 3™ is a range of high performance electromagnetic flowmeters for the measurement of electrically-conductive fluids and is normally supplied as factory-configured, calibrated systems.

This User Guide provides end-user details for AquaMaster 3 close-coupled and remote transmitters.

When the meter is taken out of storage and installed for first use, remove the protective label (if fitted) from the front to enable light to activate the unit.

If the meter is not powered, connect any batteries or external supply as detailed in this manual.

For a comprehensive overview of publications available for the AquaMaster 3 transmitter, refer to the inside cover of this publication. Web links, QR code and reference numbers are also included.

# The Company

We are an established world force in the design and manufacture of instrumentation for industrial process control, flow measurement, gas and liquid analysis and environmental applications.

As a part of ABB, a world leader in process automation technology, we offer customers application expertise, service and support worldwide.

We are committed to teamwork, high quality manufacturing, advanced technology and unrivalled service and support.

The quality, accuracy and performance of the Company's products result from over 100 years experience, combined with a continuous program of innovative design and development to incorporate the latest technology.

## Quality Control

The UKAS Calibration Laboratory No. 0255 is just one of the ten flow calibration plants operated by the Company and is indicative of our dedication to quality and accuracy.



*UKAS Calibration Laboratory No. 0255*

## For more information...

Further publications for the AquaMaster 3 transmitter are available for free download from [www.abb.com/flow](http://www.abb.com/flow) (see links and reference numbers below) or by scanning this code:



Programming Guide

User Guide Supplement, MODBUS Tables

**search for or click on:**

[COI/FET2XX-EN](#)

[COI/FET2XX/MOD/TBL-EN](#)

## Contents

<b>1</b>	<b>Safety</b>	<b>3</b>
1.1	Electrical Safety	3
1.2	Symbols	3
1.3	Health & Safety	4
1.3.1	Battery Hazard, Handling, Shipping and Recycling / Disposal	5
1.4	Waste Electrical and Electronic Equipment (WEEE)	5
<b>2</b>	<b>Mechanical Installation</b>	<b>6</b>
2.1	Installation Conditions	6
2.2	Fitting the Vandal-Resistant Housing (Integral Transmitters Only)	8
2.3	Dimensions	9
2.3.1	Remote- and Close-Coupled Transmitter	9
2.3.2	Integral Transmitter and Vandal-Resistant Housing	10
2.3.3	External Battery Pack	10
2.4	GSM-Equipped Transmitters	11
2.4.1	GSM Antenna Installation	11
2.4.2	Connecting a Remote Antenna	13
2.4.3	Installing a SIM Card	13
<b>3</b>	<b>Electrical Installation</b>	<b>15</b>
3.1	Grounding	15
3.2	Connections	18
3.2.1	AquaMaster3 Sensor Connections (Remote or Close-Coupled only)	18
3.2.2	Fitting Tamper-Detection Seals	19
3.3	Input / Output Connections	20
3.3.1	Frequency Outputs	20
3.3.2	Alarm Interface	20
3.3.3	Input / Output Connections	21
3.3.4	ScanReader Interface (Option)	22
3.3.5	RS232 Local Computer Connection	22
3.3.6	Pressure Transducer (Optional)	23
3.3.7	MID Sealing / Anti-tamper Protection	23
3.4	MODBUS Connection	25
3.4.1	2-wire Connection	26
3.4.2	Host Computer Interface	26
3.4.3	Pull-up and Pull-down Resistors / Polarization	26
3.4.4	Termination Resistor	27
3.4.5	Cable Properties	27
3.5	Power Supply Connections	28
3.5.1	Fitting / Replacing Internal Batteries (Integral Transmitters Only)	28
3.5.2	External Battery Power Supply	30
3.5.3	Mains Power Supply	30
3.5.4	Renewable Energy Supply	31
<b>4</b>	<b>Start-Up and Operation</b>	<b>32</b>
4.1	Start-up	32
4.2	Display Activation	33
4.3	Display Information	33
4.4	Servicing Plugs and Sockets	33
4.4.1	Service Intervals	33
4.4.2	Equipment Required	34
4.4.3	Preparation	34
4.4.4	Disconnection	34
4.4.5	Order of Treatment	35
4.4.6	Stage 1 – Oxide Removal and Cleaning	35
4.4.7	Stage 2 – Oxide Prevention	36
4.4.8	Completion tasks	36

<b>5</b>	<b>Specification .....</b>	<b>37</b>
	<b>Appendix A – GSM-Equipped Units, Safety Precautions .....</b>	<b>42</b>
	<b>Appendix B Accessories / Spares Kits .....</b>	<b>43</b>
B.1	Common accessories .....	43
B.2	Adapter Cable / Upgrade Kits .....	44

# 1 Safety

Information in this manual is intended only to assist our customers in the efficient operation of our equipment. Use of this manual for any other purpose is specifically prohibited and its contents are not to be reproduced in full or part without prior approval of the Technical Publications Department.





## 1.1 Electrical Safety





This equipment complies with the requirements of CEI/IEC 61010-1:2010 'Safety Requirements for Electrical Equipment for Measurement, Control and Laboratory Use' and complies with US NEC 500 and Occupational Safety & Health Administration.

If the equipment is used in a manner NOT specified by the Company, the protection provided by the equipment may be impaired.

## 1.2 Symbols

One or more of the following symbols may appear on the equipment labelling:

	<b>Warning</b> – Refer to the manual for instructions
	<b>Caution</b> – Risk of electric shock
	Protective earth (ground) terminal
	Earth (ground) terminal

	Direct current supply only
	Alternating current supply only
	Both direct and alternating current supply
	The equipment is protected through double insulation

## 1.3 Health & Safety

### Health and Safety

To ensure that our products are safe and without risk to health, the following points must be noted:

- The relevant sections of these instructions must be read carefully before proceeding.
- Warning labels on containers and packages must be observed.
- Installation, operation, maintenance and servicing must only be carried out by suitably trained personnel and in accordance with the information given.
- Normal safety precautions must be taken to avoid the possibility of an accident occurring when operating in conditions of high pressure and / or temperature.
- Chemicals must be stored away from heat, protected from temperature extremes and powders kept dry. Normal safe handling procedures must be used.
- When disposing of chemicals ensure that no two chemicals are mixed.

Safety advice concerning the use of the equipment described in this manual or any relevant hazard data sheets (where applicable) may be obtained from the Company contact details on the back cover, together with servicing and spares information.

### Warning.

- Installation and maintenance must be carried out only by suitably trained personnel.
- Read all relevant sections of this manual before selecting a location.
- The safety requirements of this equipment, any associated equipment and the local environment must be taken into consideration during installation.
- Install and use this equipment in accordance with relevant national and local standards.
- Specific safety precautions apply to the use of the GSM engine that forms part of the GSM-equipped version of this product. If the unit purchased has GSM-capability, read Appendix A on page 42 before selecting a location.

### 1.3.1 Battery Hazard, Handling, Shipping and Recycling / Disposal

#### **Warning.**

AquaMaster is available with choice of battery technologies; Manganese Alkaline (part no WABC2100) or Lithium Thionyl Chloride (part no WABC2101 or WABC2102 or 'D' size cell). The following warnings must be observed:

- To ensure safety and correct operation, use only the batteries / battery packs listed in this manual or approved by ABB.
- Incorrect use or operation of batteries / battery packs may result in potentially serious hazards to personnel.
- DO NOT expose batteries / battery packs to fire or temperatures above 85 °C (185 °F) and DO NOT crush or puncture – they may leak, explode or rupture violently.
- DO NOT ship or transport the AquaMaster 3 Integral form with Lithium cells fitted unless the following instruction is complied with:
  - **Transporting Lithium Batteries / Battery Packs or product containing Lithium batteries / cells.** These are classified in 'category UN3091 – Class 9' of the UN list of hazardous materials. The transport of such cells / battery packs must conform to the prevailing rules that are specific to the means of transport used, both in terms of packing, identification and accompanying documents. The carrier must always be informed of the contents. A warning label 'Hazardous Label for Class 9 – Miscellaneous Hazardous Goods' must be attached to the packing and remain visible on the outside of the package.
- DO NOT dispose of depleted or partially depleted batteries. They MUST be recycled in accordance with local regulations (for example, sent to a specialist recycling centre that handles such batteries). The battery or battery pack must be packed, labelled and transported in accordance with the regulations. Ensure the battery cannot be short circuited.
- Recycling in Europe must be in accordance with 91/157/EEC and 93/86/EEC Directives.
- Damaged, leaking or overheated batteries require urgent specialist handling and treatment. Immediately evacuate all personnel from the area and seek professional assistance.

### 1.4 Waste Electrical and Electronic Equipment (WEEE)

WEEE EU Directives 2002/96/EC and 2003/108/EC cover disposal and recycling of electronic equipment at the end of life for reasons of environmental protection. Not all products are covered by the categories in this directive.



For industrial installations, portable equipment is included. This means that when the AquaMaster transmitter is used with a portable AquaProbe sensor, it is included in directive's scope and has the WEEE symbol (left) on its data label. Therefore, at the end of life, contact the supplier for specialist waste recycling. It must not be disposed of as municipal waste.

Permanent Industrial installations are not designated within this directive for recycling. At the point of supply the intended use is not always known, so the WEEE symbol is included on all remote forms of the AquaMaster transmitter.

## 2 Mechanical Installation

### 2.1 Installation Conditions

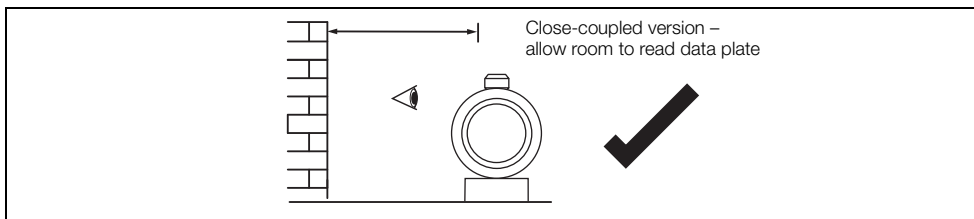

Fig. 2.1 Siting

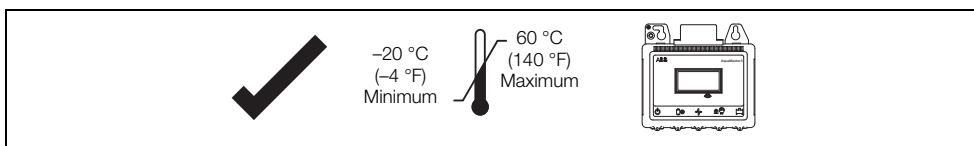

Fig. 2.2 Within Temperature Limits

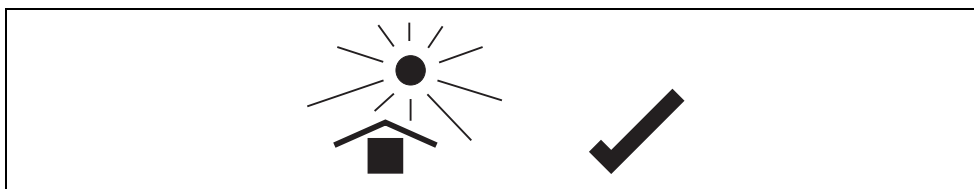

Fig. 2.3 Shade

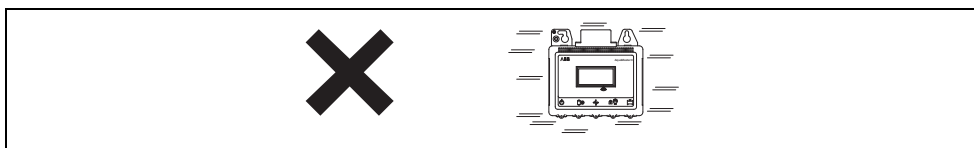

Fig. 2.4 Vibration

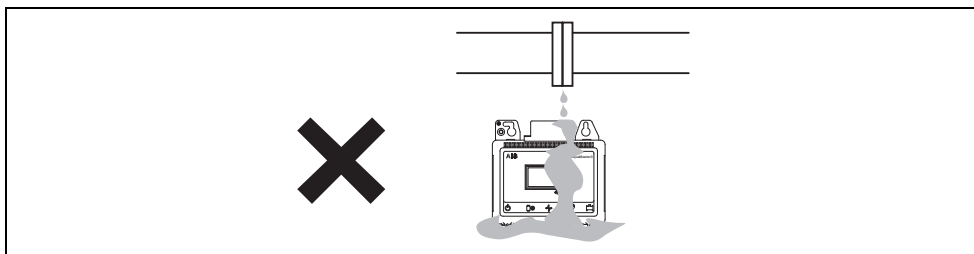

Fig. 2.5 Spillage



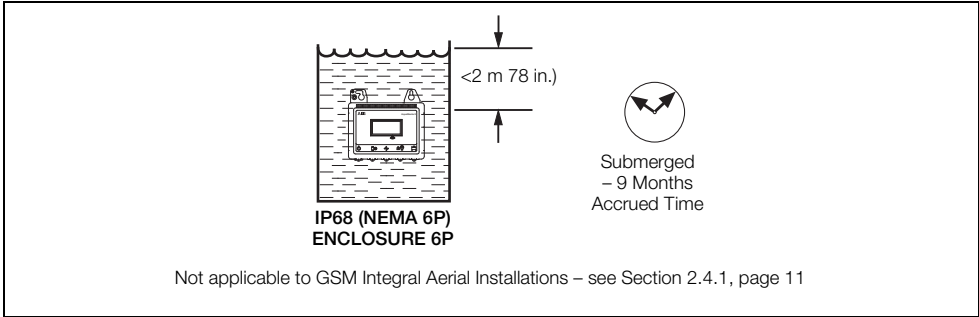

Fig. 2.6 Within Environmental Rating

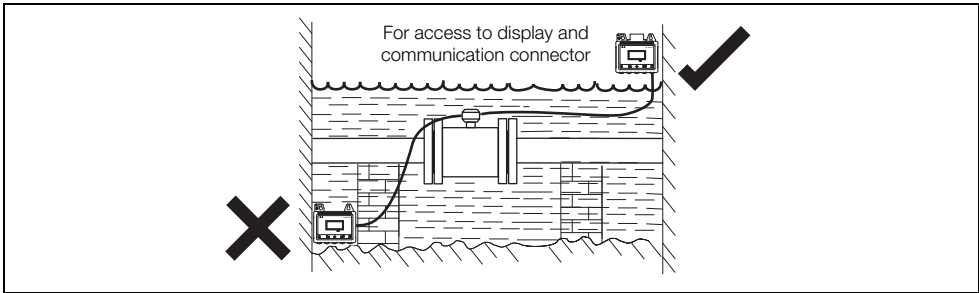

Fig. 2.7 Access to Transmitter

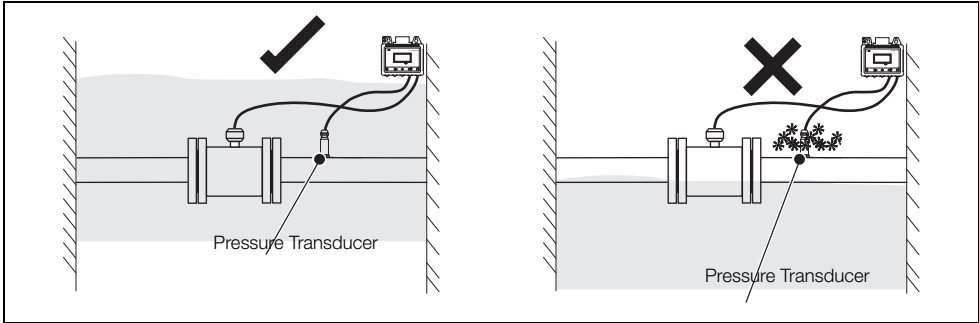

Fig. 2.8 Pressure Transducer – Protect from Frost

## 2.2 Fitting the Vandal-Resistant Housing (Integral Transmitters Only)

Referring to Fig. 2.9:

1. Slide cover (A) over transmitter.
2. Insert bottom plate (B) ensuring clips (C) enter lugs (D).
3. Secure with lock (E).

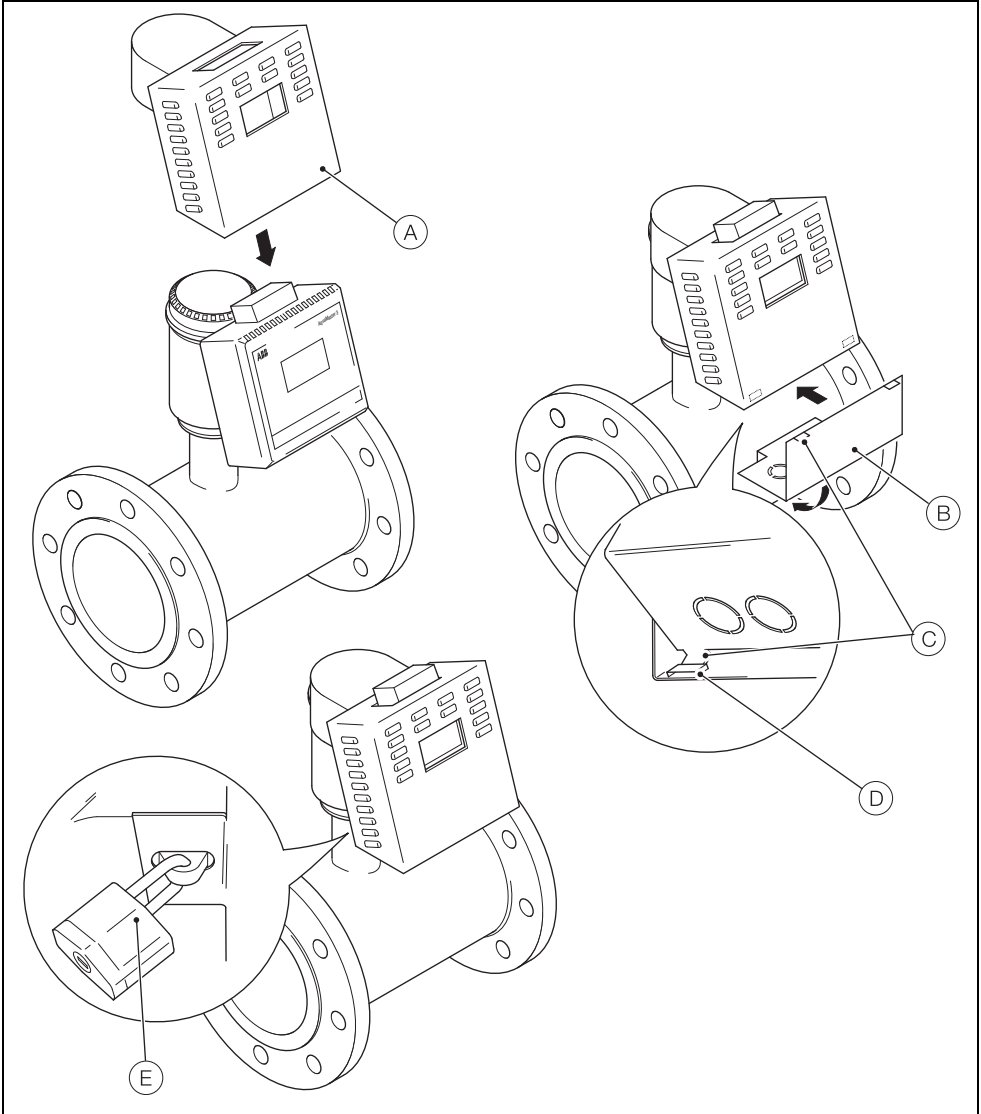

Fig. 2.9 Fitting Anti-Vandal Housing

### 2.3 Dimensions

#### 2.3.1 Remote- and Close-Coupled Transmitter

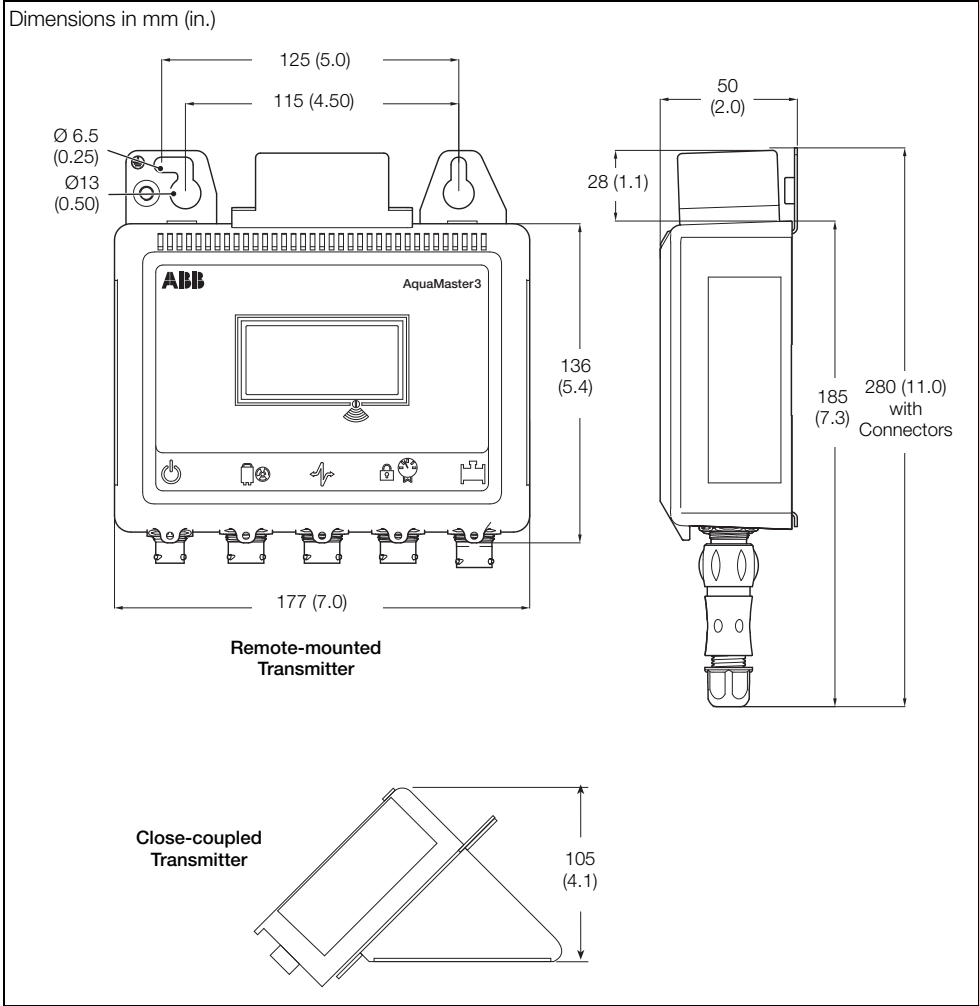

Fig. 2.10 AquaMaster3 Dimensions

### 2.3.2 Integral Transmitter and Vandal-Resistant Housing

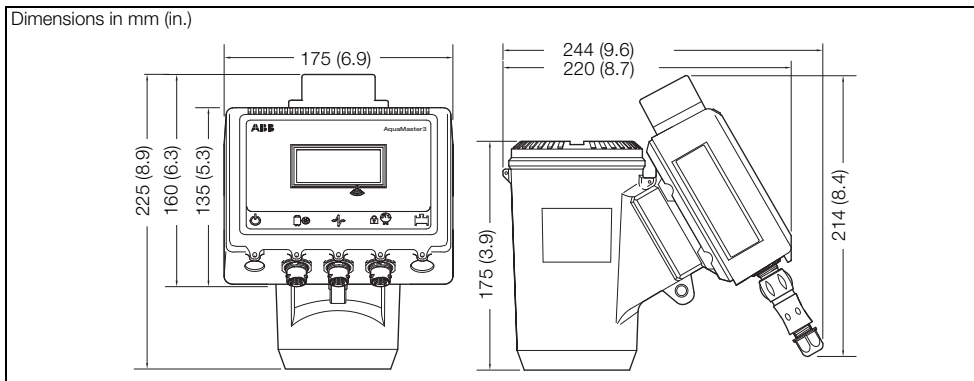

Fig. 2.11 Integral Transmitter Dimensions

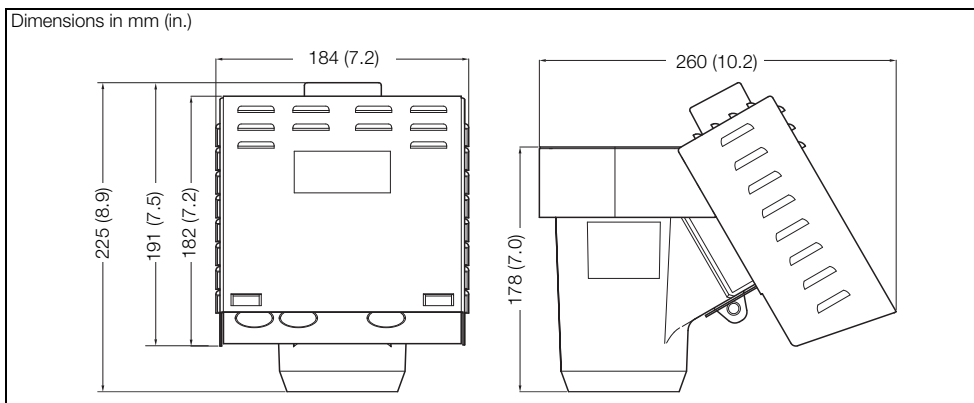

Fig. 2.12 Vandal-resistant housing dimensions

### 2.3.3 External Battery Pack

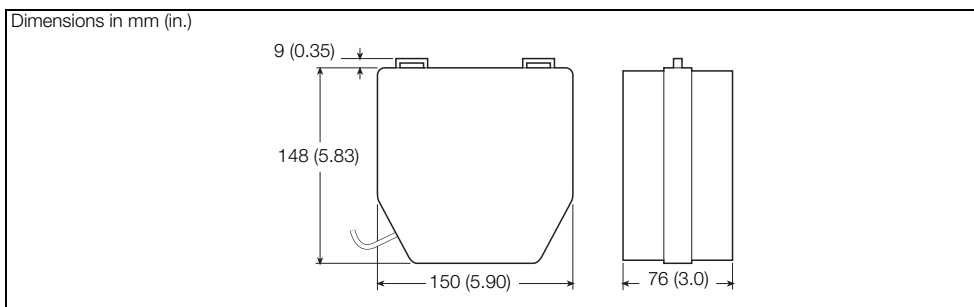

Fig. 2.13 AquaMaster3 Battery Pack Dimensions

## **2.4 GSM-Equipped Transmitters**

### **2.4.1 GSM Antenna Installation**

Before deciding on an antenna mounting location, check that the local signal strength for the chosen mobile phone network is satisfactory. Use the GSM-equipped transmitter's integral signal strength test facility to establish signal strength. Refer to Programming Guide (COI/FET2XX-EN), Section 5.

If a GSM-equipped transmitter is not available, a standard mobile phone on the same network, positioned as close as possible to the intended location, gives a good indication of local signal strength. For GSM and logger download services, a minimum of 2 visible signal strength indicator 'bars' are recommended. For SMS text, a minimum of 1 visible signal strength indicator 'bar' is recommended.

The following must also be observed when deciding on the antenna mounting location:

- For best results, mount the antenna as high above local ground level as possible.
- If the antenna must be mounted below ground, achieve optimum results by ensuring:
  - there is a strong mobile phone network signal at ground level
  - the antenna, mounted 50 mm (2 in.) below the chamber cover, must be plastic – see Fig. 2.14, page 12
- Ensure the antenna does not become submerged under water – see Fig. 2.14, page 12.
- Metallic enclosures seriously degrade the signal. If an enclosure is used it must be non-metallic.
- Do not mount the antenna closer than 50 mm (2 in.) to any solid wall or surface – see Fig. 2.15, page 12.
- Do not mount the antenna beneath a solid surface (for example, metal cover, floor / ceiling).

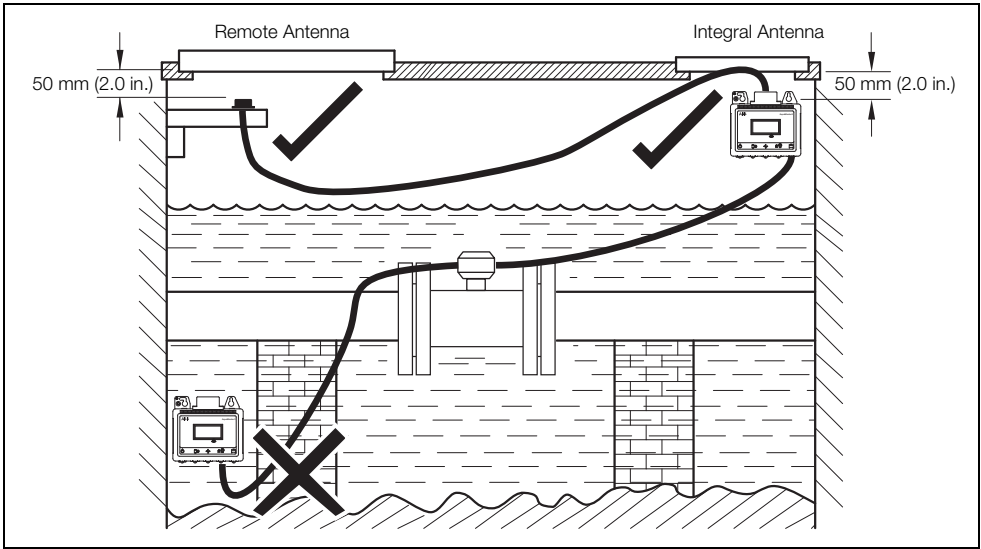

Fig. 2.14 GSM Antenna Installation

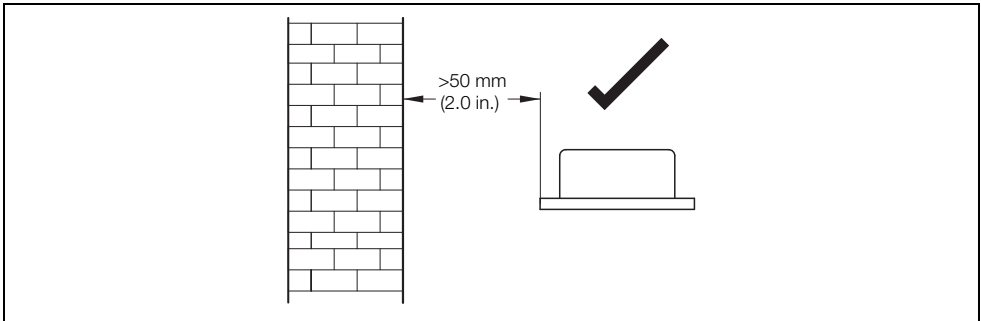

Fig. 2.15 GSM Antenna Installation

### 2.4.2 Connecting a Remote Antenna

Referring to Fig. 2.16:

1. Remove the cover (A) from the socket on top of the transmitter.
2. Gently push the antenna plug (B) into the socket, then twist the screw ring clockwise until locked.

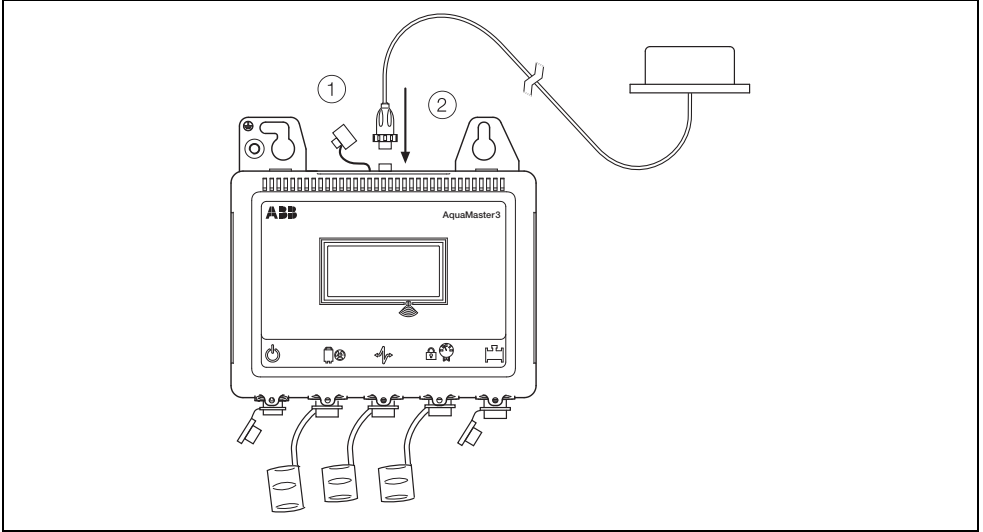

Fig. 2.16 Connecting a Remote Antenna

### 2.4.3 Installing a SIM Card

Referring to Fig. 2.17:

**Note.** Step 1 is applicable only to remote- and close-coupled transmitters.

1. Remove the transmitter from its mounting point.

**Note.** Step 2 is applicable only to integral transmitters.

2. Remove 4 x 4 mm Hex fixing screws (A) and remove the transmitter.
3. Use water to wash off any loose dirt from the case and dry the area around the SIM card cover.
4. On the back of the transmitter, unscrew and remove cover (B) protecting SIM card holder (C).
5. If the SIM card is being changed, ensure the GSM Engine is off before removing the card by reading >368 (see COI/FET2XX-EN) and ensuring the status reported is *Off*.
6. Carefully lift the right-hand edge of holder (C) outwards.

7. Slide SIM card (D) into holder (C), contact side down and bevelled edge to the top-right.
8. Close holder (C) until it clicks into place and refit cover (B).
9. Screw cover (B) firmly in place.

**Note.** Step 10 is applicable only to remote- and close-coupled transmitters.

10. Refit the transmitter to its mounting point.

**Note.** Step 11 is applicable only to integral transmitters.

11. Position the transmitter on the integral mount and secure with 4 x 4 mm Hex fixing screws (A).  
Tighten the screws to 4Nm.

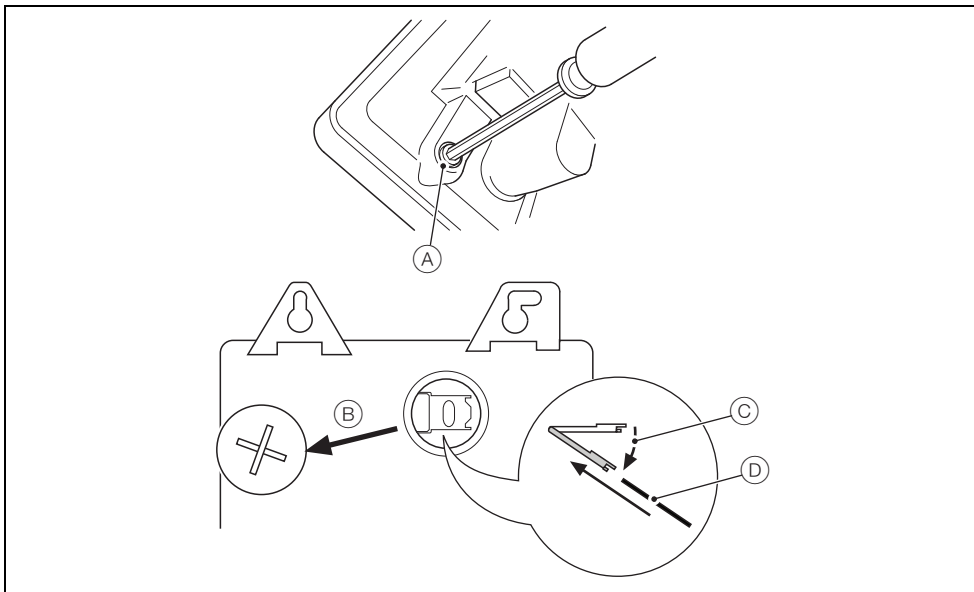

Fig. 2.17 Installing a SIM Card



### 3 Electrical Installation

#### 3.1 Grounding

**Note.** The grounding arrangements shown in Figs 3.1 to 3.3 are applicable to:

- new installations **ONLY**
- both cathodic and non-cathodic protected installations

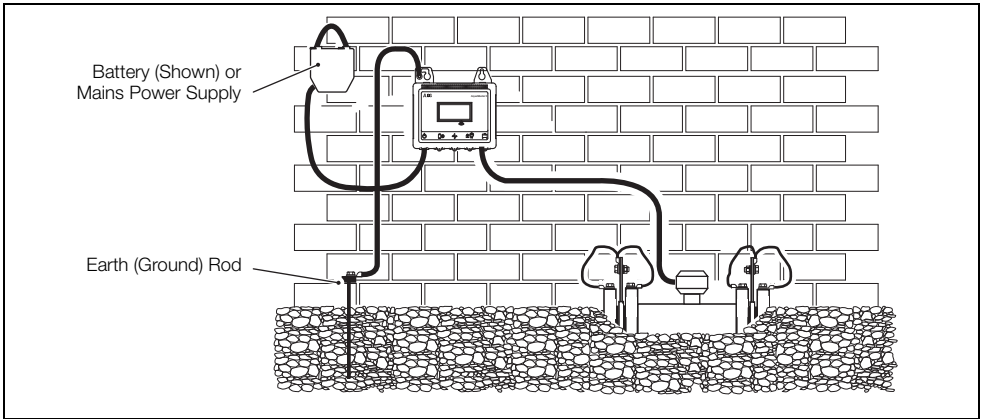

Fig. 3.1 AquaMaster3 Transmitter Mounted in a Chamber – Flanged Sensor

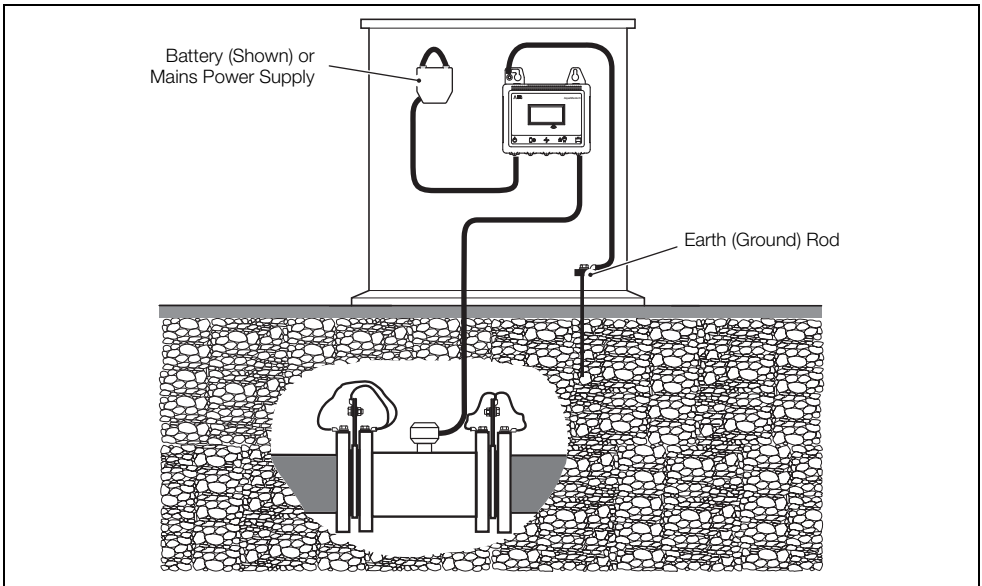

Fig. 3.2 AquaMaster3 Transmitter Mounted in a Cabinet – Flanged Sensor

**AquaMaster 3 FET200**  
Electromagnetic flowmeter

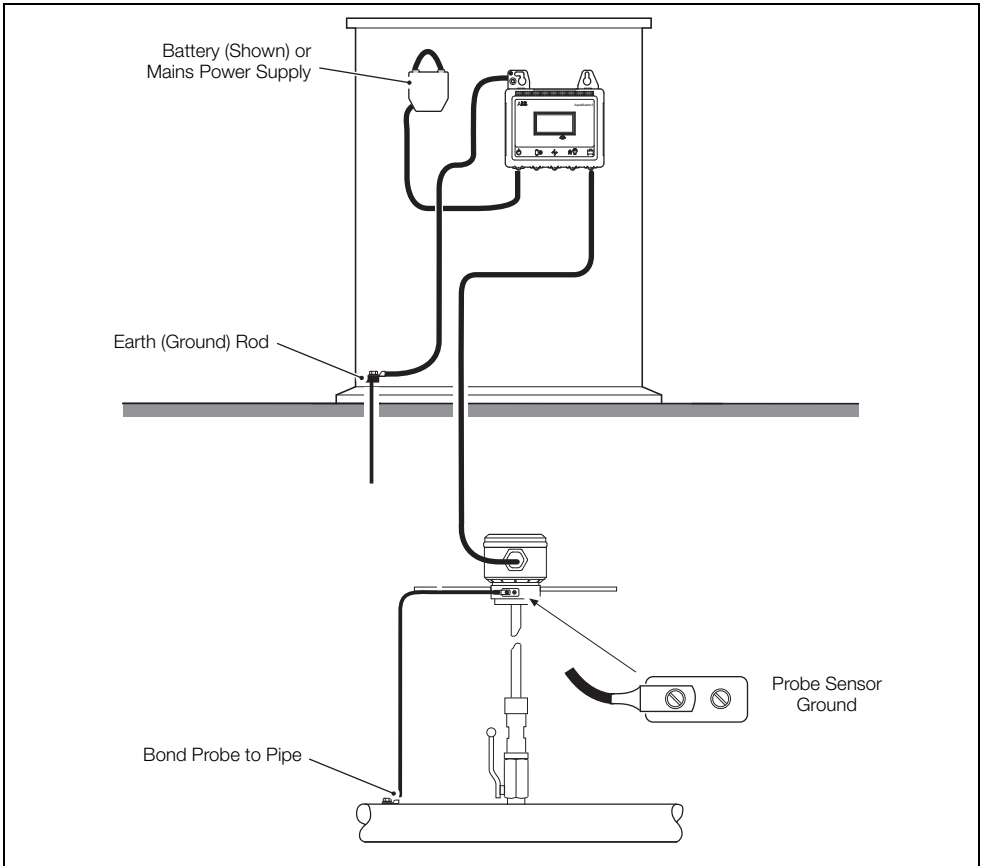

Fig. 3.3 AquaMaster3 Transmitter Mounted in a Cabinet – Probe Sensor

**Note.** The grounding arrangement shown in Fig. 3.4 is applicable only to:

- cathodic protected installations
- installations where  $E_2$  and  $E_3$  are different to  $E_1$

**Caution.** Incorrect installation will result in fault currents flowing through the meter resulting in unstable readings.

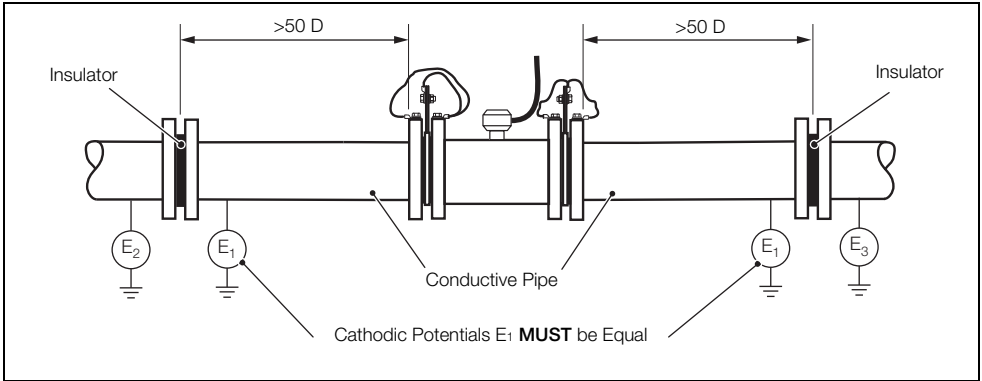

Fig. 3.4 Cathodic Protected Installations with Different Cathodic Potential Generators

## 3.2 Connections

**Note.** Refer to Section Fig. 3.4, page 25 for MODBUS connection.

### 3.2.1 AquaMaster3 Sensor Connections (Remote or Close-Coupled only)

Referring to Fig. 3.5:

1. Remove the screwed cap (A) on the sensor connector.
2. Gently push the sensor plug (B) into the socket and rotate it until it engages, then tighten the locking ring.

**Note.** If the sensor cable is terminated with fly leads, connection is via a sensor cable adapter box (part number WABC2035 available separately).

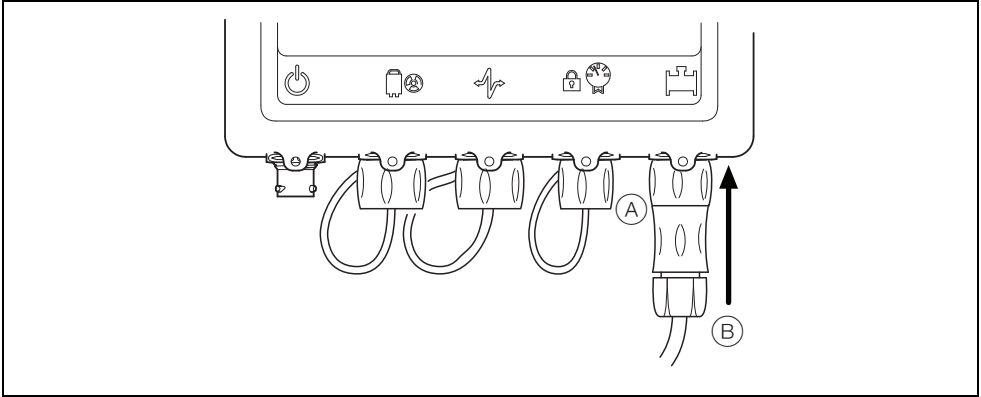

Fig. 3.5 Sensor Connections

### 3.2.2 Fitting Tamper-Detection Seals

It is a legal requirement for MID compliant flowmeters (see Section 3.3.7, page 23) to fit Tamper detection seals at installation to the following connections:

- Remote Sensor Connector (Fig 3.5, page 18)
- Pressure Connector fitted with MID Compliant shorting link (see Section 3.3.7, page 23)

Referring to Fig. 3.6:

1. Pass the wire of the seal through both the hole in the locking-ring and the matching hole in the front of the transmitter.
2. Close the seal.

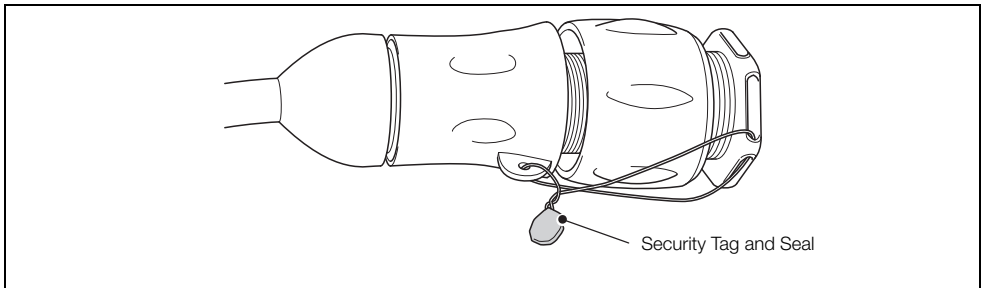

*Fig. 3.6 Using Tamper-Detection Seals*

### 3.3 Input / Output Connections

**Caution.**

- Refer to the Specification, Section 5, page 37 for input / output ratings.
- Inductive loads must be suppressed or clamped to limit voltage swings.
- Operation of outputs is programmable – see Programming Guide (COI/FET2XX-EN) for details.
- External isolators are not normally required as the pulse and alarm circuit is electrically-separated from all other AquaMaster3 connections.
- Capacitive loads must be inrush current limited.
- Fully-floating pulse outputs may be subject to static damage, for example connecting to a floating datalogger, unless 'COM' is operated within its galvanic isolation range ( $\pm 35$  V) from earth.

#### 3.3.1 Frequency Outputs

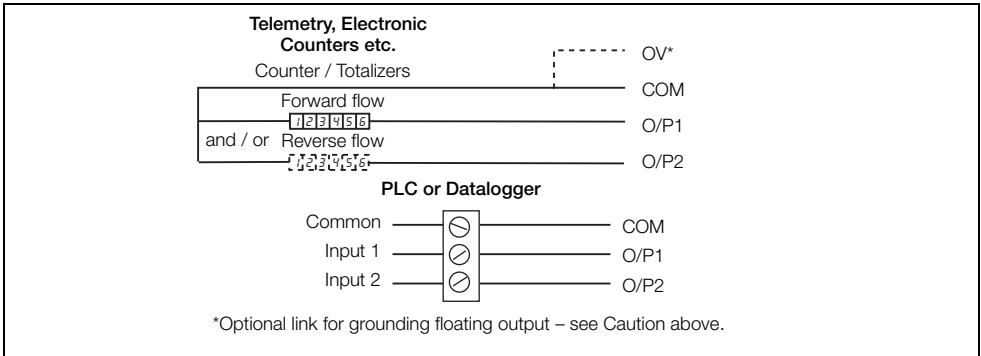

Fig. 3.7 Frequency Output Connections

**Note.** Outputs 1 and 2 are not polarity-sensitive. The common connection for these outputs is designated 'COM'.

#### 3.3.2 Alarm Interface

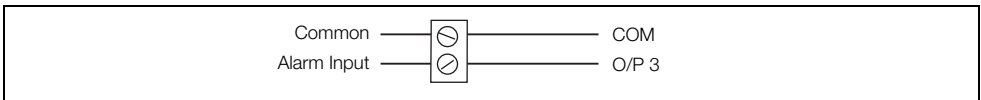

Fig. 3.8 Alarm Output Connections

**Note.** Output 3 is not polarity sensitive. The common connection for these outputs is designated 'COM'.

### 3.3.3 Input / Output Connections

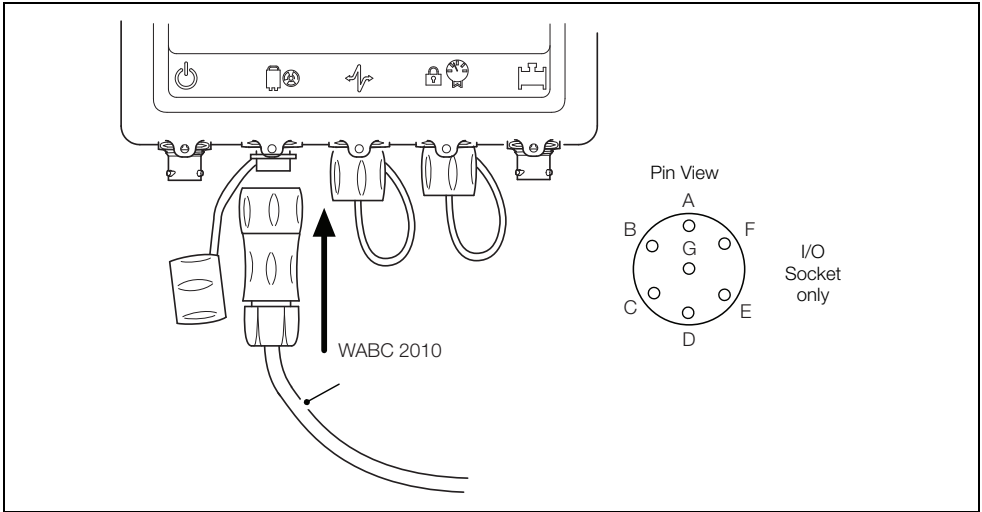

Fig. 3.9 Input / Output Connectors

Pin	Signal	Function	Color (Output Cable)
A	Not used	Not used	Violet
B	DATA	ScanReader Data	Blue
C	O/P COM	Output Common	Yellow
D	O/P2	Reverse Pulses or Direction Indicator	Red
E	O/P3	Alarm Output	Brown
F	O/P1	Forward Pulses or Forward & Reverse Pulses	Orange
G	0V	Scanreader 0V	Screen

Table 3.1 Connector Input / Output Connections

### 3.3.4 ScanReader Interface (Option)

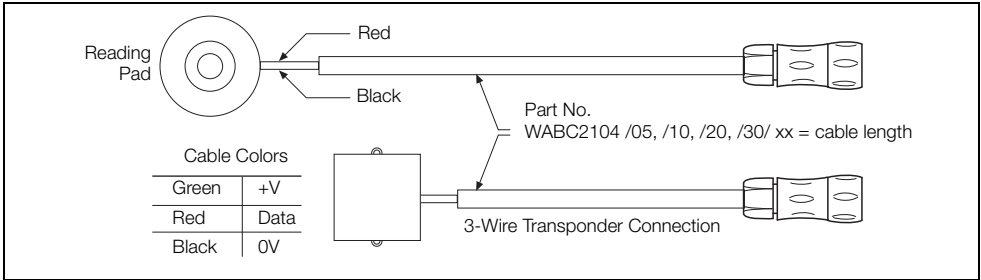

Fig. 3.10 ScanReader Connections

### 3.3.5 RS232 Local Computer Connection

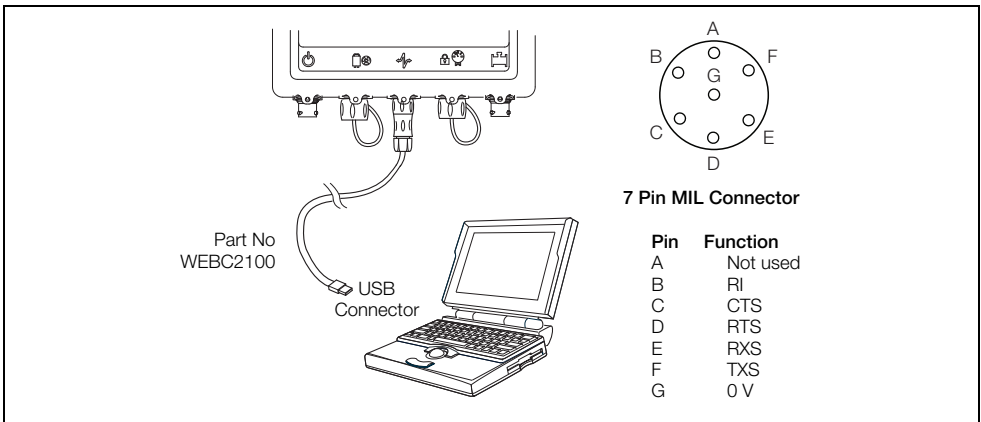

Fig. 3.11 RS232 Local Computer Connections

#### Note.

- A USB Comms lead driver is required when using WEBC2100 – download from [www.ftdichip.com/FTDrivers.htm](http://www.ftdichip.com/FTDrivers.htm)
- On battery or renewable energy versions, do not leave an RS232 connection plugged in or wired with voltages applied unnecessarily. Such voltages result in far higher power consumption from the battery or backup source, limiting battery / backup life.
- The serial port connection shares the same physical port as the MODBUS connection so (depending on cable design) it may be necessary to disconnect the MODBUS connection temporarily to enable configuration of AquaMaster3.



### 3.3.6 Pressure Transducer (Optional)

Optional pressure transducer cables are available for a range of pressures and cable lengths.

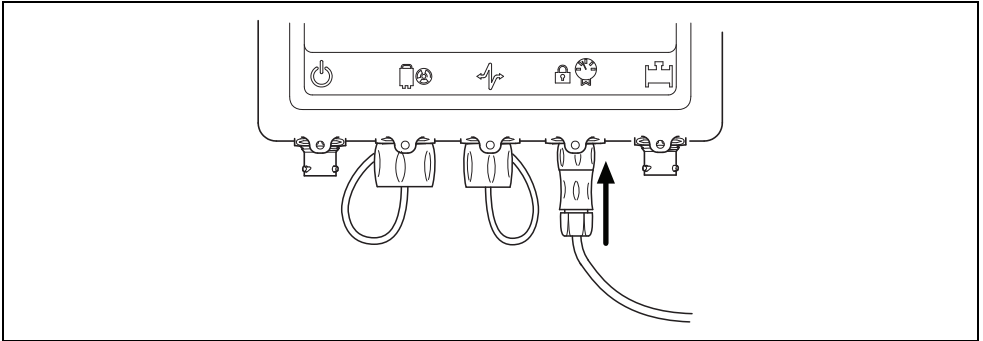

Fig. 3.12 Optional Pressure Transducer Connector

**Caution.** Use only the pressure transducer supplied with the transmitter. Use of other pressure transducers requires alteration of the pressure span and zero factors in the transmitter.

### 3.3.7 MID Sealing / Anti-tamper Protection

For flowmeters ordered with the Measuring Instruments Directive (MID) option / variant it is a legal requirement that at the end of installation the flowmeter is sealed to prevent unauthorized changes to the meter settings and configuration. A read-only switch / link is used (see Fig. 3.13, page 24) to prevent login through any communication means and modification of any parameters on the AquaMaster3. For MID flowmeters they must be fitted with either WEBC2054 or WEBC2025 connectors. A suitable anti-tamper seal (see Section 3.2.2, page 19) must be fitted to this connector, such that in the event of unauthorized tampering, it is clearly visible that the fitted legal metrology seals have been broken.

For MID remote sensor type flowmeters it is also essential, and a legal requirement, to fit a suitable anti-tamper seal, as illustrated in Section 3.2.2 to the sensor connector illustrated in Fig 3.5, page 18.

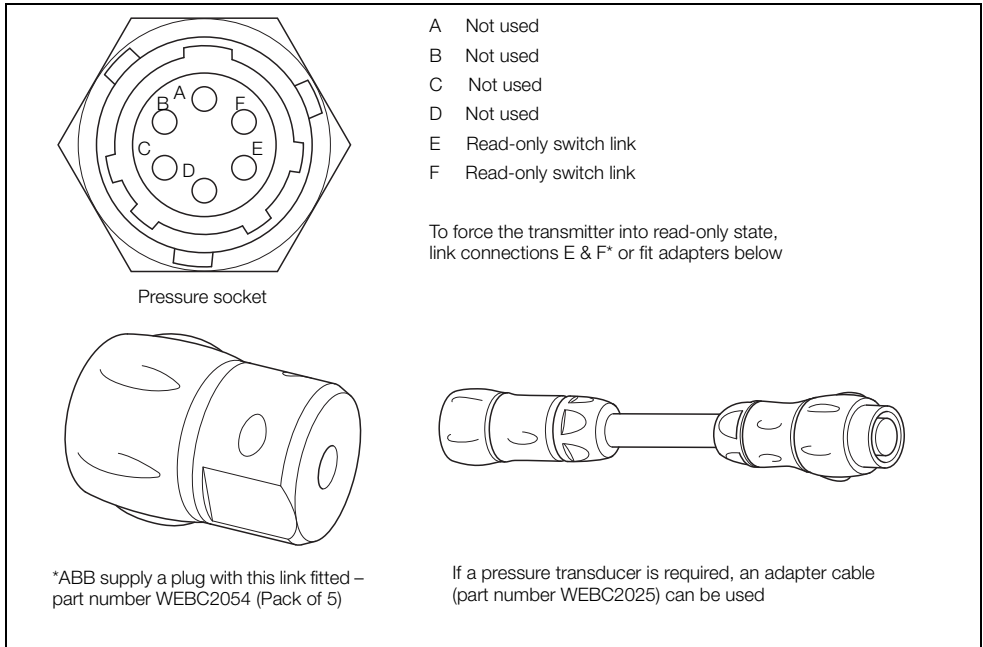

Fig. 3.13 Read-only Switch Connections

**Note.** For MID installations the meter must be ordered with the MID calibration option.

### 3.4 MODBUS Connection

This section describes the AquaMaster3 MODBUS serial data communications option and must be used in conjunction with:

- MODBUS Tables Supplement (COI/FET2XX/MOD/TBL-EN)
- Programming Guide (COI/FET2XX-EN)

Detailed specifications and recommendations for using and implementing MODBUS communications are contained in the following external publications:

- MODBUS over Serial Line – Specification and Implementation Guide V1.02. Dec 20, 2006. <http://www.modbus.org/>. Refer to this guide for hardware, cabling, grounding and shielding on MODBUS.
- MODBUS Application Protocol Specification V1.1b. Dec 28, 2006 – <http://www.modbus.org/>.

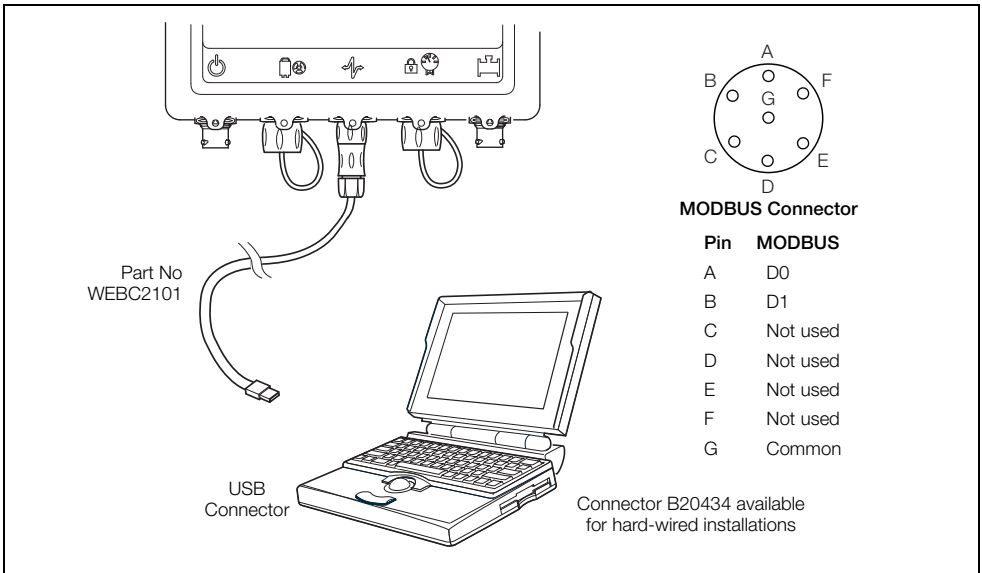

Fig. 3.14 MODBUS Connection

**Note.** A USB Comms lead driver is required when using WEBC2100 – download from [www.ftdichip.com/FTDrivers.htm](http://www.ftdichip.com/FTDrivers.htm)

### 3.4.1 2-wire Connection

AquaMaster3 MODBUS RS485 uses a 2-wire serial link in accordance with EIA/TIA-485 standard – see Fig. 3.15.

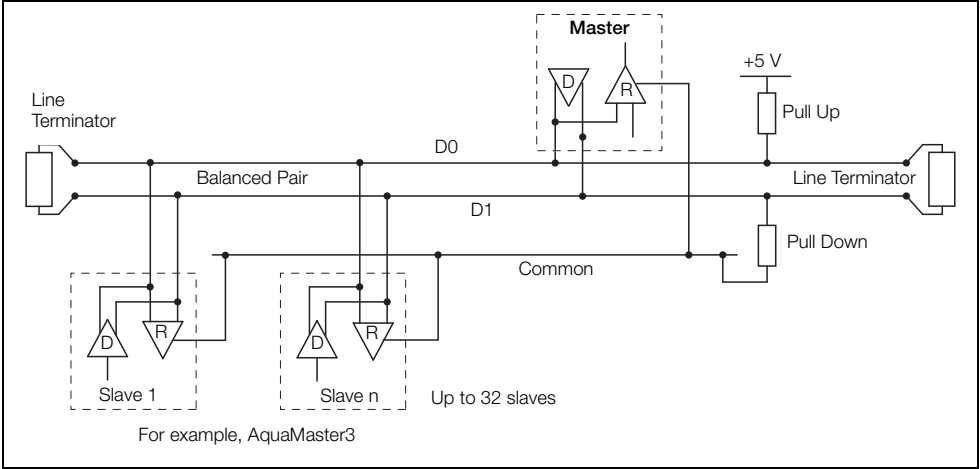

Fig. 3.15 General 2-Wire Topology

### 3.4.2 Host Computer Interface

An RS485 communications driver must be fitted to the host computer. It is strongly recommended that the interface has galvanic isolation to protect the computer from lightning damage and increase signal immunity to noise pick-up if the data is to be taken over long distances.

### 3.4.3 Pull-up and Pull-down Resistors / Polarization

To prevent false triggering of slaves when the master (host computer) is inactive, pull-up and pull-down resistors must be fitted to the RS485 interface at the host computer – see Fig. 3.16.

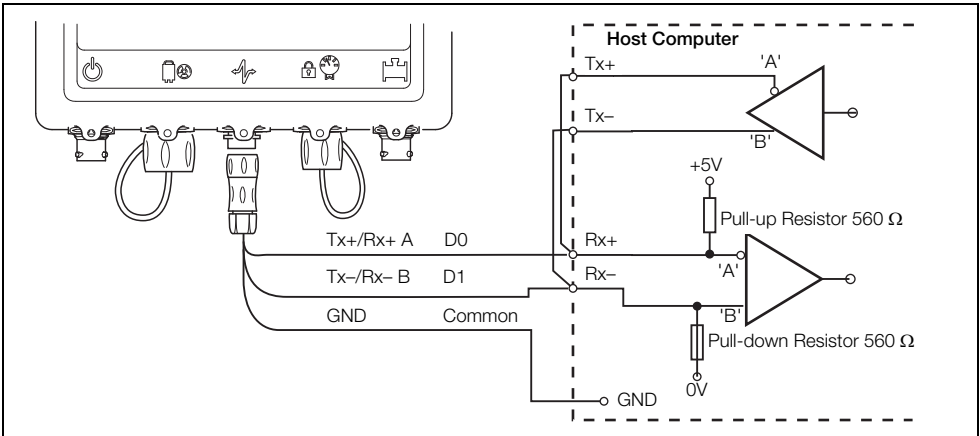

Fig. 3.16 Host Computer Interface

### 3.4.4 Termination Resistor

To minimize transmission line travelling wave reflections caused by impedance discontinuities at the end of the described RS485-cable a Line Termination is required near each of the 2 ends of the 'Bus' as described in the MODBUS over Serial Line – Specification and Implementation Guide V1.02 – see page 25.

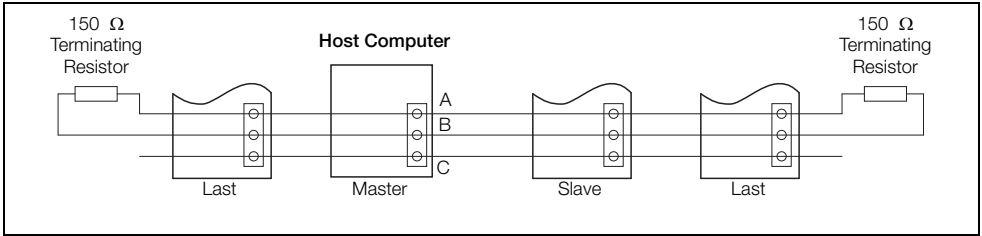

Fig. 3.17 Termination Resistor Location

### 3.4.5 Cable Properties

An RS485-MODBUS configuration without repeater has one trunk cable or 'Bus', along which devices are connected directly (daisy chaining) or by short 'tap' cables. The use of repeaters between several RS485-MODBUS is also possible.

The end-to-end length of the trunk cable must be limited. The maximum length depends on the Baud rate, the cable (gauge, capacitance or characteristic impedance), the number of loads on the daisy chain and the network configuration (2-wire or 4-wire).

For 9600 Baud rate and AWG26 (or wider) gauge, the maximum length is 1000 m (3280 ft.). Where 4-wire cabling is used as a 2-wire cabling system the maximum length must be divided by 2.

The 'tap' cables must be short and never more than 20 m (65.6 ft.). If a multi-port tap is used with n derivations, each one must have a maximum length of 40 m (131 ft.) divided by n.

The maximum serial data transmission line length for RS485 systems is 1200 m (3937 ft.). The lengths of cable that can be used are determined by the cable type, typically:

- Up to 6 m (19.7 ft.) – standard screened or twisted pair cable.
- Up to 300 m (984 ft.) – twin twisted pair with overall foil screen and an integral drain wire – for example, Belden 9502 or equivalent.
- Up to 1200 m (3937 ft.) – twin twisted pair with separate foil screens and integral drain wires – for example, Belden 9729 or equivalent.

Category 5 cables may be used for RS485-MODBUS to a maximum length of 600 m (1968 ft.).

For the balanced pairs used in an RS485-system, a characteristic impedance with value higher than 100  $\Omega$  is preferred, especially for 19200 and higher Baud rates.

### 3.5 Power Supply Connections

AquaMaster3 has 4 power supply options:

- Internal batteries (integral transmitters only) – see Section 3.5.1 (following)
- External battery pack – see Section 3.5.2, page 30
- Mains power – see Section 3.5.3, page 30
- Renewable energy – see Section 3.5.4, page 31

#### **Warning.**

- Disconnect the supply from any cables being terminated on the transmitter.
- Electrical installation and earthing (grounding) must be in accordance with relevant national and local standards.

**Note.** Power supply connections / earthing arrangements are identical for cathodically-protected remote transmitter systems. For cathodically-protected integral transmitter systems, follow cathodic installation practices.

#### 3.5.1 Fitting / Replacing Internal Batteries (Integral Transmitters Only)

#### **Caution.**

- Observe all warnings in Section 1.3.1, page 5.
- Never remove lid when water level around the flowmeter is close to enclosure lid.
- Use 3.6 V Lithium cells only
- Ensure correct polarity (all cells must face upwards)
- Do not mix old and new cells
- Use cells from a single manufacturer
- Use only batteries of the correct type, as listed in Appendix B.1, page 43.

Referring to Fig. 3.18:

1. Remove enclosure lid (A).
2. Remove and discard silica gel bag.
3. Disconnect battery connector (B).
4. Carefully remove battery pack (C) from enclosure.
5. Carefully remove 3 cells (D) in turn from the top level of the pack.
6. Carefully remove 3 cells (E) in turn from the bottom level of the pack.
7. Fit 3 new cells to the bottom level of the pack, ensuring the correct polarity, as shown in Fig. 3.18, page 29.
8. Fit 3 new cells to the top level of the pack.
9. Carefully refit battery pack (C) to enclosure.
10. Reconnect battery connector (B).
11. Place new silica gel bag on top of battery pack.
12. Ensuring O-ring seal and O-ring groove is clean, refit enclosure lid (A) and tighten finger-tight.

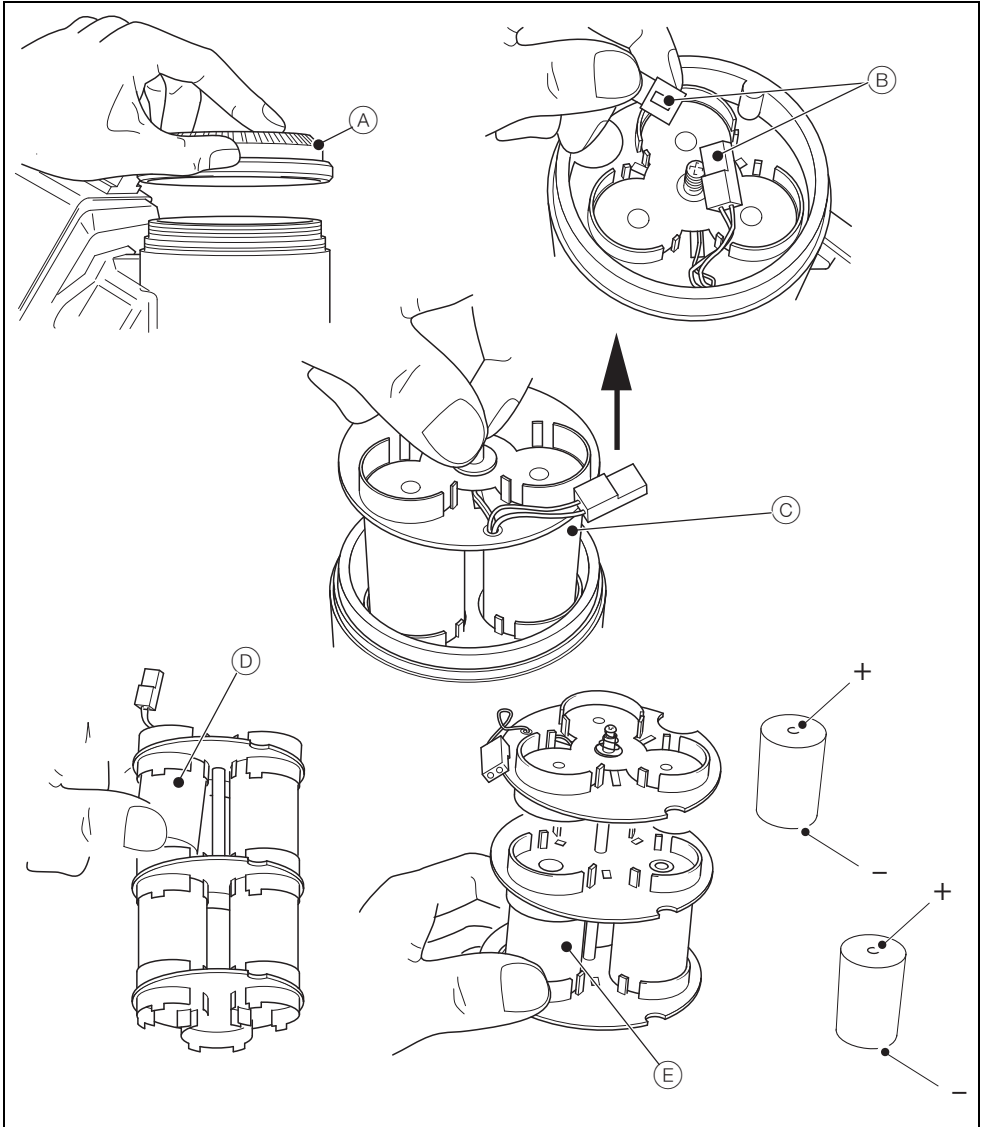

Fig. 3.18 Internal Battery Pack (Integral Transmitters Only)

### 3.5.2 External Battery Power Supply

**Note.** Before making connections, check the Data label to confirm power supply requirements. AquaMaster3 can be powered from Explorer-style battery packs fitted with the MIL plastic style plug. The Explorer battery capacity is  $\frac{6}{7}$  of published life.

AquaMaster3 can be supplied with an optional battery pack.

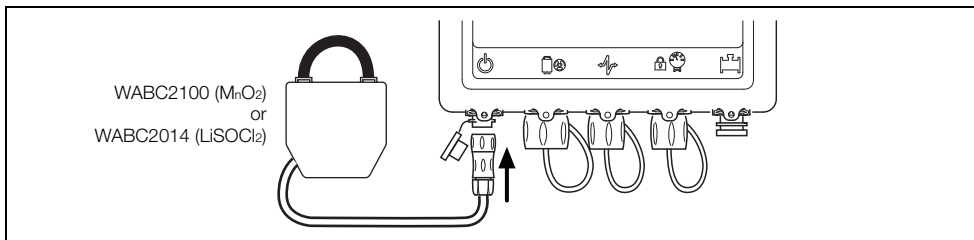

Fig. 3.19 Connecting a Battery Supply

### 3.5.3 Mains Power Supply

**Note.** Before making connections, check the Data label to confirm power supply requirements.

Mains power requirements:

- 110 to 240 V AC, 50 / 60 Hz @ <3 VA
- Cable length 3 m (9.8 ft.)
- Protected by a fused isolator, rating – mains, anti-surge 3 A.

Make connections as shown in Fig. 3.20.

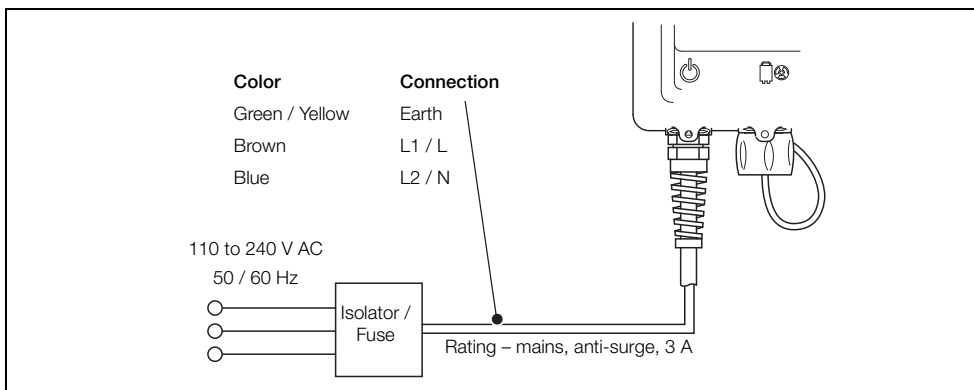

Fig. 3.20 Connecting a Mains Power Supply



### 3.5.4 Renewable Energy Supply

**Note.**

- Before making connections, check the Data label to confirm power supply requirements.
- An output regulator can be omitted if the off load-voltage is below V in max.
- Renewable energy generators do not operate at maximum capacity, for example, low wind speeds, coating of the solar panel with dust and wildlife droppings and short daylight periods in winter. For these reasons, in some installations, generators with a capacity greater than the specified 5 W minimum should be used. Contact ABB for a technical note, giving guidance on the selection of suitably sized generators for AquaMaster3.

Renewable energy supply requirements:

- Input 12 V (nominal)
- V in max. 22 V DC
- V in min. 6 V DC
- Solar panel or wind generator 5 W or greater

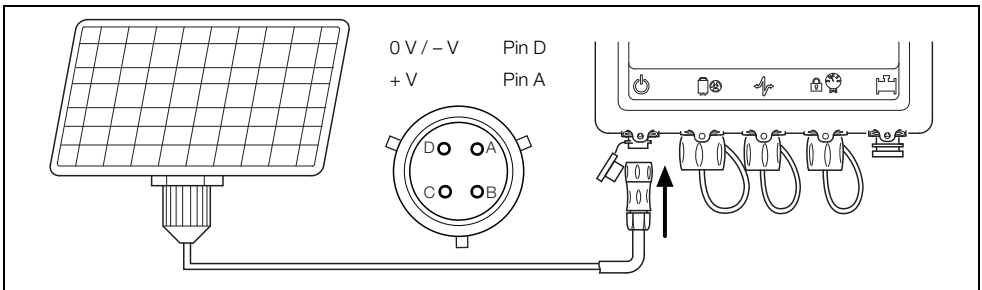

Fig. 3.21 Connecting a Renewable Energy Supply

## 4 Start-Up and Operation

### **Warning.**

- Observe all battery and other warnings in Section 1.3, page 4.
- Operation at extremes of temperature significantly shortens the battery capacity and life – see Specification, page 37.

### 4.1 Start-up

To start the AquaMaster3 for the first time:

1. Connect the external power source; mains / battery or renewable power source – see Section 3.5, page 28.
2. Remove transportation label.
3. Cover the display area for a few seconds.
4. Uncover the display area. The display is activated, the AquaMaster3 performs a self-test and begins communication with the sensor.

A successful connection is indicated by the message 'Pass' in the display window and normal flowmeter operation commences.

### **Notes.**

- If the display shows 'Err 1', check the sensor wiring. If the fault is rectified, the transmitter restarts automatically.
- If the display shows 'Err 2' or 'Err 3', contact ABB.

## 4.2 Display Activation

To activate the display during normal operation:

1. Cover the display area for a few seconds.
2. Uncover the display area. The display is activated and the AquaMaster3 cycles through the programmed set of display measurements.

**Note.** To use local or remote serial communications, for instructions on how to alter the displayed set of measurements and for meter setup, refer to COI/FET2XX-EN.

## 4.3 Display Information

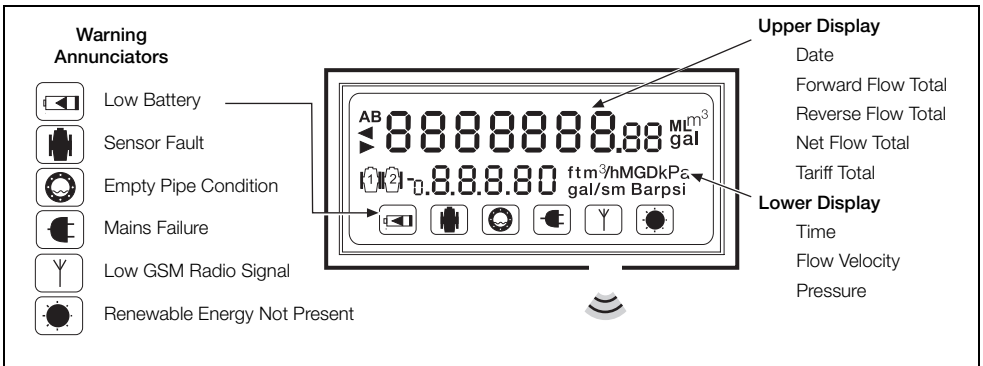

Fig. 4.1 AquaMaster3 Display Information

## 4.4 Servicing Plugs and Sockets

To ensure long and reliable service life for the plugs and sockets on AquaMaster3 Flow Transmitters, ABB recommend regular treatment of the gold connector pins.

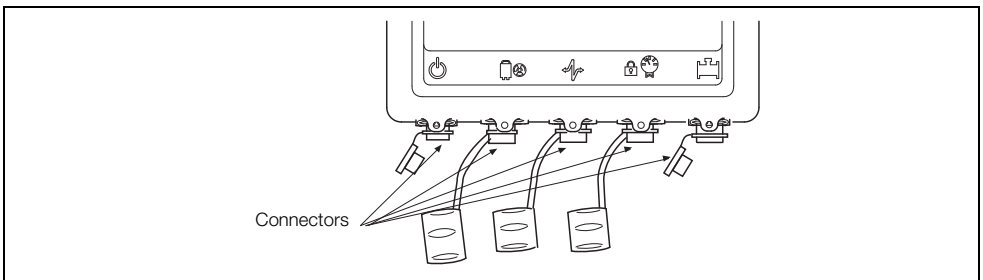

Fig. 4.2 Transmitter Sockets (MIL Style)

### 4.4.1 Service Intervals

Treat all connectors:

- at 3-year intervals
- when the battery pack is changed
- when the installation is visited for other reasons (such as CalMaster 2 Verification)

#### 4.4.2 Equipment Required

Cleaners are available from your local ABB representative. To purchase supplies directly or for local distributor details please go to the following website:

<http://store.caig.com/>

Material details are:

Description	Part No.
DeoxIT® – Contact Cleaner & Rejuvenator DeoxIT® – Mini-spray, 5 % solution, flushing action, 14 g (Applications = 150 approx.)	D5MS–15
DeoxIT® GOLD – Contact Enhancer, conditioner & Protector DeoxIT® GOLD G5 Mini Spray 5 % solution, 14 g, flushing action and safe on plastics (Applications = 150 approx.)	G5MS–S

#### 4.4.3 Preparation

Item	Precaution
Real-time Clock	This procedure may result in the loss of the real-time clock. Once the treatment is complete, check, and if necessary, re-program the real-time clock and date – see Section 4.4.8, page 36.
Transmitters with Data Loggers	This procedure may result in the loss of logger contents on transmitters fitted with data loggers. To prevent data loss, download logger data before treating the connector pins.

#### 4.4.4 Disconnection

Before DeoxIT treatment, disconnect ALL cables in the following order:

1. Battery pack / power
2. Sensor
3. Pressure transducer (if fitted)
4. Outputs
5. Communications cable (if connected)

Uncap unused connectors.

#### 4.4.5 Order of Treatment

To minimize disruptive effects of repeatedly breaking and making connections perform the following order of treatment using the Stage 1 and Stage 2 processes for each plug and socket in turn:

1. Treat sensor connector and cable (ensure battery is disconnected at this point).
2. Treat battery connector and cable (ensure sensor is disconnected at this point).
3. Treat all other peripheral connections and cables.

#### 4.4.6 Stage 1 – Oxide Removal and Cleaning

To remove existing oxide and clean the pins:

1. Apply a short burst (around 0.5 second duration) of DeoxIT DN5 spray to the metal surfaces of the connectors and to the gold connector pins.

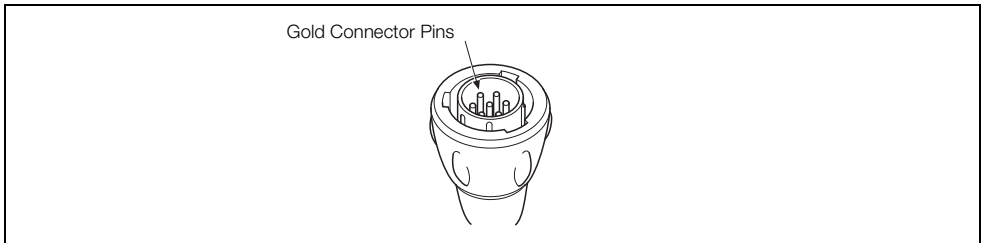

*Fig. 4.3 Cleaning the Gold Connector Pins*

2. Connect a corresponding male / female connector to the connector under test 5 times.
3. Wait 10 seconds.
4. Reapply one short burst (around 0.5 s duration) of DeoxIT DN5 spray to the metal surfaces.
5. Allow any residue to run out of connector.
6. Wait 30 seconds for the application to dry.

**Note.** The surfaces may not appear completely dry after this time as a protective layer is left behind when the carrier evaporates.

#### 4.4.7 Stage 2 – Oxide Prevention

To prevent oxide build-up:

1. Apply a very short burst (not more than 0.5 seconds duration) of DeoxIT Gold GN5 spray to the metal surfaces.  
Avoid unnecessary spraying onto transmitter housing.
2. Wait 10 seconds.
3. Reapply one very short burst (not more than 0.5 seconds duration) of DeoxIT Gold GN5 spray to the metal surfaces.
4. Allow any residue to run out of connector.
5. Wait 30 seconds for the application to dry.

**Note.** The surfaces may not appear completely dry after this time as a protective layer is left behind when the carrier evaporates.

#### 4.4.8 Completion tasks

To complete servicing of the plugs and sockets:

1. Reconnect peripheral devices in this order.
  - a. Sensor
  - b. Pressure transducer (if fitted)
  - c. Outputs
  - d. Communications
  - e. Battery pack / power
2. Refit protective caps on unused connection sockets.
3. For transmitters with built-in loggers and no GSM, re-program the real-time clock and date – see Programming Guide (COI/FET2XX-EN).

## 5 Specification

### AquaMaster3 transmitter

#### Mounting

Integral with sensor (integral-mount)

or

Remote up to 200 m (650 ft.)

#### Housing

IP68 (NEMA 6P), <2 m (6 ft.)

Stainless steel housing in a thermoplastic outer cover with window, encapsulated with polyurethane-based resin.

#### Electrical connections

IP68 plug and socket, mains cable

#### Sensor cable

ABB cable supplied as standard

SWA cable available (via adaptor box) on application

#### Mains supply

85 to 265 V AC @ <3 VA

Connection cable: approx. 3 m (10 ft.)

Mains power failure backup time: Standard, approx. 5 days from internal super capacitor.

Optional, up to 5 years with power cable option AS and external battery option AD.

#### Renewable power

Solar or wind

Input voltage: 6 to 22 V DC @ <5 W

**Note.** Renewable energy generators do not operate at maximum capacity, for example, low wind speed, coating of the solar panel, short daylight periods. As a consequence, some installations require generators with a capacity greater than the specified 5 W minimum.

Max. current: 200 mA

Backup power time up to 3 weeks  
(dependent on operating conditions)

## External battery pack

IP68 (NEMA 6P)

### Standard

Manganese alkaline battery pack with nominal 5-year operational life @ 0 to 45 °C (32 to 113 °F) \*

### Optional

Lithium thionyl chloride 9-cell battery pack with nominal 10-year life \*

Lithium thionyl chloride 4-cell battery pack with nominal 5-year life \*

## Internal battery (integral-mount version only)

IP68 (NEMA 6P) sensor integral housing

### Standard

Lithium thionyl chloride 3.6 V D-cell (x 6) with nominal 6-year operational life @ -20 to 60 °C (-4 to 140 °F) \*

Suitable batteries, non-solder tag (not supplied):

- SAFT LS36600 / Tadiran TL-5930 / Varta ER D / Tekcell SB-D02

## Battery changeover backup time

Approximately 2 minutes

## Pulse and alarm outputs

Three, bidirectional, solid-state switches with common isolation

±35 V DC 50mA

Output 1 – forward only or forward plus reverse pulses

Output 2 – reverse pulses or direction indicator

Output 3 – alarm indicates any problem with measurement or with power

Pulse output – 50 Hz maximum, 50 % nominal duty cycle

## Communications options

Serial data communications

Local Port RS232

**Note.** On battery and renewable energy versions frequent use of the RS232 or RS485 port considerably reduces battery / standby life.

RS485 MODBUS

MODBUS RTU slave

Baud rates:

1200, 2400, 4800, 9600 or 19200

RS485:

2-wire + ground signalling

Low power shut-off mode after 10 s of inactivity

\* Battery life is shorter with GSM, depending on how frequently it is used and for what period. For example, used once per day for SMS automated reporting of data logged at 15 minute intervals, the life of a battery pack would be typically reduced by 5 %. Battery life is shorter at extremes of temperature.

Battery life of the FEV DN200 is 50% of typical life.

Battery life of the WITS GPRS version depends on the configured connection schedule.



## **Encoder interface / scancode / scanreader (non-logging versions only)**

Function – remote reading of totalizer and serial number

- Connections
  - 2-wire for inductive pads (max. cable length 80 m [260 ft])
  - 3-wire for AMR
  
- Compatible readers
  - Severn Trent Services Smart reader
  - ABB or Elster SR100 and SR50
  - Logicon Versaprobe
  - Itron ERT
  
- Compatible inductive pads
  - Starpad

---

## **Telemetry applications (option)**

### **GSM / SMS modem**

Mounting:

Internal

Frequency bands:

Quad band: 850 / 900 / 1800 / 1900 MHz

Functions:

SMS auto report of flow and optionally, pressure logger data (typically 1 s or 1 min. average)

SMS report frequency: typically daily

SMS alarm reporting at time of event, for example power loss, limited to 1 per day

SMS flowmeter configuration

SMS flowmeter diagnosis

SMS total / tariff auto report

WITS / DNP3 version 1.1, 1.2 and 1.3 via TCP/IP GPRS

### **GSM antenna (option)**

Quad band operation:

850 / 900 / 1800 / 1900 MHz

Mounting:

Integral with transmitter or remote.

Antenna environmental:

IP66 (NEMA4) waterproof for accidental submersion

**Note.** The GSM does not operate with integral antenna under water.

General advice is to mount the antenna as high as possible, always outside of any metal enclosure and not under the surface of the ground.

## Temperature ranges

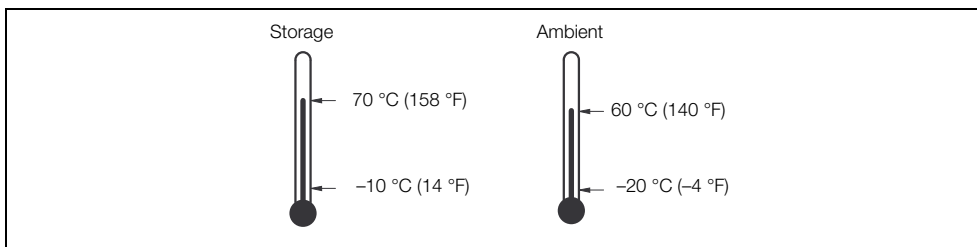

Battery capacity and life are shortened when operating outside the temperature range:

Manganese Alkaline 0 to 45 °C (32 to 113 °F)

Lithium Thionyl Chloride 0 to 60 °C (32 to 140 °F)

---

## Response time (programmable)

### Minimum

1 s (mains-powered)

15 s (battery-powered + external renewable energy)

---

## Device languages

English, French, German, Spanish, Italian, Dutch  
(English-only for the WITS version.)

---

## Pressure system – external transducer (option)

### Pressure range

16 bar Abs.

### Connection

Standard quick-fit male probe connector via an adapter cable

### Operating temperature range

-20 (ambient) to 70 °C (-4 to 158 °F)

Protect the sample and transducer from freezing.

### Accuracy (typical)

±0.4 % of range

### Thermal error band (typically 100 °C [212 °F])

±1.5 % span

### Cable length

5, 10 or 20 m (16, 33 or 66 ft.)

### Logger details (option)

	Logger		
	1	2	3
<b>Logger Function</b>	<b>Flow &amp; Pressure</b>	<b>Flow &amp; Pressure</b>	<b>Forward, Reverse, Tariffs &amp; Net Flow Totals</b>
No. of Records	8831	11361	732
Logging Interval	15 to 65500 s (adjustable)		24 hr (fixed)
Typical Capacity	3 months @15 minutes	7 days (approx.) @ 1 minutes	2 years

	WITS Logger		
	High Speed Sample Data	Archive Log	
<b>Logger Function</b>	<b>Flow &amp; Pressure</b>	<b>Flow &amp; Pressure</b>	<b>Logger Capacity</b>
Logging Interval	60 seconds 90 seconds 180 seconds	15 minutes (configurable)	20.67 days 31 days 62 days

### Software availability

Software	Direct RS232	SMS (Text)
ABB AC800M	✘	✓
ABB Generic (for example, LogMaster)	✓	✘
Areal (Topkapi)	✘	✓
MasterVue (I&P AutoChart)	✘	✓
EcoTech	✘	✓
HydroComp	✘	✓
Mobile phone text	✘	✓
OSI PI Database or Capula	✓	✘
QTech	✘	✓
Zeepaard	✘	✓
Agua Ambiente Servicios Integrales SA	✘	✓

DS/FER200/FEF200/FEV200-EN Rev. O

## **Appendix A – GSM-Equipped Units, Safety Precautions**

The following safety precautions must be observed during all phases of the operation, usage, service or repair of this GSM cellular terminal. Failure to comply with these precautions violates safety standards of design, manufacture and intended use of the product. The Company assumes no liability for customer failure to comply with these precautions.

1. When in a hospital or other health care facility, observe the restrictions on the use of mobiles. Switch the cellular terminal or mobile off, if instructed to do so by the guidelines posted in sensitive areas. Medical equipment may be sensitive to RF energy. The operation of cardiac pacemakers, other implanted medical equipment and hearing aids can be affected by interference from cellular terminals or mobiles placed close to the device. If in doubt about potential danger, contact the physician or the manufacturer of the device to verify that the equipment is shielded properly. Pacemaker patients are advised to keep their hand-held mobile away from the pacemaker, while the mobile is on.
2. Switch off the cellular terminal or mobile before boarding an aircraft. Remove the SIM card before shipping. Make sure it cannot be switched on inadvertently. The operation of wireless appliances in an aircraft is forbidden to prevent interference with communications systems. Failure to observe these instructions may lead to the suspension or denial of cellular services to the offender, legal action, or both.
3. Do not operate the cellular terminal or mobile in the presence of flammable gases or fumes. Switch off the cellular terminal when you are near petrol stations, fuel depots, chemical plants or where blasting operations are in progress. Operation of any electrical equipment in potentially explosive atmospheres can constitute a safety hazard.
4. Your cellular terminal or mobile receives and transmits radio frequency energy while switched on. Remember that interference can occur if it is used close to TV sets, radios, computers or inadequately shielded equipment. Follow any special regulations and always switch off the cellular terminal or mobile wherever forbidden when you suspect that it may cause interference or danger.

**Note.** Cellular terminals or mobiles operate using radio signals and cellular networks cannot be guaranteed to connect in all conditions. Therefore, you should never rely solely upon any wireless device for essential communications, for example emergency calls.

To make or receive calls, the cellular terminal or mobile must be switched on and in a service area with adequate cellular signal strength.

## Appendix B Accessories / Spares Kits

### B.1 Common accessories

MREX9969	Close-coupled mounting kit
WEBC2003/10	Remote GSM aerial kit 10 m (32 ft.)
WEBC2110/01 WEBC2110/05 WEBC2110/10	AquaMaster 3 Remote GSM quad band aerial kit: 1m (3.3 ft.) 5m (16.4 ft.) 10m (32 ft.)
B20433 B20434	MIL connector: 4-pin MIL – renewable power connector 7-pin MIL – RS485 MODBUS and RS232 connector
WABC2100 WABC2101 WABC2102 MEBX2110 Integral battery type	Batteries / spares Remote battery pack ( $MnO_2$ ) Remote battery pack ( $LiSOCl_2$ ) – 4 cell Remote battery pack ( $LiSOCl_2$ ) – 9 cell Integral battery carrier assembly (replacement spare) 3.6 V Lithium Thionyl Chloride, size D Recommended manufacturer part numbers: SAFT LS 33600 / Tadiran TL-5930 / Varta ERD / Tekcell SB-D02
WABC2010 WABC2010/01 WABC2010/05 WABC2010/10 WABC2010/20 WABC2010/30 WABC2010/40 WABC2010/50 WABC2010/60 WABC2010/70 WABC2010/80	Sensor cable assembly: 0.5 m (1.6 ft.), for integral / close-coupled 1 m (3.3 ft.), for remote 5 m (16.4 ft.), for remote 10 m (32.8 ft.), for remote 20 m (65.6 ft.), for remote 30 m (98.4 ft.), for remote 40 m (131.2 ft.), for remote 50 m (164.0 ft.), for remote 60 m (196.8 ft.), for remote 70 m (229.6 ft.), for remote 80 m (262.4 ft.), for remote
WABC2010/01 WEBC2011/M WEBC2012/M WEBC2013/M WEBC2014/M WEBC2006/M	Output cable: 1 m (3.3 ft.) wire-ended for Technolog Cello (MIL) for Technolog Cello (Brad Harrision) for RADCOM Multilog for Primayer Xilog 2x19-way MIL
WEBC2024	Connector security plug – pack of 5
WEBC2100 WEBC2101	Communication cable: RS232 to USB RS485 to USB
WABX2000/05 WABX2000/10	Pressure cable assembly: 16 bar (232 psi), 5 m (16.4 ft.) 16 bar (232 psi), 10 m (32.8 ft.)

## B.2 Adapter Cable / Upgrade Kits

WABC2036	Pressure adapter kit: M16 Plastic to MIL
WABC2022/M WABC2023/M	Sensor upgrade kit: M20 Plastic to MIL M20 Armored to MIL
WABC2035 WABC2024/M WABC2025/M WABC2026/M	Sensor adaptor kit: M16 Plastic to MIL M20 Plastic to MIL M20 Armored to MIL ½ in. NPT blanked to MIL
WABC2104/05 WABC2104/10 WABC2104/20 WABC2104/30	Scanreader cable assembly: 5 m (16.4 ft.) 10 m (32.8 ft.) 20 m (65.6 ft.) 30 m (98.4 ft.)

# Products and customer support

## Automation Systems

For the following industries:

- Chemical & Pharmaceutical
- Food & Beverage
- Manufacturing
- Metals and Minerals
- Oil, Gas & Petrochemical
- Pulp and Paper

## Drives and Motors

- AC and 6 Drives, AC and DC Machines, AC Motors to 1kV
- Drive Systems
- Force Measurement
- Servo Drives

## Controllers & Recorders

- Single and Multi-loop Controllers
- Circular Chart and Strip Chart Recorders
- Paperless Recorders
- Process Indicators

## Flexible Automation

- Industrial Robots and Robot Systems

## Flow Measurement

- Electromagnetic Flowmeters
- Mass Flowmeters
- Turbine Flowmeters
- Wedge Flow Elements

## Marine Systems & Turbochargers

- Electrical Systems
- Marine Equipment
- Offshore Retrofit and Refurbishment

## Process Analytics

- Process Gas Analysis
- Systems Integration

## Transmitters

- Pressure
- Temperature
- Level
- Interface Modules

## Valves, Actuators and Positioners

- Control Valves
- Actuators
- Positioners

## Water, Gas & Industrial Analytics Instrumentation

- pH, Conductivity and Dissolved Oxygen Transmitters and Sensors
- Ammonia, Nitrate, Phosphate, Silica, Sodium, Chloride, Fluoride, Dissolved Oxygen and Hydrazine Analyzers
- Zirconia Oxygen Analyzers, Katharometers, Hydrogen Purity and Purge-gas Monitors, Thermal Conductivity

## Customer support

We provide a comprehensive after sales service via a Worldwide Service Organization. Contact one of the following offices for details on your nearest Service and Repair Centre.

### UK

ABB Limited  
Tel: +44 (0)1453 826661  
Fax: +44 (0)1453 829671

### USA

ABB Inc.  
Tel: +1 215 674 6000  
Fax: +1 215 674 7183

### Client Warranty

Prior to installation, the equipment referred to in this manual must be stored in a clean, dry environment, in accordance with the Company's published specification.

Periodic checks must be made on the equipment's condition. In the event of a failure under warranty, the following documentation must be provided as substantiation:

- A listing evidencing process operation and alarm logs at time of failure.
- Copies of all storage, installation, operating and maintenance records relating to the alleged faulty unit.

## **ABB Limited**

### **Process Automation**

Oldends Lane  
Stonehouse  
Gloucestershire GL10 3TA  
UK

Tel: +44 1453 826 661

Fax: +44 1453 829 671

## **ABB Inc.**

### **Process Automation**

125 E. County Line Road  
Warminster  
PA 18974  
USA

Tel: +1 215 674 6000

Fax: +1 215 674 7183

**[www.abb.com](http://www.abb.com)**

#### Note

We reserve the right to make technical changes or modify the contents of this document without prior notice. With regard to purchase orders, the agreed particulars shall prevail. ABB does not accept any responsibility whatsoever for potential errors or possible lack of information in this document.

We reserve all rights in this document and in the subject matter and illustrations contained therein. Any reproduction, disclosure to third parties or utilization of its contents – in whole or in parts – is forbidden without prior written consent of ABB.

Copyright© 2016 ABB

All rights reserved

3KXF208204R4201

Capula© is a copyright of Capula Limited 2010.

EcoTech™ is a registered trademark of EcoTech Pty Ltd.

HydroComp is a copyright of HydroComp Inc 2010.

Microsoft Excel™ and Windows™ are registered trademarks of the Microsoft Corp. MeterVue© is a copyright of Information and Performance Services (I&P).

MODBUS™ is a registered trademark of MODBUS corporation.

OSI™ is a registered trademarks of WADIS.

PMAC™ is a registered trademark of Technolog.

Primeware™ and Xilog™ are registered trademarks of Primayer.

QTech™ is a registered trademark of QTech Data Systems Limited.

Topkapi™ is a registered trademark of AREAL.

Vodafone PAKNET™ and Vodafone Radiopad™ are registered trademarks of Vodafone.

Zeepaard is a copyright of Zeepaard Engineering Sdn.Bhd.