

Temperature sensors SensyTemp TSP

Measuring insets TSA

Measurement made easy



Short product description

Temperature sensors SensyTemp TSP with measuring insets TSA for temperature measurement with resistance thermometers and thermocouples in the various process applications.

Further information

Additional documentation on Temperature sensors SensyTemp TSP and the measuring inset TSA is available for download free of charge at www.abb.com/temperature.
Alternatively simply scan this code:



Manufacturer

ABB Automation Products GmbH

Process Automation

Schillerstr. 72

32425 Minden

Germany

Tel: +49 571 830-0

Fax: +49 571 830-1806

Customer service center

Tel: +49 180 5 222 580

Mail: automation.service@de.abb.com

Contents

1	Safety.....	4	8	Commissioning.....	24
1.1	General information and instructions	4	8.1	General remarks	24
1.2	Warnings	4	8.2	Checks prior to commissioning	24
1.3	Intended use.....	4	9	Operation.....	24
1.4	Improper use	5	9.1	Safety instructions.....	24
1.5	Warranty provisions	5	9.2	Menu navigation	24
2	Use in potentially explosive atmospheres in accordance with ATEX	5	9.3	Operating button functions.....	25
2.1	General remarks	5	9.3.1	Process display.....	25
2.2	Ex relevant specifications	5	9.3.2	Menu structure and diagnostic messages	26
2.2.1	Approvals	5	9.3.3	Setting the language	26
2.2.2	Conditions for the use in potentially explosive areas	6	10	Diagnosis / error messages	27
2.2.3	Intrinsic safety ATEX "Ex i"	6	10.1	Error messages.....	27
2.2.4	Flameproof enclosure "Ex d"	7	10.2	Faults in operation.....	27
2.2.5	Dust explosion protection (enclosure).....	7	10.2.1	Specific faults with thermocouples	28
2.2.6	Non-sparking and dust explosion protection	9	10.2.2	Specific faults with resistance thermometers	28
2.3	Installation instructions.....	9	11	Repair	29
2.3.1	Cable entries	9	11.1	Returning devices	29
2.4	Electrical connections	12	12	Recycling and disposal.....	29
2.4.1	Installation in potentially explosive areas without integrated transmitter.....	12	12.1	Disposal.....	29
2.4.2	Installation in potentially explosive areas with integrated transmitter.....	14	12.2	Information on ROHS Directive 2011/65/EC.....	29
2.5	Commissioning.....	16	13	Spare parts, consumables and accessories	30
2.6	Operating instructions.....	16	14	Specifications.....	30
2.6.1	Protection against electrostatic discharges	16	15	Declaration of conformity	30
3	Function and system design.....	17	16	Appendix	31
4	Product identification.....	18	16.1	Return form	31
4.1	Name plate.....	18			
5	Functional safety (SIL).....	19			
6	Transport and storage	20			
6.1	Inspection.....	20			
6.2	Transporting the device	20			
7	Installation	20			
7.1	General information.....	20			
7.2	Cable glands	20			
7.2.1	Prerequisites for achieving the IP protection class21				
7.3	Installation instructions.....	21			
7.3.1	Recommended installation length	21			
7.4	Insufficient nominal diameter	21			
7.5	Electrical connections	22			
7.5.1	Safety instructions for electrical installation	22			
7.5.2	General information.....	22			
7.5.3	Electrical connections	22			
7.5.4	Harting plug connection in connection head.....	23			

1 Safety

1.1 General information and instructions

These instructions are an important part of the product and must be retained for future reference.

Installation, commissioning, and maintenance of the product may only be performed by trained specialist personnel who have been authorized by the plant operator accordingly. The specialist personnel must have read and understood the manual and must comply with its instructions.

For additional information or if specific problems occur that are not discussed in these instructions, contact the manufacturer.

The content of these instructions is neither part of nor an amendment to any previous or existing agreement, promise or legal relationship.

Modifications and repairs to the product may only be performed if expressly permitted by these instructions.

Information and symbols on the product must be observed.

These may not be removed and must be fully legible at all times.

The operating company must strictly observe the applicable national regulations relating to the installation, function testing, repair and maintenance of electrical products.

1.2 Warnings

The warnings in these instructions are structured as follows:

DANGER

The signal word "DANGER" indicates an imminent danger. Failure to observe this information will result in death or severe injury.

WARNING

The signal word "WARNING" indicates an imminent danger. Failure to observe this information may result in death or severe injury.

CAUTION

The signal word "CAUTION" indicates an imminent danger. Failure to observe this information may result in minor or moderate injury.

NOTICE

The signal word "NOTICE" indicates useful or important information about the product.

The signal word "NOTICE" is not a signal word indicating a danger to personnel. The signal word "NOTICE" can also refer to material damage.

1.3 Intended use

The temperature sensors are used for measuring temperatures in a vast range of process applications.

The device is designed for use exclusively within the values stated on the name plate and in the technical specifications (see the "Specifications" chapter in the operating instructions or the data sheet).

- The maximum operating temperature must not be exceeded.
- The permissible ambient temperature must not be exceeded.
- The degree of protection must be observed.

Prior to using the devices with corrosive or abrasive media, the operator must check the level of resistance of all process-wetted parts. ABB Automation Products GmbH will gladly support you in selecting the appropriate device, but cannot accept any liability in doing so.

The device has been designed for use exclusively within the technical limit values indicated on the identification plate and in the data sheets.

When using media for measurement the following points must be observed:

- Measuring media may only be used if, based on the state of the art or the operating experience of the user, it can be assured that the chemical and physical properties necessary for safe operation of the materials of temperature sensor components coming into contact with these will not be adversely affected during the operating period.
- Media containing chloride in particular can cause corrosion damage to stainless steels which, although not visible externally, can damage wetted parts beyond repair and lead to the measuring medium escaping. It is the operator's responsibility to check the suitability of these materials for the respective application.
- Measuring media with unknown properties or abrasive measuring media may only be used if the operator can perform regular and suitable tests to ensure the safe condition of the meter.

1.4 Improper use

The following are considered to be instances of improper use of the device:

- For use as a climbing aid, e.g. for mounting purposes.
- For use as a support for external loads, e.g. as a support for piping, etc.
- Material application, e.g. by painting over the name plate or welding/soldering on parts.
- Material removal, e.g. by spot drilling the housing.

1.5 Warranty provisions

Using the device in a manner that does not fall within the scope of its intended use, disregarding this manual, using underqualified personnel, or making unauthorized alterations releases the manufacturer from liability for any resulting damage. This renders the manufacturer's warranty null and void.

2 Use in potentially explosive atmospheres in accordance with ATEX

2.1 General remarks

Special regulations must be observed in potentially explosive atmospheres as regards the power supply, signal inputs / outputs and ground connections. The information relating specifically to explosion protection that is presented in the individual chapters must be observed.

All parts must be installed in accordance with the manufacturer's specifications, as well as relevant standards and regulations.

To ensure commissioning and safe operation, the respectively applicable requirements must be met especially for the protection of workers.

IP protection class

The connection parts of the temperature sensor must be installed in such a way that at least the IP protection class of the explosion protection class used can be achieved.

Temperature classes

The temperature sensors are marked with the T6 temperature class. If the existing explosive gas atmosphere is to be assigned a temperature class of T5, T4, T3, T2, or T1, the temperature sensors can be used at higher process temperatures according to the specifications of temperature class.

2.2 Ex relevant specifications

2.2.1 Approvals

TSP temperature sensors are approved for a variety of approvals.

These range from metrological approvals through Ex approvals for individual countries, ATEX certificates applicable across EU and in Switzerland up to internationally recognized IECEx documents.

Specifically, these are:

- ATEX Ex i PTB 01 ATEX 2200 X
- ATEX Ex d PTB 99 ATEX 1144
(only TSP3X1)
- Dust explosion BVS 06 ATEX E 029
 protection
(only TSP3X1)
- Ex n Declarations of conformity
(Zone 2 and 22)
- IECEx
- GOST / EAC Ex

2.2.2 Conditions for the use in potentially explosive areas

The operator assumes responsibility for the proper installation according to the valid approval conditions when replacing the measuring inset in a thermometer. It is necessary to specify the production no. marked on the old part to ABB, so that ABB can examine the conformity of the ordered execution with the first delivery and the applicable approval.

Thermal resistance

The following table lists thermal resistances for measuring insets in diameter < 6.0 mm (0.24 inch) and ≥ 6.0 mm (0.24 inch). The values have been specified subject to the conditions "Gas with a flow velocity of 0 m/s" and "Measuring inset without or with an additional thermowell".

Thermal resistance R_{th} $\Delta t = 200 \text{ K/W} \times 0.038 \text{ W} = 7.6 \text{ K}$	Measuring inset $\varnothing < 6 \text{ mm}$ (0.24 inch)	Measuring inset $\varnothing \geq 6 \text{ mm}$ (0.24 inch)
Without thermowell		
Resistance thermometer	200 K/W	84 K/W
Thermocouple	30 K/W	30 K/W
With thermowell		
Resistance thermometer	70 K/W	40 K/W
Thermocouple	30 K/W	30 K/W

K/W = kelvin per watt

Temperature rise in the event of a fault

In the event of a fault, the temperature sensors will exhibit a temperature rise Δt as appropriate for the applied power. This Δt temperature rise must be taken into account with regard to the difference between process temperature and temperature class.

NOTICE

In the event of a fault (short-circuit), the dynamic short-circuit current that occurs in the measurement circuit for a matter of milliseconds is not relevant with regard to temperature rise.

The Δt temperature rise can be calculated using the following formula: $\Delta t = R_{th} \times P_o$ [K/W x W]

- Δt = Temperature rise
- R_{th} = Thermal resistance
- P_o = Output power of an additional connected transmitter

Example:

Resistance thermometer diameter 3 mm (0.12 inch) without thermowell:

$$R_{th} = 200 \text{ K/W},$$

Temperature transmitter TTHXXX $P_o = 38 \text{ mW}$, see also "Output power P_o for transmitters of ABB" on page 6.

$$\Delta t = 200 \text{ K/W} \times 0.038 \text{ W} = 7.6 \text{ K}$$

Therefore, at transmitter output power $P_o = 38 \text{ mW}$, the temperature rise in the event of a fault is approximately 8 K. This results in the following maximum possible process temperatures T_{medium} , as shown in the table "Maximum process temperature T_{medium} in Zone 0:" on page 7.

2.2.3 Intrinsic safety ATEX "Ex i"

Suitable thermowells in accordance with PTB 01 ATEX 2200 X are to be used.

In the area of the electrical connections, the permissible ambient temperature range is $-40 \dots 80^\circ \text{C}$ ($-40 \dots 176^\circ \text{F}$).

Electrical power limit Ex i

All of the values listed below are valid assuming that an additional transmitter has been connected. The following electrical values must not be exceeded:

U_i (input voltage)	I_i (input current)
30 V	101 mA
25 V	158 mA
20 V	309 mA

$$P_i \text{ (internal power)} = \max. 0.5 \text{ W}$$

Note: The internal power P_i corresponds to the output power P_o of the connected transmitter.

$$L_i \text{ (internal inductance)} = 15 \mu\text{H/m}$$

$$C_i \text{ (internal capacitance)} = 280 \text{ pF/m}$$

Output power P_o for transmitters of ABB

Transmitter type	P_o
TTH200 HART	$\leq 38 \text{ mW}$
TTH300 HART	$\leq 38 \text{ mW}$
TTH300 PA	$\leq 38 \text{ mW}$
TTH300 FF	$\leq 38 \text{ mW}$

All other information required to prove intrinsic safety (U_o , I_o , P_o , L_o , C_o etc.) can be taken from the type examination certificates for the relevant transmitter models.

Maximum process temperature T_{medium} in Zone 0:

The surface temperature of Category 1 devices must not exceed 80 % of the ignition temperature of a flammable gas or liquid. For the temperature T_{medium} , the temperature increase of 8 K in case of fault calculated as an example in chapter "Conditions for the use in potentially explosive areas" on page 6 is considered here.

Temperature class	80 % of the ignition temperature	T_{medium}
T1 (450 °C (842 °F))	360 °C (680 °F)	352 °C (665.5 °F)
T2 (300 °C (572 °F))	240 °C (464 °F)	232 °C (449.6 °F)
T3 (200 °C (392 °F))	160 °C (320 °F)	152 °C (305.6 °F)
T4 (135 °C (275 °F))	108 °C (226.4 °F)	100 °C (212 °F)
T5 (100 °C (212 °F))	80 °C (176 °F)	72 °C (161.6 °F)
T6 (85 °C (185 °F))	68 °C (154.4 °F)	60 °C (140 °F)

Maximum process temperature T_{medium} in Zone 1:

To calculate the temperature classes for T3, T4, T5 and T6, 5 K in each instance must be deducted; for T1 and T2, 10 K in each instance must be deducted.

Temperature class	-5 K	-10 K	T_{medium}
T1 (450 °C (842 °F))	–	440 °C (824 °F)	432 °C (809.6 °F)
T2 (300 °C (572 °F))	–	290 °C (554 °F)	282 °C (539.6 °F)
T3 (200 °C (392 °F))	195 °C (383 °F)	–	187 °C (368.6 °F)
T4 (135 °C (275 °F))	130 °C (266 °F)	–	122 °C (251.6 °F)
T5 (100 °C (212 °F))	95 °C (203 °F)	–	87 °C (188.6 °F)
T6 (85 °C (185 °F))	80 °C (176 °F)	–	72 °C (161.6 °F)

2.2.4 Flameproof enclosure "Ex d" (only TSP3X1)

The enclosures for thermometers of this design are flameproof. An explosion inside the thermometer will not ignite the explosive atmosphere in the area in which the device is located. Alongside the use of a flameproof enclosure, this is achieved by compliance with specified ignition gap lengths and widths (between enclosure and measuring inset) and "Ex d" certified cable entries.

SensyTemp TSP300 temperature sensors can be used as "Ex d" versions in the following zones provided that the corresponding requirements are met:

- With suitable thermowell and connection head in Zone 1 / 0 (zone separation, thus measuring inset in Zone 0).
- With connection head but without thermowell, in Zone 1

These thermometers hold type examination certificate PTB 99 ATEX 1144 with Ex marking II 1/2 G Ex d IIC T1-T6 Ga/Gb. The connection conditions listed there are to be complied with.

The self-heating of the sensor, in accordance with the chapter "Thermal resistance" on page 6 must be taken into consideration when connecting to transmitters and supply isolators that are not intrinsically safe.

The temperature class and the maximum permissible temperature of the measuring medium must be determined accordingly.

Temperature ranges:

Maximum permissible ambient temperature: -40 ... 60 °C (-40 ... 140 °F)

Maximum permissible temperature in connection head:

Temperature class	Without transmitter	With transmitter
T1 ... T4	125 °C (254 °F)	85 °C (185 °F)
T5	90 °C (194 °F)	82 °C (179.6 °F)
T6	75 °C (167 °F)	67 °C (152.6 °F)

Maximum process temperature T_{medium}

Temperature class	Use in Zone 0	Use in Zone 1
T1	358 °C (676.4 °F)	438 °C (820.4 °F)
T2	238 °C (460.4 °F)	288 °C (550.4 °F)
T3	158 °C (316.4 °F)	193 °C (379.4 °F)
T4	106 °C (222.8 °F)	128 °C (262.4 °F)
T5	78 °C (172.4 °F)	93 °C (199.4 °F)
T6	66 °C (150.8 °F)	78 °C (172.4 °F)

2.2.5 Dust explosion protection (enclosure) (only TSP3X1)

The power feed can come from a power supply unit with an intrinsically-safe output current circuit of type of protection "Ex ia IIB" or "Ex ia IIC", or can be non-intrinsically safe. In the case of a non-intrinsically-safe power feed, the current must be limited by an upstream fuse with a fuse nominal current of 32 mA. The output circuit current of the transmitter (sensor circuit current) is to be limited to a maximum power of 0.5 W. Highest value of thermal data for connection to an intrinsically-safe power supply unit of type of protection "Ex ia IIB / IIC"; refer to the "Thermal data" table.

NOTICE

When using two transmitters and/or measuring insets, the sum of the voltages, currents and outputs must not exceed the values specified in the type examination certificate.

Thermal data

	Approved ambient temperature at connection head	Approved process temperature at thermowell	Maximum temperature at the process connection on the connection head side	Maximum surface temperature at the connection head	Maximum surface temperature at the thermowell
Category 1D or Category 1/2 with intrinsically-safe transmitter installed	-40 ... 85 °C (-40 ... 185 °F)	-40 ... 85 °C (-40 ... 185 °F) -40 ... 200 °C (-40 ... 392 °F) ¹⁾ -40 ... 300 °C (-40 ... 572 °F) ¹⁾ -40 ... 400 °C (-40 ... 752 °F) ¹⁾	85 °C (185 °F) 164 °C (327.2 °F) 251 °C (483.8 °F) 346 °C (654.8 °F)	120 °C (248 °F)	133 °C (271.4 °F) 200 °C (392 °F) 300 °C (572 °F) 400 °C (752 °F)
Category 1D or Category 1/2 with fuse protection of installed transmitter by means of external IEC fuse	-40 ... 85 °C (-40 ... 185 °F)	-40 ... 85 °C (-40 ... 185 °F) -40 ... 200 °C (-40 ... 392 °F) ¹⁾ -40 ... 300 °C (-40 ... 572 °F) ¹⁾ -40 ... 400 °C (-40 ... 752 °F) ¹⁾	85 °C (185 °F) 164 °C (327.2 °F) 251 °C (483.8 °F) 346 °C (654.8 °F)	133 °C (271.4 °F) ²⁾ 150 °C (302 °F) ³⁾	133 °C (271.4 °F) 200 °C (392 °F) 300 °C (572 °F) 400 °C (752 °F)
Category 1D or category 1/2D measuring loop, intrinsically-safe transmitter, external or non-intrinsically-safe by means of external IEC fuse in the power feed circuit of the external transmitter	-40 ... 85 °C (-40 ... 185 °F) -40 ... 120 °C (-40 ... 248 °F) -40 ... 120 °C (-40 ... 248 °F) -40 ... 120 °C (-40 ... 248 °F)	-40 ... 85 °C (-40 ... 185 °F) -40 ... 200 °C (-40 ... 392 °F) -40 ... 300 °C (-40 ... 572 °F) -40 ... 400 °C (-40 ... 752 °F)	85 °C (185 °F) 200 °C (392 °F) 251 °C (483.8 °F) 346 °C (654.8 °F)	85 °C (185 °F) 200 °C (392 °F) 200 °C (392 °F) 200 °C (392 °F)	133 °C (271.4 °F) 200 °C (392 °F) 300 °C (572 °F) 400 °C (752 °F)

1) The user must take suitable measures to ensure that the maximum permissible ambient temperature of 85 °C (185 °F) at the connection head is not exceeded.

2) Fitted with a transmitter with and without display.

3) Fitted with two transmitters.

2.2.6 Non-sparking and dust explosion protection

External measures must be made for the power supply circuit in order to prevent the rated voltage from being exceeded by more than 40% in the event of transient disturbances.

The ambient temperature depends on the process temperature. The lower limit is -40 °C (-40 °F). The upper limit of the ambient temperature is presented in the following table:

Process temperature	Extension tube 150 mm	Extension tube 250 mm
100 °C (212 °F)	65 °C (149 °F)	70 °C (158 °F)
200 °C (392 °F)	60 °C (140 °F)	70 °C (158 °F)
300 °C (572 °F)	60 °C (140 °F)	70 °C (158 °F)
400 °C (752 °F)	55 °C (131 °F)	65 °C (149 °F)

For integrated TTH200 or TTH300 transmitters and the T6 temperature class, the maximum permissible ambient temperature is 56 °C (132.8 °F).

Process temperature: max. 400 °C (752 °F) for II 3G
max. 300 °C (572 °F) for II 3D

2.3 Installation instructions

Avoid increases in the ambient temperature by ensuring equipment is at a sufficient distance from system components with excessively high temperatures. It must be ensured that heat dissipation can take place by means of unrestricted air circulation. You must avoid exceeding the maximum permissible ambient temperature as per the approved temperature class.

The assembly and disassembly may only be performed by specialist personnel who have knowledge of the concept of the corresponding types of Ex protection. Compliance with the Ex temperature classes must be ensured through suitable measures.

It is essential to ensure compliance with the EC-type-examination certificates for the equipment, including the documents associated with these.

The temperature sensors must be integrated in the potential equalization of the installation location.

The installation, commissioning, maintenance and repair of devices in potentially explosive atmospheres must only be carried out by appropriately trained personnel. Works may be carried out only by persons, whose training has included instructions on different types of protection and installation techniques, concerned rules and regulations as well as general principles of zoning. The person must possess the relevant expertise for the type of works to be executed.

When operating with combustible dusts, EN 60079-31 must be complied with.

The safety instructions for electrical apparatus in potentially explosive areas must be complied with, in accordance with the directive 2014/34/EU (ATEX) and e.g. IEC 60079-14 (Installation of equipment in potentially explosive atmospheres).

To ensure safe operation, the respectively applicable requirements must be met for the protection of workers.

2.3.1 Cable entries

Devices with type of protection Ex d supplied without cable glands

For devices with type of protection Ex d "flameproof enclosure" supplied without cable glands, refer to the information in Chapter "Flameproof enclosure (model TSA101-A5, TSP3X1-A5)" on page 11.

For information on the cable gland used, refer to the relevant data sheet and operating instructions.

Devices with the type of protection "Ex d" with cable glands

For devices with the type of protection Ex d "flameproof enclosure", a correspondingly certified cable entry is installed if the relevant selection is made for cable entry into the TSP300 temperature sensor. This meets the basic requirements of the directive 2014/34/EU.

Data of the standard cable gland

- M20 x 1.5 or 1/2 in. NPT
- Temperature range: -40 ... 120 °C (-40 ... 248 °F)
- Cable outer diameter: 3.2 ... 8.7 mm (0.13 ... 0.34 inch)
- Brass, nickel-plated

The cable entry is only suitable for fixed installations and non-reinforced cables with round and smooth plastic sleeves and suitable outer diameters. The cables must be attached appropriately in order to prevent them being pulled out or twisted.

The operating instructions supplied with the cable glands, any approvals and all applicable requirements in accordance with EN 60079-14 must be taken into account accordingly.

Assembly instructions

The sealing rings of the cable glands harden at low temperatures.

Before installation, bring the sealing rings to a temperature of at least 20 °C (68 °F) for 24 hours.

Before inserting the sealing rings and fixing them onto the cable gland, knead the rings to ensure they are soft and flexible.

IP rating IP66 / 67 is only achieved by installing the black neoprene sealing ring between the cable gland and the housing and by observing the tightening torque of 3.6 Nm (Fig. 2, item ②).

Cables must be protected against extreme mechanical loads (caused by tension, torsion, crushing, etc.). Even under operating conditions, it must be ensured that the cable entry remains hermetically sealed. The customer must provide a strain relief device for the cable.

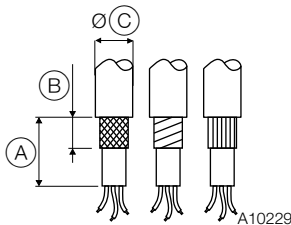

Fig. 1: Stripping of connection cable

Ⓐ 40 mm (1.57 inch) Ⓑ 12 mm (0.47 inch) Ⓒ \varnothing 8.5 / 12 mm (0.33 / 0.47 inch)

1. Check that cable used is suitable (i.e., check the mechanical resilience, temperature range, creep resistance, resistance to chemicals, outer diameter, etc.).
2. Strip the cable in accordance with Fig. 1.
3. Check the outer sleeve for damage and soiling.
4. Insert the cable in the cable gland.

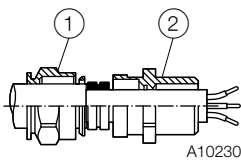

Fig. 2: Tighten cable gland

5. Tighten the cable gland until the cable is firmly enclosed by the sealing ring (Fig. 2, item ①). Do not tighten by more than 1.5-times the specified torque on the housing (see assembly instructions).

Maintenance

Check the cable glands during each maintenance session. If the cable is slack, retighten the cap(s) of the cable glands. If it is not possible to retighten them, the cable gland will need to be replaced.

M20 x 1.5 plastic cable gland for various types of protection

The default M20 x 1.5 plastic cable gland has a limited temperature range. The permissible ambient temperature range of the cable gland is -40 ... 70 °C (-40 ... 158 °F). When using the cable gland, make sure that the ambient temperature is within this range.

The cable gland must be installed in the housing with a tightening torque of 3.75 Nm. On the cable side, when installing the connection of the cable gland and cable, check for integrity to ensure that the required IP rating is met.

Intrinsic safety up to Zone 0 (model TSA101-A1, TSPXX1-A1)

**ATEX II 1 G Ex ia IIC T6 Ga (Zone 0, 1, 2) or
ATEX II 2 G Ex ib IIC T6 Gb (Zone 1, 2) or
ATEX II 1/2 G Ex ib IIC T6 Ga/Gb Zone 0 by zone
separation with thermowell, Zone 1, 2)**

ATEX II 1 G Ex ia IIC T6 Ga, Zone 0, 1, 2:

When used in Zone 0, the use of connection heads made of aluminum is not permitted. Moreover, no additional specific information needs to be observed for mechanical installation.

ATEX II 2 G Ex ib IIC T6 Gb, Zone 1, 2:

No additional specific information needs to be observed for mechanical installation.

ATEX II 1/2 G Ex ib IIC T6 Ga/Gb, Zone 0 by zone separation with thermowell, Zone 1, 2:

If the assembly of temperature sensors is carried in thermowells or isolating elements are used, temperature sensors in the certified intrinsically safe "ib" circuits may also be assigned to the category 1. The minimum wall thickness is ≥ 1 mm for rust-free steels or ≥ 3 mm for other steels. This applies to all temperature sensors of SensyTemp TSP1X1 and TSP3X1 and is to be observed especially when installing the SensyTemp TSP111 and TSP311 temperature sensors in existing thermowells. Moreover, no additional specific information needs to be observed for mechanical installation.

Intrinsic safety up to Zone 0 according to NAMUR recommendation (model TSA101-N1, TSPXX1-N1)

NE 24 and ATEX II 1 G Ex ia IIC T6 Ga, Zone 0, 1, 2

No additional specific information needs to be observed for mechanical installation.

**Dust explosion protection (model TSA101-A3, TSP3X1-A3)
ATEX II 1 D Ex tD A20 IP66 T133°C ... T400°C, Zone 20, 21, 22**

The assembly and disassembly may only be carried out by specialist personnel that have knowledge of the concept of the corresponding type of protection "Electrical apparatuses with protection through housing with isolation of the surface temperature for use in areas in which combustible dust is present in sufficient quantities that it could lead to fire or explosion (dust explosion protection)".

The temperature sensors are to be attached, according to their mounting type (thermowell with flange, with threaded connector, with sliding connector or as welded thermowell), securely, sealed and firmly with the respective container.

Choose connection elements that are suitable for the application in question. (Screws, seals etc.)

Only use connection cables that satisfy the requirements of the standard series DIN EN 60079.

SensyTemp TSP3X1 temperature sensors must be installed in an existing thermowell.

Dust explosion protection and intrinsic safety (model TSA101-A4, TSP3X1-A4)

**ATEX II 1 D Ex tD A20 IP66 T133°C ... T400°C and
ATEX II 1 G Ex ia IIC T6 Ga or II 2 G Ex ib IIC T6 Gb or II
1/2 G Ex ib IIC T6 Ga/Gb, Zone 0, 1, 2, 20, 21, 22**

The chapter "Intrinsic safety up to Zone 0 (model TSA101-A1, TSPXX1-A1)" on page 10 and "Dust explosion protection (model TSA101-A3, TSP3X1-A3)" on page 11 are to be applied for this.

i NOTICE

Use in explosive hybrid mixtures (where explosive dusts and gases are present simultaneously) is not currently permitted in accordance with EN 60079-0 and EN 61241-0.

Flameproof enclosure (model TSA101-A5, TSP3X1-A5)

ATEX II 1/2 G Ex d IIC T1-T6 Ga/Gb, Zone 1 and 2

For Zone 0, thermowells which satisfy the following requirements must be used:

- Install suitable thermowells for zone separation.
SensyTemp TSP321 and TSP331 temperature sensors are supplied with an appropriate thermowell. SensyTemp TSP311 temperature sensors must be installed in an existing thermowell.
- Suitable temperature-, pressure- and corrosion-resistant sealing elements must be used.

Use only prototype-certified ABB measuring insets whose diameter matches the corresponding hole of the connection head (ignition penetration-proof seam).

If there is surface damage in the area of the ignition penetration-proof seam of the measuring inset or the connection head base, the defective components may no longer be used.

- Observe the approval and assembly instructions for the cable gland. For information on the cable gland used, refer to the relevant data sheet and operating instructions. When using as a surface sensor with exposed mineral insulated cable (custom-made), this cable must be permanently installed and mechanically protected.

Dust explosion protection and flameproof enclosure (model TSA101-B5, TSP3X1-B5)

ATEX II 1 D Ex tD A20 IP66 T133°C or T200°C or T300°C or T400°C and

ATEX II 1/2 G Ex d IIC T1-T6 Ga/Gb, Zone 1, 2, 20, 21, 22

Chapters "Dust explosion protection (model TSA101-A3, TSP3X1-A3)" on page 11 and "Flameproof enclosure (model TSA101-A5, TSP3X1-A5)" on page 11 must be applied in respect of this.

i NOTICE

Use in explosive hybrid mixtures (where explosive dusts and gases are present simultaneously) is not permitted in accordance with EN 60079-0 and EN 61241-0.

Non-sparking and dust explosion protection (model TSA101-B1, TSPXX1-B1)

ATEX II 3 G Ex nA IIC T1-T6 Gc

ATEX II 3 D Ex tc IIIB T133°C Dc, Zone 2 and 22

No additional specific information needs to be observed for mechanical installation.

i NOTICE

Use in explosive hybrid mixtures (where explosive dusts and gases are present simultaneously) is not permitted in accordance with EN 60079-0 and EN 61241-0.

2.4 Electrical connections

Grounding

If, for functional reasons, the intrinsically safe circuit needs to be grounded by means of a connection to the potential equalization, it may only be grounded at one point.

Intrinsic safety proof

If the temperature sensors are operated in an intrinsically safe circuit, proof that the interconnection is intrinsically safe must be provided in accordance with DIN VDE 0165/Part 1 (EN 60079-25/ and IEC 60079-25).

The supply isolators / DCS inputs must feature intrinsically safe input protection circuits in order to eliminate hazards (spark formation).

In order to provide proof of intrinsic safety, the electrical limit values must be used as the basis for the EC type examination certificates for the equipment (devices); this includes the capacitance and inductance values of the cables.

Proof of intrinsic safety is said to have been provided if the following conditions are fulfilled when a comparison is carried out in relation to the limit values of the equipment:

Transmitters (intrinsically safe equipment)		Supply isolator / DCS input (related equipment)
U_i	\geq	U_o
I_i	\geq	I_o
P_i	\geq	P_o
$L_i + L_c$ (cable)	\leq	L_o
$C_i + C_c$ (cable)	\leq	C_o

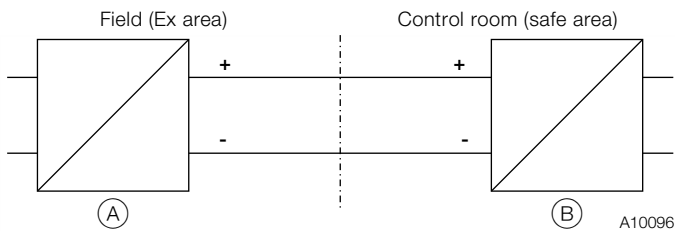

Fig. 3
 (A) Transmitter (B) Supply isolator / DCS input with supply / segment coupler

2.4.1 Installation in potentially explosive areas without integrated transmitter

The temperature sensor can be installed in a huge variety of industrial locations. Plants with explosion protection (Ex plants) are divided into zones, meaning that they also require a wide range of instruments. Different certificates are required for these depending on region. The temperature sensor must be instrumented by the user in accordance with the valid Ex standards.

i NOTICE

Ex relevant specifications must be taken from the EC-type-examination certificates and other relevant certificates that apply respectively.

Intrinsic safety up to Zone 0 (model TSA101-A1, TSPXX1-A1)

ATEX II 1 G Ex ia IIC T6 Ga Zone 0, 1, 2 or

ATEX II 2 G Ex ib IIC T6 Gb Zone 1, 2 or

ATEX II 1/2 G Ex ib IIC T6 Ga/Gb Zone 0 by zone separation with thermowell, Zone 1, 2

Only certified transmitters with the maximum values specified in the operating instructions may be connected to the temperature sensors. If two transmitters are used for two intrinsically safe circuits, the sum of the values may not exceed the maximum values specified in the operating instructions.

The temperature sensor must feature appropriate input protection circuits in order to eliminate hazards (spark formation). The intrinsic safety installation must be checked. For this, the electrical limit values must be used as the basis for the type examination certificates for the equipments (devices); this includes the capacitance and inductance values of the connection leads.

ATEX II 1 G Ex ia IIC T6 Ga, Zone 0, 1, 2:

In the case of the intrinsic safety type of protection, only one measuring element may be connected in Zone 0 if two measuring elements are being used (e.g. 2 x Pt100).

The internal wiring in TTF300 transmitters enables 2 measuring elements to be connected, as both elements are integrated into the same intrinsically safe sensor circuit.

For the Zone 0 design, only one intrinsically safe sensor measurement circuit may be used.

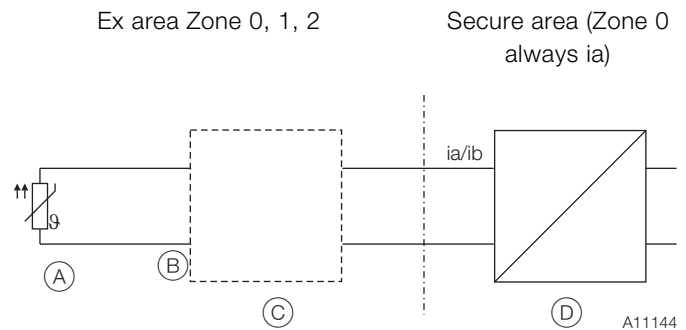

Fig. 4: Interconnection
 (A) Sensor (B) Sensor connection leads (C) Housing
 (D) Transmitter Ex ia/ib (Zone 0 always ia)

The transmitter must have an Ex ia (Category 1G) design to enable it to be used in Zone 0.

ATEX II 2 G Ex ib IIC T6 Gb Zone 1, 2:

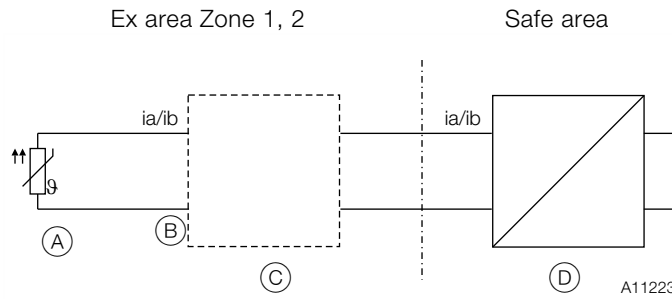

Fig. 5: Interconnection
 (A) Sensor (B) Sensor connection leads (C) Housing
 (D) Transmitter Ex ia/ib

ATEX II 1/2 G Ex ib IIC T6 Ga/Gb, Zone 0 by zone separation with thermowell, Zone 1, 2:

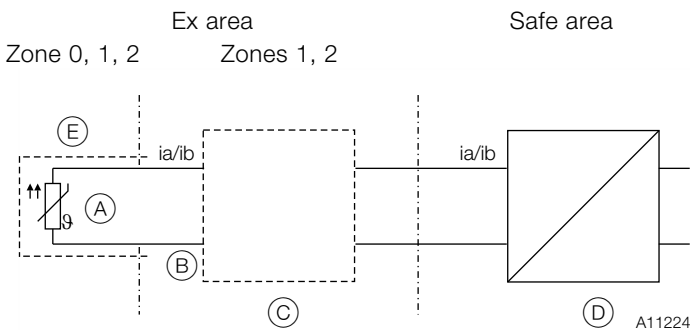

Fig. 6: Interconnection
 (A) Sensor (B) Sensor connection leads (C) Housing
 (D) Transmitter Ex ia/ib (E) Thermowell, suitable for zone separation

Intrinsic safety up to Zone 0 according to NAMUR recommendation (model TSA101-N1, TSPXX1-N1)

NE 24 and ATEX II 1 G Ex ia IIC T6 Ga, Zone 0, 1, 2
 See the chapter titled "Intrinsic safety up to Zone 0 (model TSA101-A1, TSPXX1-A1)" on page 12.

NOTICE

Due to the geometric dimensions within the mineral insulated cable, double sensors may not satisfy the requirements of Point 2 of NAMUR recommendation NE 24.

**Dust explosion protection (model TSA101-A3, TSP3X1-A3)
 ATEX II 1 D Ex tD A20 IP66 T133°C ... T400°C, Zone 20, 21, 22**

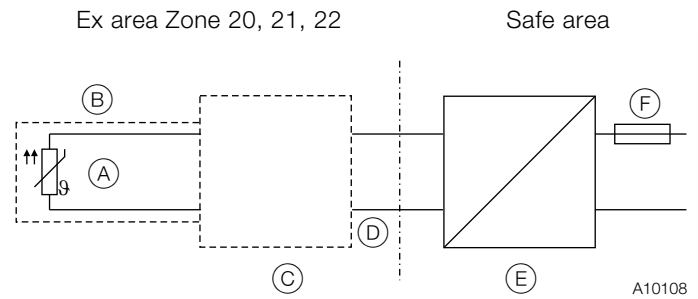

Fig. 7: Interconnection
 (A) Sensor (B) Thermowell (C) Ex d approved housing with Ex d cable gland
 (D) Sensor connection leads (E) Transmitter
 (F) Fuse 32 mA

The transmitter supply current must be limited by an upstream fuse with a fuse nominal current of 32 mA. This is not required if the transmitter has an intrinsically safe design according to Chapter "Intrinsic safety up to Zone 0 (model TSA101-A1, TSPXX1-A1)" on page 12.

Dust explosion protection and intrinsic safety (model TSA101-A4, TSP3X1-A4)

**ATEX II 1 D Ex tD A20 IP66 T133°C ... T400°C and
 ATEX II 1 G Ex ia IIC T6 Ga or II 2 G Ex ib IIC T6 Gb or II
 1/2 G Ex ib IIC T6 Ga/Gb, Zone 0, 1, 2, 20, 21, 22**
 See Chapters "Intrinsic safety up to Zone 0 (model TSA101-A1, TSPXX1-A1)" on page 12 and "Dust explosion protection (model TSA101-A3, TSP3X1-A3)" on page 13.

**Flameproof enclosure (model TSA101-A5, TSP3X1-A5)
 ATEX II 1/2 G Ex d IIC T1-T6 Ga/Gb, Zone 1 and 2**

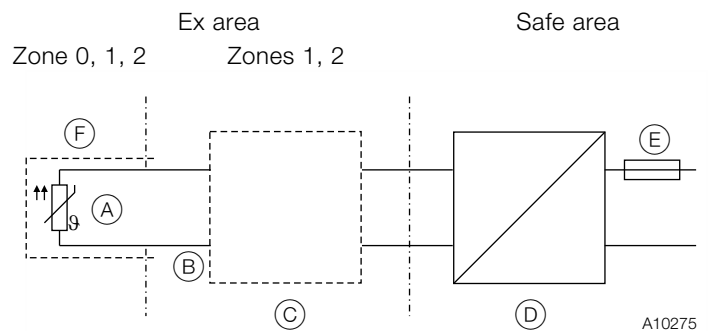

Fig. 8: Interconnection
 (A) Sensor (B) Sensor connection leads (C) Ex d housing (IP 6X) with Ex d cable gland
 (D) Transmitter Ex ia/ib (E) Fuse 32 mA
 (F) Thermowell, suitable for zone separation

The transmitter supply current must be limited by an upstream fuse with a fuse nominal current of 32 mA.

The voltage in the measuring loop (sensor connection lead) must be limited to 30 V.

No current or voltage limitation is required if the transmitters and supply are designed and operated in an intrinsically safe manner in accordance with chapter "Intrinsic safety up to Zone 0 (model TSA101-A1, TSPXX1-A1)" on page 12 .

I NOTICE

When used without a thermowell, particularly surface sensors with exposed mineral insulated cable, operation in Zone 0 is not permitted.

To account for self-heating, the power limitation (current, voltage) must be adapted in accordance with chapter "Temperature rise in the event of a fault" on page 6 when using non-intrinsically safe transmitters and supply isolators.

Dust explosion protection and flameproof enclosure (model TSA101-B5, TSP3X1-B5)

ATEX II 1 D Ex tD A20 IP66 T133°C or T200°C or T300°C or T400°C and

ATEX II 1/2 G Ex d IIC T1-T6 Ga/Gb, Zone 1, 2, 20, 21, 22

See Chapters "Dust explosion protection (model TSA101-A3, TSP3X1-A3)" on page 13 and "Flameproof enclosure (model TSA101-A5, TSP3X1-A5)" on page 13.

Non-sparking and dust explosion protection (model TSA101-B1, TSPXX1-B1)

ATEX II 3 G Ex nA IIC T1-T6 Gc

ATEX II 3 D Ex tc IIIB T133°C Dc, Zone 2 and 22

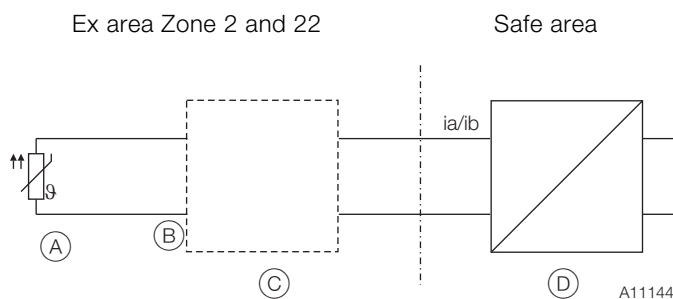

Fig. 9: Interconnection

- (A) Sensor (B) Sensor connection leads (C) Housing with IP 6X
- (D) Transmitter

External measures must be made for the power supply circuit in order to prevent the rated voltage from being exceeded by more than 40% in the event of transient disturbances.

2.4.2 Installation in potentially explosive areas with integrated transmitter

Intrinsic safety up to Zone 0 (model TSA101-A1, TSPXX1-A1)

ATEX II 1 G Ex ia IIC T6 Ga Zone 0, 1, 2 or

ATEX II 2 G Ex ib IIC T6 Gb Zone 1, 2 or

ATEX II 1/2 G Ex ib IIC T6 Ga/Gb Zone 0 by zone separation with thermowell, Zone 1, 2

With this instrumentation, it must be ensured that the power feed only comes from an approved intrinsically safe electrical circuit of the appropriate category.

The electrical and thermal parameters may not be exceeded, see chapter "Thermal data" on page 8.

ATEX II 1 G Ex ia IIC T6 Ga Zone 0, 1, 2:

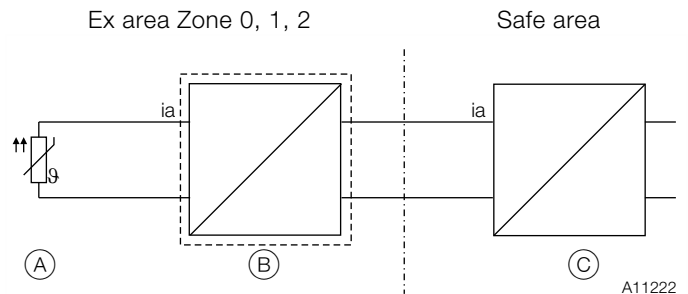

Fig. 10: Interconnection

- (A) Measuring inset (B) Head-mount transmitter Ex nA, e.g. TTH200 or TTH300 (C) Supply isolator [Ex ia]

ATEX II 2 G Ex ib IIC T6 Gb Zone 1, 2:

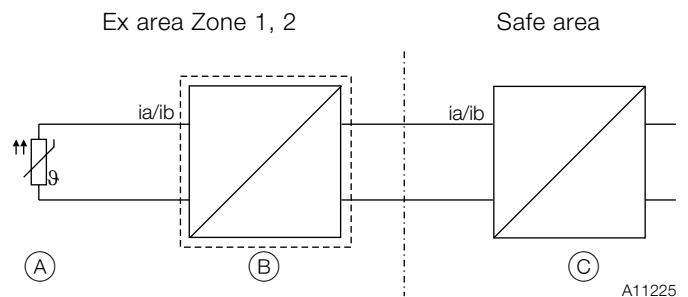

Fig. 11: Interconnection

- (A) Sensor (B) Head-mount transmitter Ex ia/ib (C) Supply isolator [Ex ib]

ATEX II 1/2 G Ex ib IIC T6 Ga/Gb Zone 0 by zone separation with thermowell, Zone 1, 2:

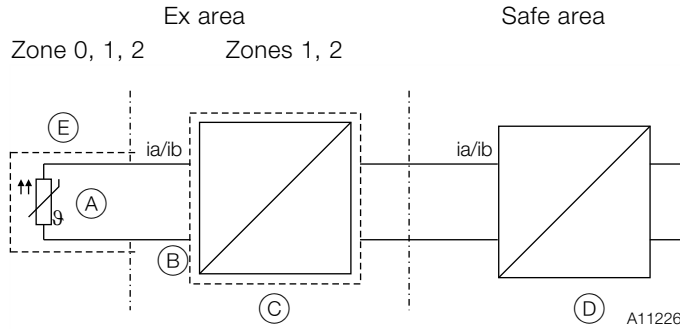

Fig. 12: Interconnection
 (A) Sensor (B) Sensor connection lead (C) Housing (D) Head-mount transmitter Ex ia/ib, e.g. TTH200 or TTH300 (E) Thermowell, suitable for zone separation

Intrinsic safety up to Zone 0 according to NAMUR recommendation (model TSA101-N1, TSPXX1-N1) NE 24 and ATEX II 1 G Ex ia IIC T6 Ga, Zone 0, 1, 2

See chapter "Intrinsic safety up to Zone 0 (model TSA101-A1, TSPXX1-A1)" on page 14.

NOTICE

Due to the geometric dimensions within the mineral insulated cable, double sensors may not satisfy the requirements of Point 2 of NAMUR recommendation NE 24.

Dust explosion protection (model TSA101-A3, TSP3X1-A3) ATEX II 1D Ex tD A20 IP66 T133°C ... T400°C, Zone 20, 21, 22

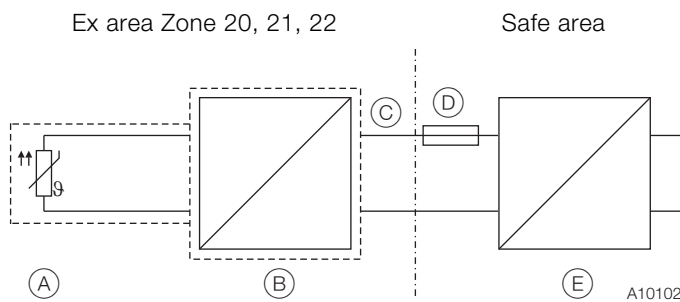

Fig. 13: Interconnection
 (A) Measuring inset with thermowell (B) Transmitter (C) Ex d approved housing with Ex d cable gland (D) Fuse (E) Supply isolator
 The transmitter supply current must be limited by an upstream fuse with a fuse nominal current of 32 mA. This is not required if the transmitter has an intrinsically safe design according to Chapter "Intrinsic safety up to Zone 0 (model TSA101-A1, TSPXX1-A1)" on page 14.

Dust explosion protection and intrinsic safety (model TSA101-A4, TSP3X1-A4)

ATEX II 1D Ex tD A20 IP66 T133°C ... T400°C and ATEX II 1 G Ex ia IIC T6 Ga or II 2 G Ex ib IIC T6 Gb or ATEX II 1/2 G Ex ib IIC T6 Ga/Gb, Zone 0, 1, 2, 20, 21, 22
 See Chapters "Intrinsic safety up to Zone 0 (model TSA101-A1, TSPXX1-A1)" on page 14 and "Dust explosion protection (model TSA101-A3, TSP3X1-A3)" on page 15.

Flameproof enclosure (model TSA101-A5, TSP3X1-A5) ATEX II 1/2 G Ex d IIC T1-T6 Ga/Gb, Zone 1 and 2

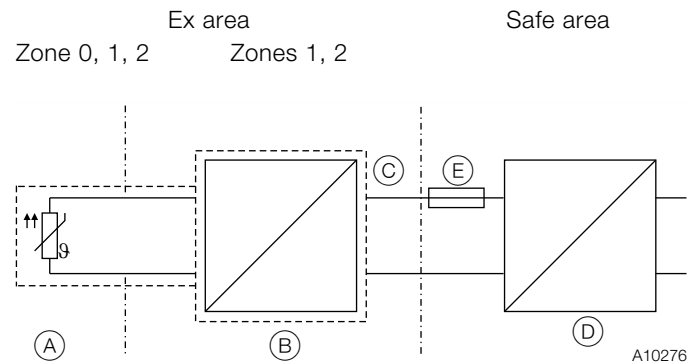

Fig. 14: Interconnection
 (A) Measuring inset with thermowell suitable for zone isolation (B) Head-mount transmitter (C) Ex d housing (IP 6X) with Ex d cable gland (D) Supply isolator with current- and voltage limitation (32 mA, 30 V) (E) Fuse 32 mA

The transmitter supply current must be limited by an upstream fuse with a fuse nominal current of 32 mA.

The voltage in the measuring loop (sensor connection lead) must be limited to 30 V.

No current or voltage limitation is required if the transmitters and supply are designed and operated in an intrinsically safe manner in accordance with chapter "Intrinsic safety up to Zone 0 (model TSA101-A1, TSPXX1-A1)" on page 14.

NOTICE

When used without a thermowell, particularly surface sensors with exposed mineral insulated cable, operation in Zone 0 is not permitted.

To account for self-heating, the power limitation (current, voltage) must be adapted in accordance with chapter "Temperature rise in the event of a fault" on page 6 when using non-intrinsically safe transmitters and supply isolators.

**Dust explosion protection and flameproof enclosure
(model TSA101-B5, TSP3X1-B5)**

ATEX II 1D Ex tD A20 IP66 T133°C or T200°C or T300°C or T400°C and

ATEX II 1/2 G Ex d IIC T1-T6 Ga/Gb, Zone 1, 2, 20, 21, 22

See Chapters "Dust explosion protection (model TSA101-A3, TSP3X1-A3)" on page 15 and "Flameproof enclosure (model TSA101-A5, TSP3X1-A5)" on page 15.

**Non-sparking and dust explosion protection (model
TSA101-B1, TSPXX1-B1)**

ATEX II 3 G Ex nA IIC T1-T6 Gc

ATEX II 3 D Ex tc IIIB T133°C Dc, Zone 2 and 22

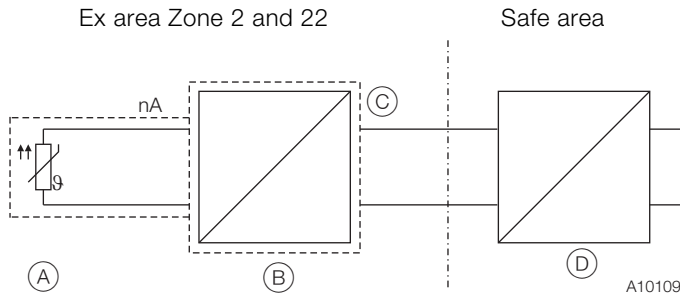

Fig. 15: Interconnection

(A) Measuring inset (B) Head-mount transmitter Ex nA in the connection head (C) Housing with IP 6X (D) Supply isolator

External measures must be made for the power supply circuit in order to prevent the rated voltage from being exceeded by more than 40% in the event of transient disturbances.

2.5 Commissioning

The commissioning and parameterization of the device may also be carried out in potentially explosive atmospheres using a handheld terminal that has been approved accordingly under consideration of an intrinsic safety installation check.

Alternatively, an Ex modem can be connected to the circuit outside the potentially explosive atmosphere.

2.6 Operating instructions

2.6.1 Protection against electrostatic discharges

The painted surface of the housing and the plastic parts inside the device can store electrostatic charges.

⚠ WARNING

Risk of explosion!

The device must not be used in areas in which process-related electrostatic charging of the housing may occur. The device must be maintained so that any dangerous electrostatic charge is avoided.

3 Function and system design

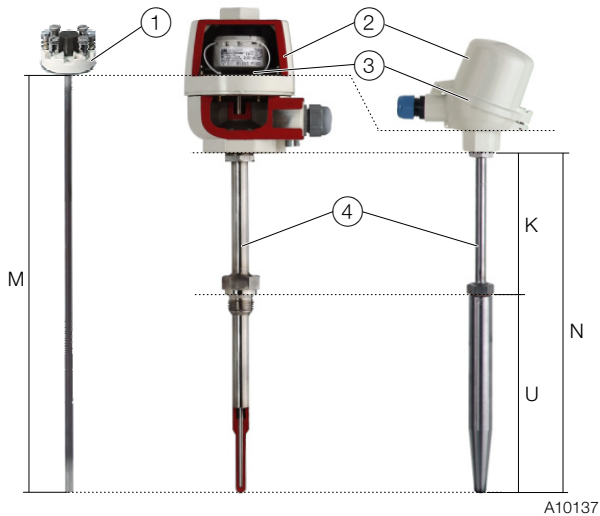

Fig. 16

① Measuring inset ② Connection head ③ Head-mount transmitter, optionally with LCD display ④ Extension tube

M Measuring inset length
K Extension tube length
N Nominal length
U Installation length

Process temperatures are measured using temperature sensors from the SensyTemp TSP1X1 and TSP3X1 series. These temperature sensors are suitable for measuring temperatures in the majority of processes.

The structure of the SensyTemp TSA101 measuring insets installed in the temperature sensors conforms to DIN 43735. Depending on the sensor, a resistance value (in the case of resistance temperature sensors) or a millivolt signal (in the case of thermocouple sensors) is output for the process temperature in question.

In the case of measuring insets with exposed wire ends or a ceramic connector base, this signal is transmitted without being converted. If a transmitter is mounted on the measuring inset, the temperature signal is converted into a scaled current or bus signal. Additional information is available for using the communication standard HART, PROFIBUS or FOUNDATION Fieldbus. The transmission of scaled signals for process evaluation does not depend on the distance and ambient conditions.

For the purpose of installing up to two transmitters or a combination of a transmitter and LCD indicator, covers of varying heights are available for the connection heads in accordance with DIN 43729. LCD-indicators are electrically connected to the transmitter and installed in connection heads with "D" at the end of their names (e.g., BUZHD). This ensures information can be displayed directly.

Current standards allow measuring insets to be replaced without the need for interruptions in operation. This involves simply opening the cover of the connection head. The measuring inset can be removed after unscrewing two mounting screws. Any non-standard explosion protection regulations must be observed.

The replacement of the measuring inset or the separating and closing of electrical connections may only be carried out if no explosive atmosphere is present.

The SensyTemp TSA101 measuring insets have been optimized for use with SensyTemp TSP1X1 and TSP3X1 temperature sensors. It is recommended that you use them in this combination only.

More detailed functional descriptions and information concerning the required transmitters can be found in the relevant data sheets and operating instructions.

4 Product identification

4.1 Name plate

i NOTICE

The name plates displayed are examples. The device identification plates affixed to the device can differ from this representation.

i NOTICE

The values specified on the name plate are maximum values and do not take process-related stress into consideration. This should be taken into consideration when working with the instruments.

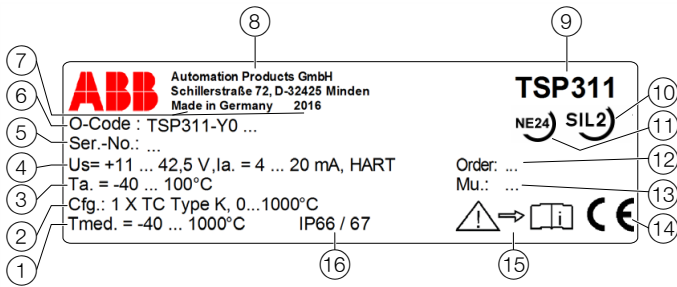

A10218

Fig. 17: Name plate TSP1x1, TSP3x1 (example)

- ① Medium temperature range (process temperature)
- ② Sensor configuration
- ③ Ambient temperature range (temperature at the connection head)
- ④ Specifications of the transmitter
- ⑤ Serial number
- ⑥ Order code
- ⑦ Country of manufacture / year of manufacture
- ⑧ Manufacturer
- ⑨ Type designation
- ⑩ SIL 2, logo only in combination with an integrated transmitter TTHx00
- ⑪ NE 24 conformity
- ⑫ Order number and position, e. g. 2400362 and 0010
- ⑬ Serial number of the transmitter (only for integrated transmitter TTHx00)
- ⑭ CE-marking (EU-conformity), if not on the additional plate
- ⑮ Note: follow product documentation
- ⑯ IP rating

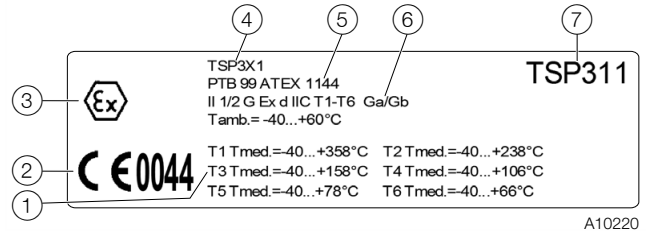

A10220

Fig. 18: Additional plate TSP1x1, TSP3x1 (example)

- ① Temperature range
- ② CE-marking (EU-conformity) and mentioned body for quality assurance
- ③ Ex-marking
- ④ Type designation in accordance with approval
- ⑤ Number of the approval
- ⑥ Protection class of explosion-proof design
- ⑦ Type designation

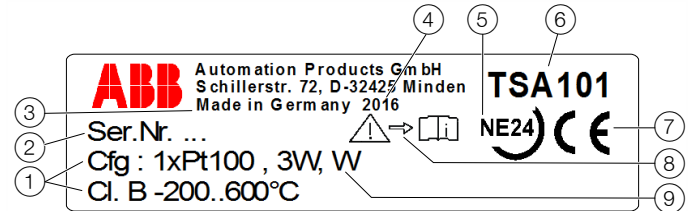

A10219

Fig. 19: Name plate TSA101 (example)

- ① Sensor configuration
- ② Serial number
- ③ Country of manufacture
- ④ Year of manufacture
- ⑤ NE 24 conformity
- ⑥ Type designation
- ⑦ CE-marking (EU-conformity)
- ⑧ Note: follow product documentation
- ⑨ Type of the measurement resistor: F = TF, W = WW

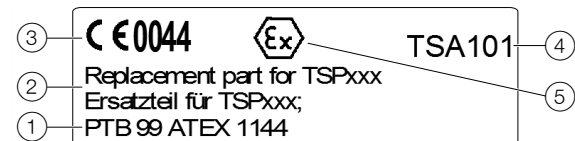

A10221

Fig. 20: Additional plate TSA101 (example)

- ① Number of the approval
- ② Note: Measuring inset only for installation in temperature sensor SensyTemp TSP1x1, TSP3x1
- ③ CE-marking (EU-conformity) and mentioned body of quality assurance
- ④ Type designation
- ⑤ Ex-marking

5 Functional safety (SIL)

SensyTemp TSP temperature sensors with SIL certified transmitters fitted ex works are available with conformity in accordance with IEC 61508 for use in safety-related applications up to SIL 3 (redundant). When using a transmitter, the device fulfills the requirements in accordance with SIL 2. When using two redundant transmitters, the device fulfills the requirements in accordance with SIL 3.

For the calculation of the safety integrity level (SIL) of a combination of SensyTemp TSP temperature sensors with a SIL certified transmitter that is not fitted from the factory – e.g. the temperature transmitter for field mounting TTF300 of ABB – the following instructions are to be followed:

Failure rates of temperature sensors

In the calculation of the safety integrity level (SIL) of a thermometer with temperature transmitter and -sensor in a safety-related application according to IEC 61508, the failure rates of the temperature sensor are incorporated.

The typical failure rates of the temperature sensors listed below are taken from the literature.

They are to be distinguished by the type of error (break, shorted, drift), by the vibration requirements at the place of application (low stress / high stress) as well as the type of the connection between the measuring point and temperature transmitter (close-coupled / extension wire).

Typical failure rates

Temperature sensor	Fault type	Low stress Close coupled	High stress Close coupled	Low stress Extension wire	High stress Extension wire
Thermocouple	Wire break	95 FIT	1900 FIT	900 FIT	18000 FIT
	Short circuit	4 FIT	80 FIT	50 FIT	1000 FIT
	Drift	1 FIT	20 FIT	50 FIT	1000 FIT
Four-wire resistance thermometer	Wire break	41.5 FIT	830 FIT	410 FIT	8200 FIT
	Short circuit	2.5 FIT	50 FIT	20 FIT	400 FIT
	Drift	6 FIT	120 FIT	70 FIT	1400 FIT
Two-/three-wire resistance thermometer	Wire break	37.92 FIT	758.5 FIT	370.5 FIT	7410 FIT
	Short circuit	1.44 FIT	28.8 FIT	9.5 FIT	190 FIT
	Drift	8.64 FIT	172.8 FIT	95 FIT	1900 FIT

Source: Exida: Safety Equipment Reliability Handbook - 3rd Edition, 2012, exida.com L.L.C.
Note: 1 FIT is 1 failure per 10⁹ hours.

Information regarding functional safety for TTx300 and TTx200 TSP temperature transmitter can be found in the SIL safety instructions.

6 Transport and storage

6.1 Inspection

Check the devices immediately after unpacking for possible damage that may have occurred from improper transport. Details of any damage that has occurred in transit must be recorded on the transport documents. All claims for damages must be submitted to the shipper without delay and before installation.

6.2 Transporting the device

Observe the following instructions:

- Do not expose the device to humidity during transport. Pack the device accordingly.
- Pack the device so that it is protected against vibrations during transport, e.g., by using air-cushioned packaging.

7 Installation

7.1 General information

- The temperature sensors (thermocouple, resistance thermometer) must be brought into maximum contact with the medium to be measured.
- The IP protection class will no longer apply in the event of damage to the connection head or the threads, seals, or cable glands on the connection head.
- The connection leads must be firmly connected to the connection terminals.
- The correct polarity must be ensured in the case of thermocouples.
- In the case of resistance thermometers, take note of whether a two-, three-, or four-wire circuit is being used.
- When installing temperature sensors in existing thermowells, make sure that the measuring inset can be inserted easily. If this is not the case, the inside of the thermowell will need to be cleaned.
- The temperature sensor must be firmly and securely installed in a way that conforms to the requirements of the application process.
- Please take note of the sensor and circuit type specified.
- After clamping the connection lines using a suitable tool (screwdriver, wrench), you must ensure that the connection heads are securely closed and sealed again. When doing this, make sure that the sealing rings of the connection heads are clean and undamaged.

7.2 Cable glands

SensyTemp TSP1X1 and TSP3X1 temperature sensors are supplied with a M20 x 1.5 cable gland.

The cable gland made of plastic supplied by default for cable outer diameter of 5.5 ... 13 mm (0.22 ... 0.51 inch) is suitable for a temperature range of -40 ... 70 °C (-40 ... 158 °F). For temperatures outside this range, an appropriate cable gland must be installed.

The metal cable gland used for Ex d (flameproof enclosure, only for TSP3X1) by default for cable outer diameter of 3.2 ... 8.7 mm (0.13 ... 0.34 inch) covers a temperature range of -40 ... 120 °C (-40 ... 248 °F).

Approved cable glands are used as appropriate for temperature sensors with Ex certification. If used correctly, these cable glands can help achieve an IP protection class of at least IP 66 (in the case of TSP1X1) or IP 66 / 67 (in the case of SensyTemp TSP3X1).

Alternatively, the temperature sensor can be supplied without cable glands but with an M20 x 1.5 or 1/2" NPT thread. In this case, the user must take appropriate measures to ensure that the necessary IP protection class is achieved, the temperature range is complied with and that the cable gland used is approved in accordance with the standard on which the certificate is based.

To achieve the IP protection class, the used cable gland must be approved for the cable diameter. The IP protection class IP 66 / IP 67 or NEMA 4X of the used cable gland is to be examined. The operating temperature range of the cable gland used must not be exceeded.

The Ex relevant specifications of the cable gland used are to be verified based on the manufacturer's data sheet or Ex certificate. Likewise, the tightening torque in accordance with specification in data sheet / operating instruction for the cable gland used is to be followed.

With this option it is also necessary to ensure that the measures taken satisfy the relevant requirements and standards concerning explosion protection as well as the approvals for the relevant temperature sensors (e.g. PTB 99 ATEX 1144 for Ex d).

In practice, you may find the specified IP protection class can no longer be achieved if certain cables and lines are used in conjunction with the cable gland. Deviations from the test conditions as set out in the IEC 60529 standard must be checked. Check the cables' concentricity, transposition, external hardness, sheath, and surface roughness.

7.2.1 Prerequisites for achieving the IP protection class

- Only use cable glands in the specified clamping area.
- When using very soft cable types, do not use them in the lower clamping area.
- Only use round cables or cables with a slightly oval-shaped cross section.
- Frequent opening/closing is possible but may have a negative effect on the IP protection class.
- If cables are demonstrating pronounced cold flow behavior, the cable glands will need to be retightened.
- Cables with VA wire mesh require special cable glands.

7.3 Installation instructions

The usual way of ensuring that thermal measurements are accurate is to comply with the minimum installation length of the temperature sensor. Ideally, the sensor on a thermometer should be located in the center of the pipe.

7.3.1 Recommended installation length

To avoid heat dissipation errors.

Medium	Installation length
Fluids	8 ... 10 x Ø thermowell tip
Gases	10 ... 15 x Ø thermowell tip

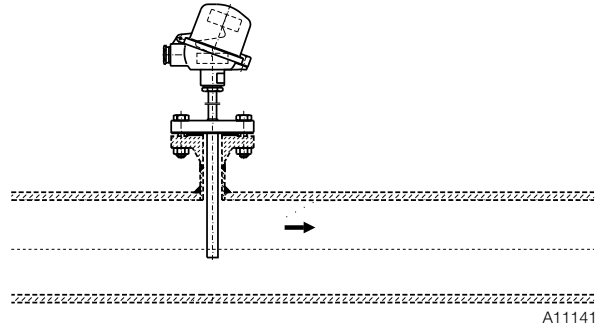

Fig. 21

7.4 Insufficient nominal diameter

In the case of pipelines with very small nominal diameters, insertion inside an elbow pipe is recommended. The temperature sensor is set in opposition to the flow direction of the medium. Inserting the temperature sensor with an adapter at an angle of $< 45^\circ$ against the flow direction can also distort measurement results.

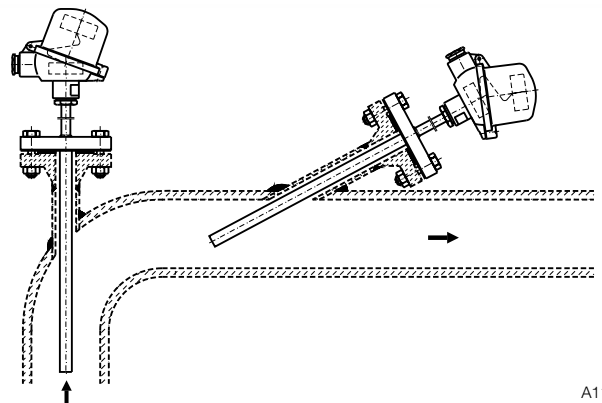

Fig. 22

7.5 Electrical connections

7.5.1 Safety instructions for electrical installation

The electrical connection may only be established by authorized specialist personnel.

The electrical connection information in this manual must be observed; otherwise, the IP rating may be adversely affected. Safe isolation of electrical circuits which are dangerous if touched is only ensured if the connected devices satisfy the requirements of DIN EN 61140 (VDE 0140 Part 1) (basic requirements for safe isolation).

To ensure safe isolation, install supply lines so that they are separate from electrical circuits which are dangerous if touched, or implement additional isolation measures for them.

7.5.2 General information

The following applies to devices with a transmitter:

The power supply and signal are routed in the same line and must be implemented as a SELV or PELV circuit in accordance with the relevant standard (standard version). For the Ex version, the guidelines stipulated by the Ex standard must be adhered to.

- The cable wires must be provided with end sleeves.
- When using PROFIBUS PA, the design must be in accordance with EN 50170 for PROFIBUS PA.
- When using FOUNDATION FOUNDATION Fieldbus H1, the design must be in accordance with IEC 61158.
- The user is responsible for ensuring EMC compliant cabling.

7.5.3 Electrical connections

Electrical connections and color coding of resistance thermometers in accordance with IEC 60751

Single sensor

2-W.

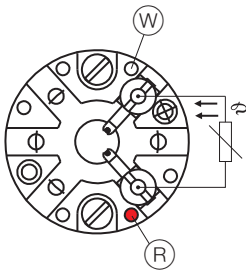

3-W.

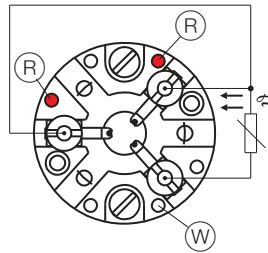

4-W.

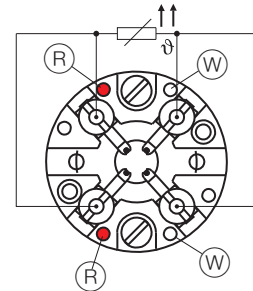

A11137

(R) Red (W) White

Electrical connections and color coding of resistance thermometers in accordance with IEC 60751

Double sensor

2-W.

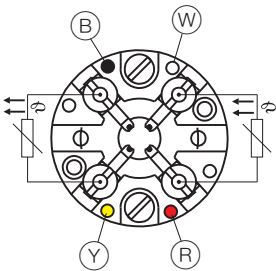

3-W.

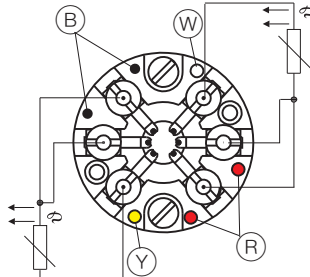

4-W.

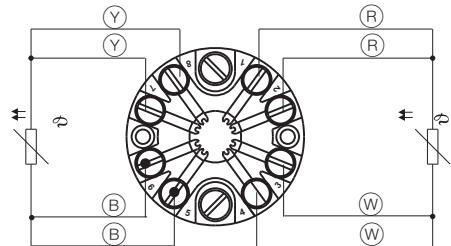

A11138

(R) Red (Y) Yellow (B) Black (W) White

Electrical connections of thermocouples in accordance with IEC 60584

Single sensor

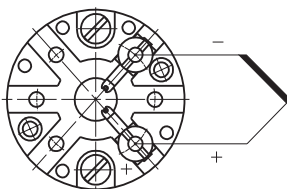

A11027

Double sensor

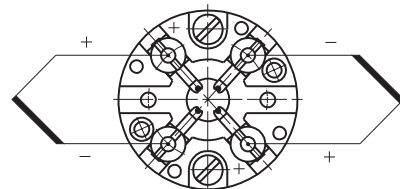

A11028

7.5.4 Harting plug connection in connection head

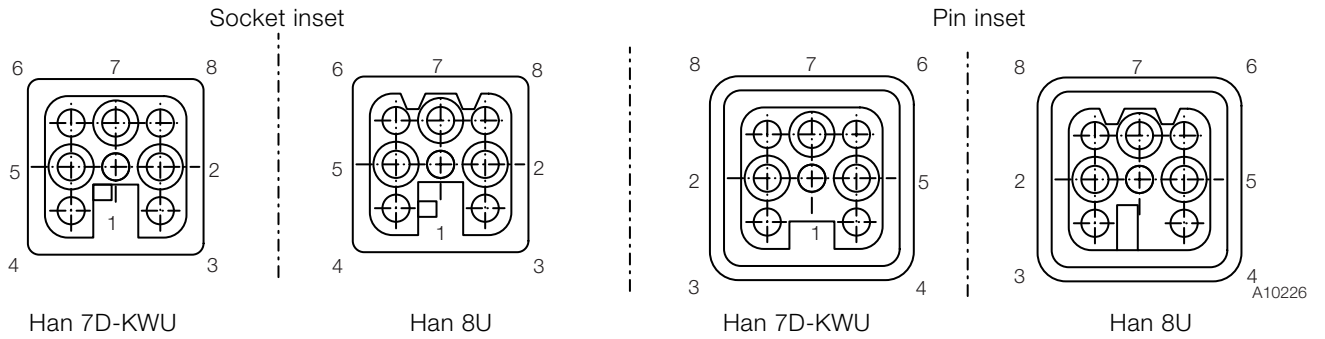

Fig. 23: External view in each case

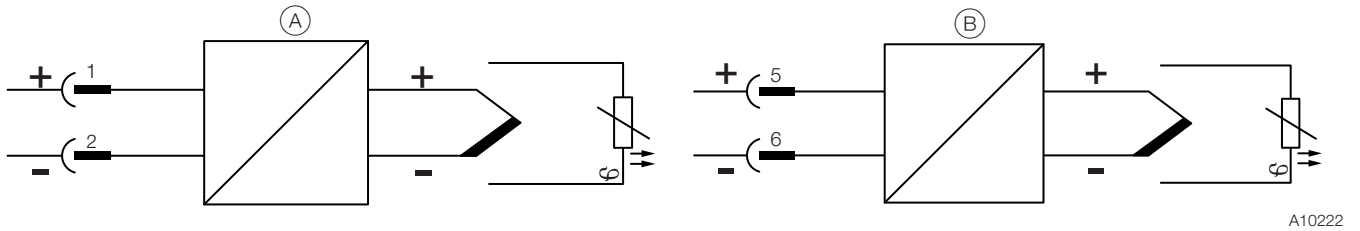
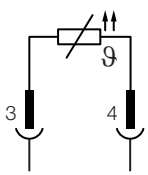

Fig. 24: With one or two transmitters in connection head

(A) One transmitter (B) Second transmitter

Two-wire circuit



Three-wire circuit

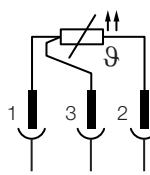

Four-wire circuit

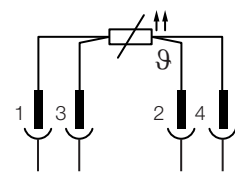

A10227

Fig. 25: Resistance thermometer as single sensor

Two-wire circuit

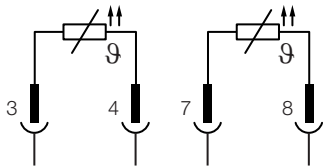

Three-wire circuit

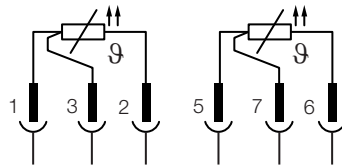

Four-wire circuit

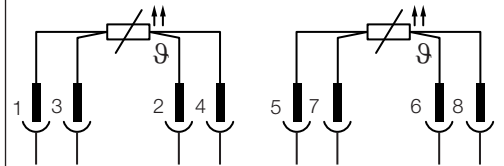

A10225

Fig. 26: Resistance thermometer as double sensor

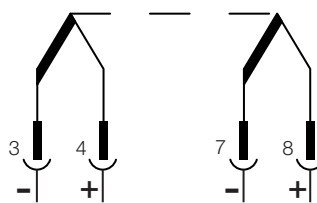
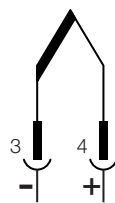

A10224

Fig. 27: Thermocouple as single sensor or double sensor

8 Commissioning

8.1 General remarks

The device is immediately ready for operation after mounting and installation of the connections. Default parameters are set at the factory.

8.2 Checks prior to commissioning

The following must be checked before commissioning:

- Thermowells and protective sleeves have been installed correctly and form a tight seal, especially when used as a separation element for Zone 0.
- The potential equalization line is connected.
- The electrical specifications comply with the specified Ex relevant values.
- Electrical connection and installation has been carried out correctly in accordance with the "Installation" and "Electrical connection" chapters.

9 Operation

9.1 Safety instructions

If there is a chance that safe operation is no longer possible, take the device out of operation and secure it against unintended startup.

⚠ CAUTION

Risk of burns due to hot measuring media.

The device surface temperature may exceed 70 °C (158 °F), depending on the measuring medium temperature! Before starting work on the device, make sure that it has cooled sufficiently.

i NOTICE

Configuration with an integrated LCD indicator is only provided for temperature sensors in the TSP1x1 and TSP3x1 series.

9.2 Menu navigation

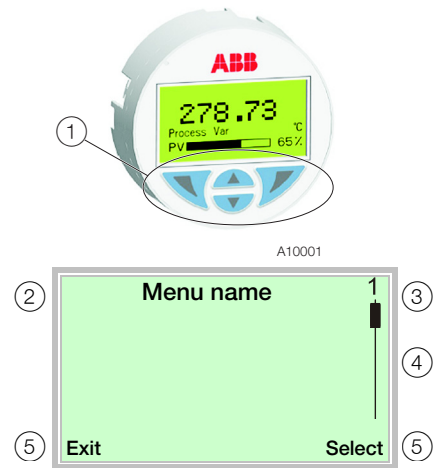







Fig. 28: LCD display (example)

- ① Operating keys to the menu navigation
- ② Display of menu name
- ③ Display of menu number
- ④ Marking for displaying the relevant positions within the menu
- ⑤ Display of current functions of the operating keys  and 

9.3 Operating button functions

You can use the  or  operating buttons to browse through the menu or select a number or character within a parameter value.

Different functions can be assigned to the  and  operating buttons. The function ⑤ that is currently assigned to them is shown on the LCD display.

Control button functions

	Meaning
Exit	Exit menu
Back	Go back one submenu
Cancel	Cancel a parameter entry
Next	Select the next position for entering numerical and alphanumeric values

	Meaning
Select	Select submenu / parameter
Edit	Edit parameter
OK	Save parameter entered

9.3.1 Process display

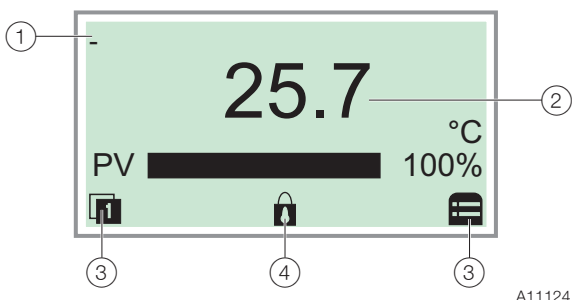







Fig. 29: Process display (example)
 ① Measuring point tagging (device TAG) ② Current process values
 ③ "Button function" symbol ④ "Parameterization protected" symbol

The process display appears on the LCD display when the device is switched on. It shows information about the device and current process values.

The way in which the current process values are shown can be adjusted on the configuration level.

The symbols at the bottom of the process display are used to indicate the functions of the operating buttons  and , in addition to other information.

Symbol	Description
	Call up information level.
	Call up configuration level.
	The device is protected against changes of the parameter settings.

Error messages on the LCD display HART

If the event of an error, a message consisting of a symbol or letter (device status) and a number (DIAG NO.) will appear at the bottom of the process display.

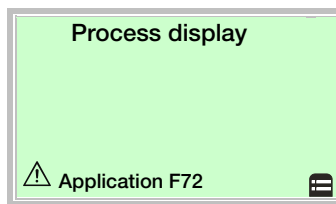

The diagnostic messages are divided into the following groups in accordance with the NAMUR classification scheme:

Symbol - Letter	Description
I	OK or Information Device is functioning or information is available
C	Check Function Device is undergoing maintenance (e. g. simulation)
S	Off Specification Device or measuring point is being operated outside of the specifications
M	Maintenance Required Request service to prevent the measuring point from failing
F	Failure Error; measuring point has failed

The error can then be read in plain-text format on the "Diagnostics" information level.

Additionally, the diagnostic messages are divided into the following areas:

Range	Description
Electronics	Diagnosis for device hardware.
Sensor	Diagnosis for sensor elements and connection lines.
Installation / Configuration	Diagnosis for communication interface and parameterization / configuration
Operating conditions	Diagnosis for ambient and process conditions.

i NOTICE



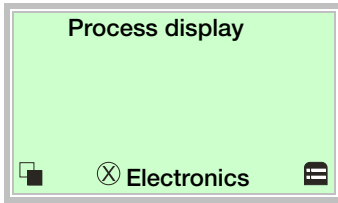

For a detailed description of the errors and information on troubleshooting, see chapter "Diagnosis / error messages" on page 27.

Error messages in the PROFIBUS PA and FOUNDATION Fieldbus LCD display

In the event of an error, a message consisting of a symbol and text appears at the bottom of the process screen (e. g. electronics). The text displayed provides information about the area in which the error has occurred.



The error messages are divided into four groups in accordance with the NAMUR classification scheme. The group assignment can only be changed using a DTM or EDD:

Symbol	Description
	Error / failure
	Function check
	Outside of the specification
	Maintenance required

The error can then be read in plain-text format on the "Diagnostics" information level.

The error messages are also divided into the following areas:

Range	Description
Electronics	Diagnosis for device hardware.
Sensor	Diagnosis for sensor elements and connection lines.
Installation / Configuration	Diagnosis for communication interface and parameterization / configuration
Operating conditions	Diagnosis for ambient and process conditions.

i NOTICE













For a detailed description of the errors and information on troubleshooting, see chapter "Diagnosis / error messages" on page 27.

9.3.2 Menu structure and diagnostic messages

The parameters are structured in the form of a menu. The menu consists of a maximum of three levels. For detailed information on the menu structure, a description of the parameters and a list of possible diagnostic messages, please consult the operating instructions for the transmitter.

9.3.3 Setting the language

The language is set to German by default in the equipment's as-delivered state. To change it to English, proceed as follows:

1. Press the  control button to call up the configuration menu.
2. Use either the  or  control button to scroll to the "Display" submenu.
3. Press the  control button to call up the "Display" submenu.
4. Use either the  or  control button to scroll to the "Language" submenu.
5. Press the  control button to call up the "Language" submenu.
6. Press the  control button to switch to Edit mode and use either the  or  control button to navigate to "English".
7. Press the  control button to switch to the language setting for English.
8. Press the  control button three times to navigate back to the display.

10 Diagnosis / error messages

10.1 Error messages

i NOTICE

For a detailed description of the errors and information on troubleshooting, see the operating manual of the transmitter.

10.2 Faults in operation

The entire temperature measurement circuit should be tested routinely. The tables below contain details of the most major faults together with their possible causes and suggestions for how to remedy them.

Failure	Cause	Remedy
Measuring signal fault	– Electrical/magnetic interference.	<ul style="list-style-type: none"> – Keep measuring wires that are laid in parallel at least 0.5 m (20 inch) apart. – Electrostatic shielding via on one point grounded foil/netting. – Twist wires (pairs) against magnetic interference. – Right angle intersecting of measurement wires with interfering power cables. – Use of transmitters.
	– Grounding error.	Only one grounding point in measurement circuit or measurement system “floating” (not grounded).
	– Decrease in the insulation resistance.	<ul style="list-style-type: none"> – Moisture has possibly penetrated into the thermometer or the measuring inset; dry if necessary and seal again. – Replace measuring inset. – Check whether the thermometer is thermally overloaded.
Response times too long, incorrect signals	Incorrect installation location: – In the flow shadow – In the influence of a heat source	Select installation location so that the medium can transfer its temperature undisturbed.
	Incorrect installation method: – Insufficient immersion length – Too much heat dissipation	<ul style="list-style-type: none"> – Immersion length approx. temperature sensitive length + 6 x d (fluids) to 10 x (gases) d (d = outer thermowell diameter). – Ensure thermal contacts, above all with surface measurements, through appropriate contact surfaces and/or thermal conducting material.
	– Thermowell too thick – Thermowell hole too large	<ul style="list-style-type: none"> – Select the smallest thermowell possible for the process. – Initial approximation of response time proportional to the cross section or volume of the thermometer, depending on the heat transfer values and air gaps in the structure. – The latter with heat-conductive paste.
	– Deposits on the thermowell	<ul style="list-style-type: none"> – Remove during inspections. – If possible, select a different thermowell or another installation location.
Interruptions in the thermometer	Vibrations	<ul style="list-style-type: none"> – Reinforced springs on the measuring inset. – Reduce the installation length. – Relocation of the measuring point (if possible). – Special measuring inset and thermowell structure.
Heavily corroded thermowell	<ul style="list-style-type: none"> – Composition of the medium not as assumed or changed – Improper thermowell material selected 	<ul style="list-style-type: none"> – Check medium. – Possibly analyze the defective thermowell and then select a more suitable material. – Use additional surface protection. – Under certain circumstances, the thermowell may have to be replaced regularly as a wear part.

10.2.1 Specific faults with thermocouples

Failure	Cause	Remedy
Fluctuating temperature indication with otherwise problem-free thermocouple measurement circuit structure	Reference points - temperature or voltage not constant	<ul style="list-style-type: none"> – Temperature or supply voltage must remain constant. – Full value incorporated into measurements for non-precious metal thermocouples; only approx. half the value incorporated for precious metal thermocouples.
Temperature display values deviate significantly from table values for thermocouples	<ul style="list-style-type: none"> – Incorrect material combinations – Poor electrical contacts – Parasitic voltages (thermoelectric voltages, electrical voltages) – Incorrect compensating cable 	<ul style="list-style-type: none"> – Check thermocouples and wires for: <ul style="list-style-type: none"> – Correct pairing. – Correct compensating cable. – Correct polarity. – Permissible ambient temperature at connection head.

10.2.2 Specific faults with resistance thermometers

Failure	Cause	Remedy
Too high or fluctuating temperature display despite known cross section and precision measurement resistor for resistance thermometer	<ul style="list-style-type: none"> – Line resistances too high, not compensated – Temperature-related resistance change in connection lead 	<p>If still possible:</p> <ul style="list-style-type: none"> – Running of 2 lines or larger cross section possibly only after a more accessible location. – Shorten the connection lead. – Connection lead compensation. – Switch to three- or four-wire circuit. – Use of head-mount transmitters.
Fluctuating temperature display with otherwise problem-free resistance thermometer measurement circuit structure	<ul style="list-style-type: none"> – Voltage or power supply not constant 	<ul style="list-style-type: none"> – Must be kept constant at < 0.1%. Full value used for measurement with out-of-tune bridges and current / voltage measurement (four-wire circuit).

11 Repair

Repair and maintenance activities may only be performed by authorized customer service personnel.

When replacing or repairing individual components, use original spare parts.

11.1 Returning devices

Use the original packaging or a secure transport container of an appropriate type if you need to return the device for repair or recalibration purposes. Fill out the return form (see the Appendix) and include this with the device.

According to the EU Directive governing hazardous materials, the owner of hazardous waste is responsible for its disposal or must observe the following regulations for shipping purposes: All devices delivered to ABB must be free from any hazardous materials (acids, alkalis, solvents, etc.).

Please contact Customer Center Service acc. to page 2 for nearest service location.

12 Recycling and disposal

12.1 Disposal

I NOTICE



Products that are marked with this symbol may not be disposed of through municipal garbage collection points.

This product and its packaging are manufactured from materials that can be recycled by specialist recycling companies.

Bear the following points in mind when disposing of them:

- This product is not subject to WEEE Directive 2002/96/EC or relevant national laws (e.g. ElektroG in Germany).
- The product must be surrendered to a specialist recycling company. Do not use municipal garbage collection points. According to WEEE Directive 2002/96/EC, only products used in private applications may be disposed of at municipal garbage collection points.
- If it is not possible to dispose of old equipment properly, ABB Service can take receipt of and dispose of returns for a fee.

12.2 Information on ROHS Directive 2011/65/EC

The products provided by ABB Automation Products GmbH do not fall within the current scope of regulations on hazardous substances with restricted uses or the directive on waste electrical and electronic equipment according to ElektroG.

If the necessary components are available on the market at the right time, in the future these substances will no longer be used in new product development.

13 Spare parts, consumables and accessories

Repair and maintenance activities may only be performed by authorized customer service personnel.

When replacing or repairing individual components, use original spare parts.

14 Specifications

i NOTICE

The detailed device data sheet is available in the download area at www.abb.com/temperature.

15 Declaration of conformity

i NOTICE

Declarations of conformity of the device are available in the download center of ABB at www.abb.com/temperature.

They are additionally enclosed with the device for ATEX certified devices.

Trademarks

® HART is a registered trademark of FieldComm Group, Austin, Texas, USA

® PROFIBUS and PROFIBUS PA are registered trademarks of PROFIBUS & PROFINET International (PI)

® FOUNDATION Fieldbus is a registered trademark of FieldComm Group, Austin, Texas, USA

16 Appendix

16.1 Return form

Statement on the contamination of devices and components

Repair and / or maintenance work will only be performed on devices and components if a statement form has been completed and submitted.

Otherwise, the device / component returned may be rejected. This statement form may only be completed and signed by authorized specialist personnel employed by the operator.

Customer details:

Company: _____
Address: _____
Contact person: _____ Telephone: _____
Fax: _____ E-Mail: _____

Device details:

Typ: _____ Serial no.: _____
Reason for the return/description of the defect: _____

Was this device used in conjunction with substances which pose a threat or risk to health?

Yes No

If yes, which type of contamination (please place an X next to the applicable items)?

Biological	<input type="checkbox"/>	Corrosive / irritating	<input type="checkbox"/>	Combustible (highly / extremely combustible)	<input type="checkbox"/>
Toxic	<input type="checkbox"/>	Explosiv	<input type="checkbox"/>	Other toxic substances	<input type="checkbox"/>
Radioactive	<input type="checkbox"/>				

Which substances have come into contact with the device?

1. _____
2. _____
3. _____

We hereby state that the devices / components shipped have been cleaned and are free from any dangerous or poisonous substances.

Town/city, date Signature and company stamp

Contact us

ABB Limited

Process Automation

Howard Road, St. Neots
Cambridgeshire, PE19 8EU
UK

Tel: +44 (0)870 600 6122

Fax: +44 (0)1480 213 339

Mail: enquiries.mp.uk@gb.abb.com

ABB Inc.

Process Automation

125 E. County Line Road
Warminster, PA 18974
USA

Tel: +1 215 674 6000

Fax: +1 215 674 7183

ABB Automation Products GmbH

Process Automation

Schillerstr. 72
32425 Minden
Germany

Tel: +49 571 830-0

Fax: +49 571 830-1806

www.abb.com/temperature

Note

We reserve the right to make technical changes or modify the contents of this document without prior notice.

With regard to purchase orders, the agreed particulars shall prevail. ABB does not accept any responsibility whatsoever for potential errors or possible lack of information in this document.

We reserve all rights in this document and in the subject matter and illustrations contained therein. Any reproduction, disclosure to third parties or utilization of its contents – in whole or in parts – is forbidden without prior written consent of ABB.

Copyright© 2016 ABB

All rights reserved

3KXT161001R4201

Original instruction