



## Product Information

### Ultrasonic

Level measurement in liquids and bulk solids

VEGASON 61, 62, 63

# VEGA

## Contents

1	Measuring principle	3
2	Type overview	4
3	Instrument selection	5
4	Selection criteria	6
5	Housing overview	7
6	Mounting	8
7	Electronics - 4 ... 20 mA/HART - two-wire	9
8	Electronics - 4 ... 20 mA/HART - four-wire	10
9	Electronics - Profibus PA	11
10	Electronics - Foundation Fieldbus	12
11	Operation	13
12	Dimensions	14

### Take note of safety instructions for Ex applications



Please note the Ex specific safety information which you can find on our homepage [www.vega.com/downloads](http://www.vega.com/downloads) and "Approvals" and which comes with every instrument. In hazardous areas you should take note of the corresponding regulations, conformity and type approval certificates of the sensors and power supply units. The sensors must only be operated on intrinsically safe circuits. The permissible electrical values are stated in the certificate.

# 1 Measuring principle

## Measuring principle

Short ultrasonic pulses in the range of 10 to 70 kHz are emitted by the transducer in the direction of the product, reflected by its surface and received back by the transducer. The pulses travel at the speed of sound. The elapsed time from emission to reception of the signals is proportional to the level in the vessel. The proven ECHOFOX signal processing filters the correct level echo out of a number of interfering reflections. An adjustment with empty and full vessel is not necessary.

## Applications in liquids

Sensors with frequencies between 30 and 70 kHz are used for measurement in liquids. They operate independently of product properties and are ideal for the water/waste water industry and for the measurement of weak acids and alkaline solutions. Gas-Ex applications can also be equipped with these sensors.

## Input variable

The reference plane for the measurement is the lower edge of the transducer. All statements concerning the measuring range as well as the internal signal processing refer to this.

With all instruments a minimum distance from the lower edge of the flange - the so-called dead band, in which measurement is not possible - must be maintained. You can find the exact value of the dead band in the operating instructions manual of the respective instrument.

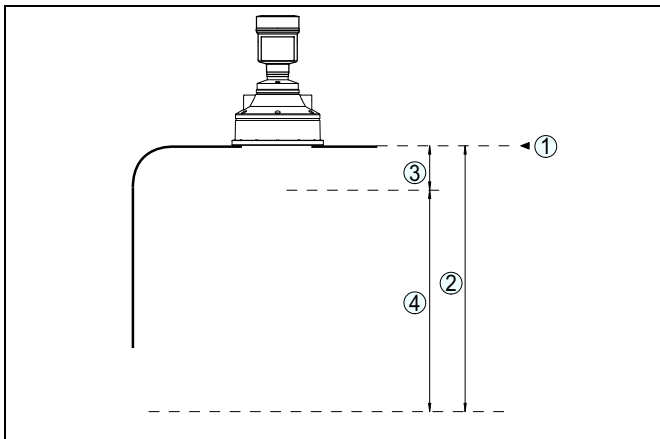

Fig. 1: Data of the input variable with VEGASON 63

- 1 Reference plane
- 2 Max. measuring range
- 3 Dead band
- 4 Useful measuring range

## 2 Type overview

**VEGASON 61**

**VEGASON 62**

**VEGASON 63**

<b>Applications</b>	Liquids in storage vessels or open basins as well as flow measurements in open flumes. Also detection of bulk solids	Liquids in average-size storage vessels or open basins. Also detection of bulk solids	Measurement of liquids in average-size storage vessels or open basins. Also detection of bulk solids
<b>Max. measuring range</b>	In liquids: 5 m (16.4 ft) In bulk solids: 2 m (6.562 ft)	In liquids: 8 m (26.25 ft) In bulk solids: 3.5 m (11.48 ft)	In liquids: 15 m (49.21 ft) In bulk solids: 7 m (22.97 ft)
<b>Material transducer</b>	PVDF	PVDF	UP/316 Ti
<b>Material process fitting</b>	PVDF	PVDF	UP
<b>Process temperature</b>	-40 ... +80 °C (-40 ... +176 °F)	-40 ... +80 °C (-40 ... +176 °F)	-40 ... +80 °C (-40 ... +176 °F)
<b>Process pressure</b>	-0.2 ... +2 bar/-20 ... +200 kPa (-2.9 ... +29 psig)	-0.2 ... +2 bar/-20 ... +200 kPa (-2.9 ... +29 psig)	-0.2 ... +1 bar/-20 ... +100 kPa (-2.9 ... +14.5 psig)
<b>Deviation</b>	±4 mm or < 0.2 %	±4 mm or < 0.2 %	±6 mm or < 0.2 %
<b>Signal output</b>	<ul style="list-style-type: none"> <li>• 4 ... 20 mA/HART two-wire</li> <li>• 4 ... 20 mA/HART - four-wire</li> <li>• Profibus PA</li> <li>• Foundation Fieldbus</li> </ul>	<ul style="list-style-type: none"> <li>• 4 ... 20 mA/HART two-wire</li> <li>• 4 ... 20 mA/HART - four-wire</li> <li>• Profibus PA</li> <li>• Foundation Fieldbus</li> </ul>	<ul style="list-style-type: none"> <li>• 4 ... 20 mA/HART two-wire</li> <li>• 4 ... 20 mA/HART - four-wire</li> <li>• Profibus PA</li> <li>• Foundation Fieldbus</li> </ul>
<b>Indication/Adjustment</b>	<ul style="list-style-type: none"> <li>• PLICSCOM</li> <li>• PACTware</li> <li>• VEGADIS 61</li> <li>• VEGADIS 62</li> </ul>	<ul style="list-style-type: none"> <li>• PLICSCOM</li> <li>• PACTware</li> <li>• VEGADIS 61</li> <li>• VEGADIS 62</li> </ul>	<ul style="list-style-type: none"> <li>• PLICSCOM</li> <li>• PACTware</li> <li>• VEGADIS 61</li> <li>• VEGADIS 62</li> </ul>
<b>Approvals</b>	<ul style="list-style-type: none"> <li>• ATEX</li> <li>• IEC</li> <li>• Shipbuilding</li> <li>• FM</li> <li>• CSA</li> <li>• Gost</li> </ul>	<ul style="list-style-type: none"> <li>• ATEX</li> <li>• IEC</li> <li>• Shipbuilding</li> <li>• FM</li> <li>• CSA</li> <li>• Gost</li> </ul>	<ul style="list-style-type: none"> <li>• Shipbuilding</li> </ul>

### 3 Instrument selection

#### Application areas

##### VEGASON 61

The VEGASON 61 is suitable for level measurement of liquids and for use in small bulk solids vessels. Typical applications are the measurement of liquids in storage vessels or open basins as well as flow measurements in open flumes.

The sensor is also suitable for detection of bulk solids.

##### VEGASON 62

The VEGASON 62 is suitable for level measurement of liquids and for use in small bulk solids vessels. Typical applications are the measurement of liquids in average-size storage vessels or open basins.

The sensor is also suitable for detection of bulk solids.

##### VEGASON 63

The VEGASON 63 is suitable for level measurement in liquids and bulk solids in all industries. Typical applications are the measurement in liquids in average-size storage vessels or open basins.

The sensor is also suitable for detection of bulk solids. The max. measuring range depends on the dust generation and consistency of the bulk solid.

#### Applications

##### Level measurement in vessels

For level measurement in vessels with conical bottom it can be advantageous to mount the sensor in the center of the vessel, as measurement is then possible down to the lowest point of the vessel bottom.

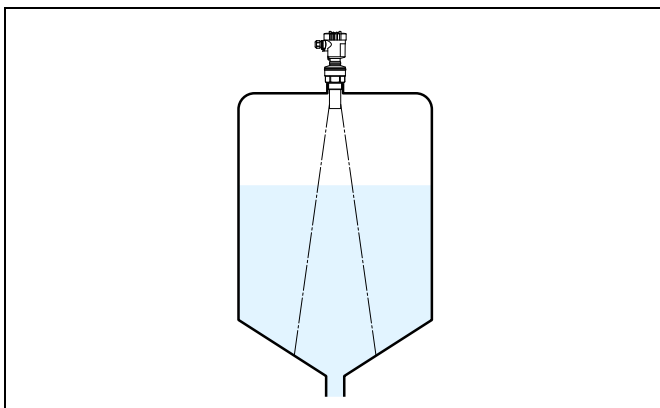

Fig. 2: Level measurement in vessels with conical bottom

##### Level measurement in a standpipe

When used in a standpipe (surge or bypass tube), the influence of vessel installations, foam generation and turbulence is excluded. Standpipes must reach down to the requested min. level because measurement is only possible within the tube.

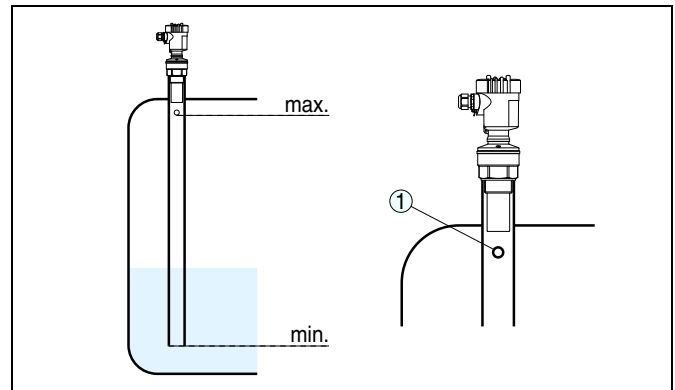

Fig. 3: Standpipe in the tank

1 Vent hole:  $\varnothing$  5 ... 10 mm (0.197 ... 0.394 in)

##### Level measurement in basins

To reduce the min. distance to the medium, you can also mount the VEGASON with a beam deflector. By doing this, it is possible to fill the vessel nearly to maximum. Such an arrangement is suitable primarily for open vessels such as e.g. overflow basins.

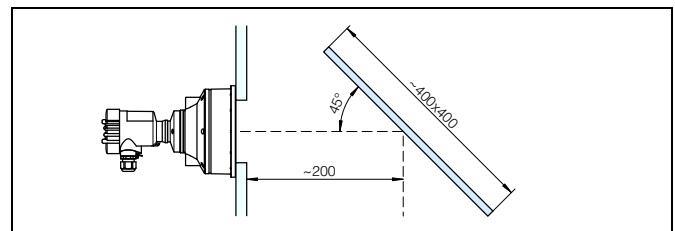





Fig. 4: VEGASON 63 with beam deflector



## 4 Selection criteria

		VEGASON 61	VEGASON 62	VEGASON 63
<b>Vessel</b>	Small vessels	●	●	●
	Average-size vessels	–	●	●
	Open basins	●	●	●
<b>Process</b>	Flow measurement	●	●	–
	Aggressive products	●	●	–
<b>Installation</b>	Threaded fittings	●	●	–
	Flange connections	●	●	●
	Hygienic fittings	●	●	–
	Mounting bracket	–	–	●
<b>Transducer</b>	Measurement in a by-pass tube or surge pipe	●	●	●
<b>Suitability for industry-specific applications</b>	Offshore	●	●	●
	Shipbuilding	●	●	●
	Water and waste water industry	●	●	●

## 5 Housing overview

<b>Plastic PBT</b>		
<b>Protection rating</b>	IP 66/IP 67	IP 66/IP 67
<b>Version</b>	Single chamber	Double chamber
<b>Application area</b>	Industrial environment	Industrial environment

<b>Aluminium</b>		
<b>Protection rating</b>	IP 66/IP 67, IP 66/IP 68 (1 bar)	IP 66/IP 67, IP 66/IP 68 (1 bar)
<b>Version</b>	Single chamber	Double chamber
<b>Application area</b>	Industrial environment with increased mechanical wear	Industrial environment with increased mechanical wear

<b>Stainless steel 316L</b>			
<b>Protection rating</b>	IP 66/IP 67	IP 66/IP 67, IP 66/IP 68 (1 bar)	IP 66/IP 67, IP 66/IP 68 (1 bar)
<b>Version</b>	Single chamber electropolished	Single chamber precision casting	Double chamber precision casting
<b>Application area</b>	Aggressive environment, food processing, pharmaceutical	Aggressive environment, strong mechanical wear	Aggressive environment, strong mechanical wear

## 6 Mounting

### Mounting examples

The following illustrations show mounting examples and measurement setups.

determines the loading height of the conveyor belt. By means of the mounting strap, the VEGASON 63 can be optimally oriented to the medium.

#### Waste water tank

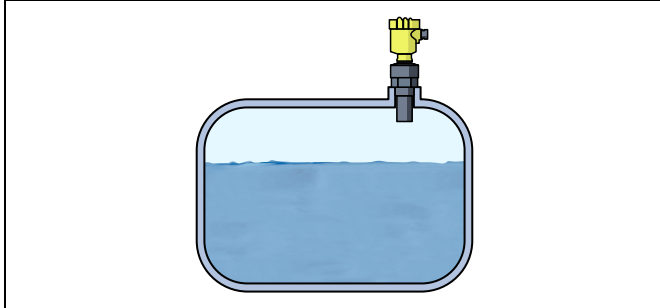

Fig. 5: Level measurement in the waste water tank with VEGASON 61

Due to the solid components and the varying density of the tank contents, non-contact level measurement with ultrasonics is the most suitable method here. The PVDF-encapsulated transducer of VEGASON 61 is resistant against aggressive gases in the tank and requires only a G1½ A mounting boss as process fitting.

#### Pump shaft

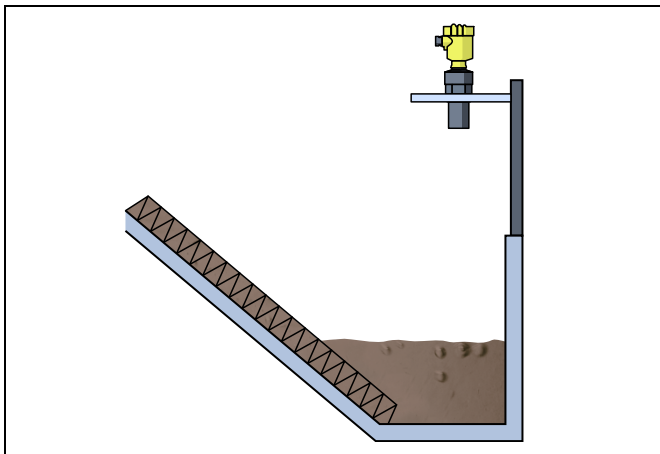

Fig. 6: Level measurement in a pump shaft with VEGASON 62

For simple applications in pump shafts, the contactless ultrasonic sensor VEGASON 62 is used. Independent of the waste water consistency it measures the level without maintenance.

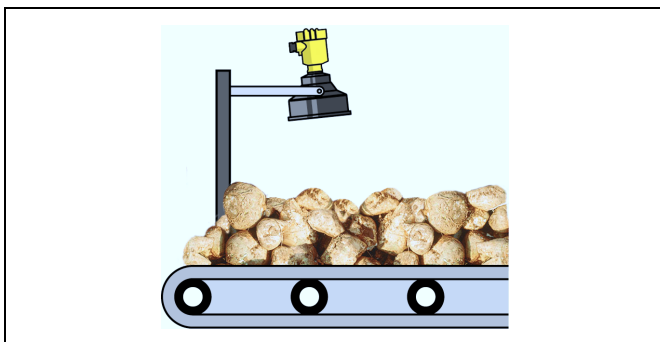

Fig. 7: Profile measurement on a conveyor belt with VEGASON 63

The contactlessly measuring ultrasonic sensor VEGASON 63 is an economical solution for profile monitoring, for example of sugar beets. The ultrasonic waves are reflected by the medium, the integrated electronics



## 7 Electronics - 4 ... 20 mA/HART - two-wire

### Configuration of the electronics

The pluggable electronics is mounted in the electronics compartment of the instrument and can be exchanged by the user when servicing is required. The electronics is completely encapsulated to protect against vibration and moisture.

The terminals for voltage supply as well as contact pins with I<sup>2</sup>C interface for parameter adjustment are located on the upper side of the electronics. With the double chamber housing, the terminals are located in the separate connection compartment.

### Voltage supply

Depending on the version, the supply voltage and the current signal are carried on the same two-wire connection cable.

The VEGA power supply units VEGATRENN 149AEx, VEGASTAB 690, VEGADIS 371 as well as VEGAMET signal conditioning instruments are suitable for power supply. When one of these instruments is used, a reliable separation of the supply circuits from the mains circuits according to DIN VDE 0106 part 101 is ensured for the sensor.

- Operating voltage
  - 14 ... 36 V DC
- Permissible residual ripple
  - $U_{pp} < 1 \text{ V}$  (< 100 Hz)
  - $U_{pp} < 10 \text{ mV}$  (100 ... 10 kHz)

### Connection cable

The sensors are connected with standard cable without screen. An outer cable diameter of 5 ... 9 mm ensures the seal effect of the cable entry.

If electromagnetic interference is expected which is above the test values of EN 61326 for industrial areas, screened cable should be used. In HART multidrop mode the use of screened cable is generally recommended.

### Cable screening and grounding

If screened cable is necessary, the cable screen must be connected on both ends to ground potential. If potential equalisation currents are expected, the connection on the evaluation side must be made via a ceramic capacitor (e.g. 1 nF, 1500 V).

### Connection single chamber housing

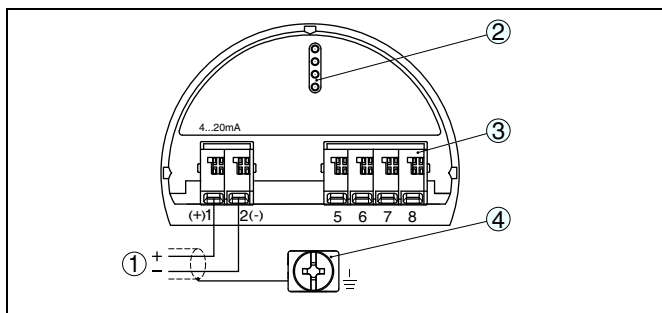

Fig. 8: Electronics and connection compartment, single chamber housing

- 1 Voltage supply/Signal output
- 2 For display and adjustment module or interface adapter
- 3 For external display and adjustment unit
- 4 Ground terminal for connection of the cable screen

### Connection, double chamber housing

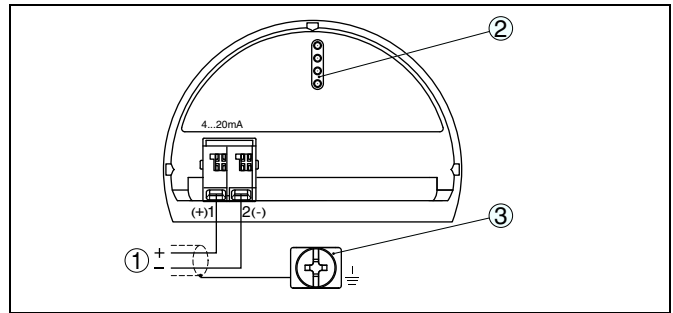

Fig. 9: Connection compartment, double chamber housing

- 1 Voltage supply/Signal output
- 2 For display and adjustment module or interface adapter
- 3 Ground terminal for connection of the cable screen

## 8 Electronics - 4 ... 20 mA/HART - four-wire

### Configuration of the electronics

The pluggable electronics is mounted in the electronics compartment of the instrument and can be exchanged by the user when servicing is required. The electronics is completely encapsulated to protect against vibration and moisture.

The terminals for voltage supply as well as contact pins with I<sup>2</sup>C interface for parameter adjustment are located on the upper side of the electronics. With the double chamber housing, the terminals are located in the separate connection compartment.

### Voltage supply

If a reliable separation is required, the power supply and the current output are transmitted over separate two-wire connection cables.

- Operating voltage
  - 20 ... 72 V DC, 20 ... 253 V AC, 50/60 Hz

### Connection cable

The 4 ... 20 mA current output is connected with standard two-wire cable without screen. If electromagnetic interference is expected which is above the test values of EN 61326 for industrial areas, screened cable should be used.

For power supply, an approved installation cable with PE conductor is required.

An outer cable diameter of 5 ... 9 mm ensures the seal effect of the respective cable entry.

### Cable screening and grounding

If screened cable is necessary, the cable screen must be connected on both ends to ground potential. If potential equalisation currents are expected, the connection on the evaluation side must be made via a ceramic capacitor (e.g. 1 nF, 1500 V).

### Connection, double chamber housing

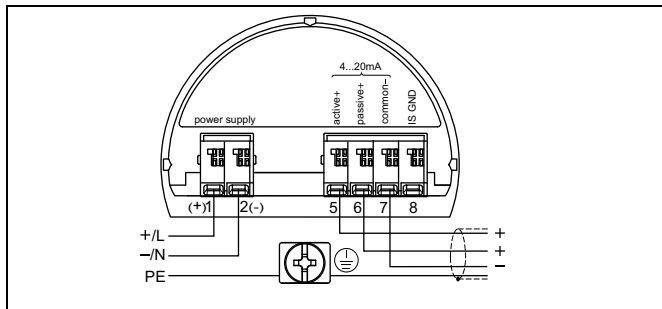

Fig. 10: Connection compartment, double chamber housing

- 1 Voltage supply
- 2 4 ... 20 mA signal output active
- 3 4 ... 20 mA signal output passive

## 9 Electronics - Profibus PA

### Configuration of the electronics

The pluggable electronics is mounted in the electronics compartment of the instrument and can be exchanged by the user when servicing is required. The electronics is completely encapsulated to protect against vibration and moisture.

The terminals for voltage supply as well as the plug with I<sup>2</sup>C interface for parameter adjustment are located on the upper side of the electronics. On the double chamber housing, these connection elements are located in the separate connection compartment.

### Voltage supply

Power supply via the H1 Fieldbus cable.

- Operating voltage
  - 9 ... 32 V DC
- Max. number of sensors with DP/PA segment coupler
  - 32
- Max. number of sensors with VEGALOG 571 EP input card
  - 10

### Connection cable

Connection is made with screened cable according to Profibus specification. A cable diameter of 5 ... 9 mm ensures the seal effect of the cable gland.

Make sure that the entire installation is carried out according to the Profibus specification. In particular, make sure that the bus is terminated with suitable terminating resistors.

### Cable screening and grounding

With systems with potential equalisation, connect the cable screen directly to ground potential at the power supply unit, in the connection box and at the sensor. The screen in the sensor must be connected directly to the internal ground terminal. The ground terminal outside on the housing must be connected to the potential equalisation (low impedance).

In systems without potential equalisation, connect the cable screen directly to ground potential at the power supply unit and at the sensor. In the connection box or T-distributor, the screen of the short stub to the sensor must not be connected to ground potential or to another cable screen. The cable screens to the power supply unit and to the next distributor must be connected to each other and also connected to ground potential via a ceramic capacitor (e.g. 1 nF, 1500 V). The low frequency potential equalisation currents are thus suppressed, but the protective effect against high frequency interference signals remains.

### Connection single chamber housing

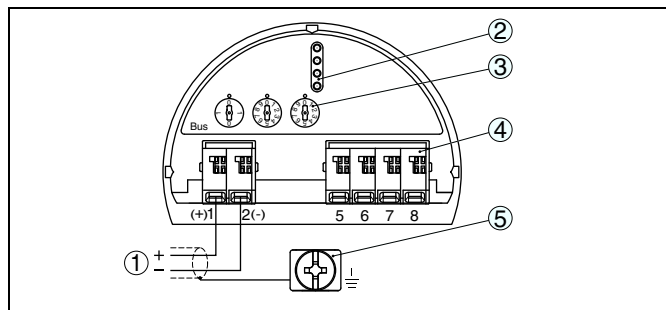

Fig. 11: Electronics and connection compartment, single chamber housing

- 1 Voltage supply/Signal output
- 2 For display and adjustment module or interface adapter
- 3 Selection switch for bus address
- 4 For external display and adjustment unit
- 5 Ground terminal for connection of the cable screen

### Connection, double chamber housing

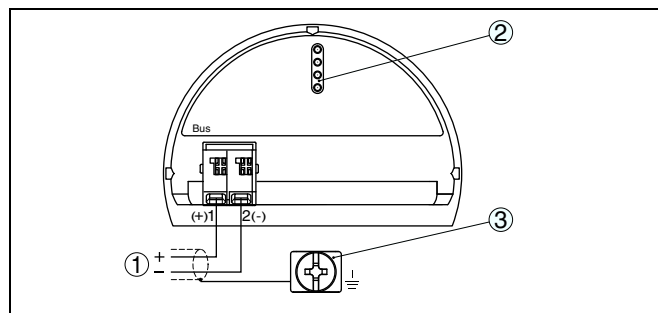

Fig. 12: Connection compartment, double chamber housing

- 1 Voltage supply/Signal output
- 2 For display and adjustment module or interface adapter
- 3 Ground terminal for connection of the cable screen

### Wire assignment connection cable VEGAPULS WL 61

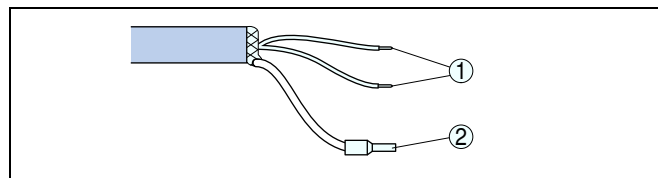

Fig. 13: Wire assignment fix-connected connection cable

- 1 brown (+) and blue (-) to power supply or to the processing system
- 2 Shielding

## 10 Electronics - Foundation Fieldbus

### Configuration of the electronics

The pluggable electronics is mounted in the electronics compartment of the instrument and can be exchanged by the user when servicing is required. The electronics is completely encapsulated to protect against vibration and moisture.

The terminals for voltage supply as well as the plug with I<sup>2</sup>C interface for parameter adjustment are located on the upper side of the electronics. On the double chamber housing, these connection elements are located in the separate connection compartment.

### Voltage supply

Power supply via the H1 Fieldbus cable.

- Operating voltage
  - 9 ... 32 V DC
- max. number of sensors
  - 32

### Connection cable

Connection is made with screened cable according to Fieldbus specification. A cable diameter of 5 ... 9 mm ensures the seal effect of the cable gland.

Make sure that the entire installation is carried out according to the Fieldbus specification. In particular, make sure that the bus is terminated with suitable terminating resistors.

### Cable screening and grounding

With systems with potential equalisation, connect the cable screen directly to ground potential at the power supply unit, in the connection box and at the sensor. The screen in the sensor must be connected directly to the internal ground terminal. The ground terminal outside on the housing must be connected to the potential equalisation (low impedance).

In systems without potential equalisation, connect the cable screen directly to ground potential at the power supply unit and at the sensor. In the connection box or T-distributor, the screen of the short stub to the sensor must not be connected to ground potential or to another cable screen. The cable screens to the power supply unit and to the next distributor must be connected to each other and also connected to ground potential via a ceramic capacitor (e.g. 1 nF, 1500 V). The low frequency potential equalisation currents are thus suppressed, but the protective effect against high frequency interference signals remains.

### Connection single chamber housing

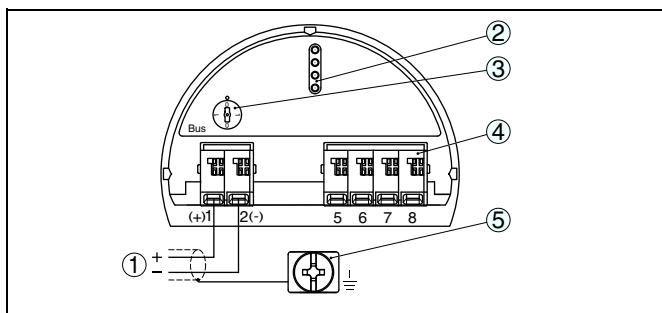

Fig. 14: Electronics and connection compartment, single chamber housing

- 1 Voltage supply/Signal output
- 2 Contact pins for the display and adjustment module or interface adapter
- 3 Selection switch for bus address
- 4 For external display and adjustment unit
- 5 Ground terminal for connection of the cable screen

### Connection, double chamber housing

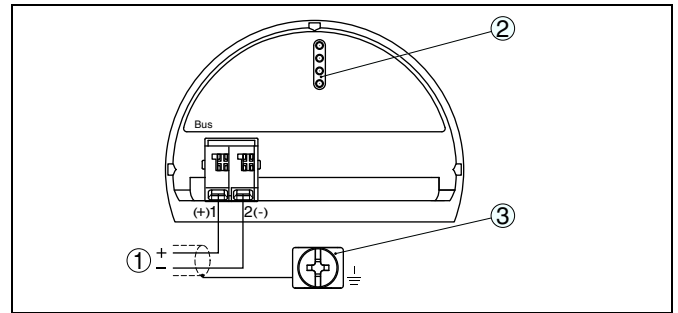

Fig. 15: Connection compartment, double chamber housing

- 1 Voltage supply/Signal output
- 2 For display and adjustment module or interface adapter
- 3 Ground terminal for connection of the cable screen

### Wire assignment connection cable VEGAPULS WL 61

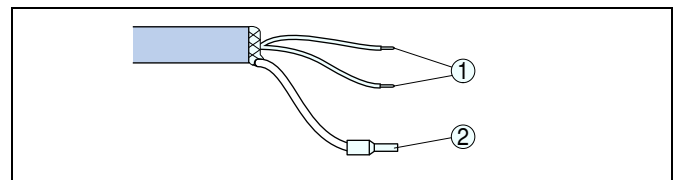

Fig. 16: Wire assignment fix-connected connection cable

- 1 brown (+) and blue (-) to power supply or to the processing system
- 2 Shielding

## 11 Operation

### 11.1 Overview

The sensors can be adjusted with the following adjustment media:

- With the display and adjustment module
- With external display and adjustment unit
- An adjustment software according to FDT/DTM standard, e.g. PACTware and PC

as well as via systems from other manufacturers, dependent on the signal output:

- A HART handheld (4 ... 20 mA/HART)
- The adjustment program AMS (4 ... 20 mA/HART and Foundation Fieldbus)
- The adjustment program PDM (Profibus PA)
- A configuration tool (Foundation Fieldbus)

The entered parameters are generally saved in the sensor, optionally also in the display and adjustment module or in the adjustment program.

### 11.2 External display and adjustment unit VEGADIS 62

VEGADIS 62 is suitable for measured value indication and adjustment of sensors with HART protocol. The instrument is looped into the 4 ... 20 mA/HART signal cable.



Fig. 17: External display and adjustment unit VEGADIS 62

### 11.3 Display and adjustment module PLICSCOM

The pluggable display and adjustment module is used for measured value indication, operation and diagnosis. It is equipped with an illuminated full dot matrix as well as four keys for adjustment.



Fig. 18: Display and adjustment module PLICSCOM

The display and adjustment module is integrated in the respective sensor housing or in the external indicating and adjustment unit. After mounting, the sensor as well as the display and adjustment module are splash-proof even without housing cover.

### 11.4 PACTware/DTM

As an alternative to the display and adjustment module, the sensor can also be configured via a Windows PC. To do this, the configuration software PACTware and a suitable instrument driver (DTM) according to the FDT standard are required. The current PACTware version as well as all available DTMs are compiled in a DTM Collection. The DTMs can also be integrated into other frame applications according to the FDT standard.

All device DTMs are available as a free-of-charge standard version and as a full version that must be purchased. In the standard version, all functions for complete setup are already included. An assistant for simple project configuration simplifies the adjustment considerably. Saving/printing the project as well as import/export functions are also part of the standard version.

In the full version there is also an extended print function for complete project documentation as well as a save function for measured value and echo curves. In addition, there is a tank calculation program as well as a multiviewer for display and analysis of the saved measured value and echo curves.

#### Connection of the PC via VEGACONNECT

The interface converter VEGACONNECT is required for connection of the PC. On the computer side, the connection is made via USB interface. The VEGACONNECT is placed instead of the display and adjustment module to the sensor, the connection to the sensor is made automatically. As an alternative the connection via the HART signal can be carried out on any position of the signal cable with 4 ... 20 mA/HART sensors.

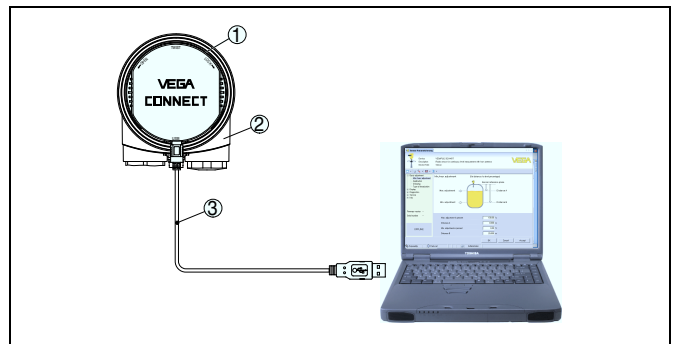

Fig. 19: Connection via VEGACONNECT and USB

- 1 VEGACONNECT
- 2 plics<sup>®</sup> sensor
- 3 USB cable to the PC

Necessary components:

- VEGASON
- PC with PACTware and suitable DTM
- VEGACONNECT
- Voltage supply/Processing system

### 11.5 Alternative adjustment programs

#### PDM

For HART and Profibus PA sensors, device descriptions are available as EDDs for the adjustment program PDM. The device descriptions are already included in the current version of the PDM. Newer instrument drivers that are not yet delivered with the PDM are available in the download section.

#### AMS

For HART and Foundation Fieldbus sensors, device descriptions are available as EDDs for the adjustment program AMS. The device descriptions are already included in the current version of the AMS. Newer instrument drivers that are not yet delivered with the AMS are available in the download section.

## 12 Dimensions

### Plastic housing

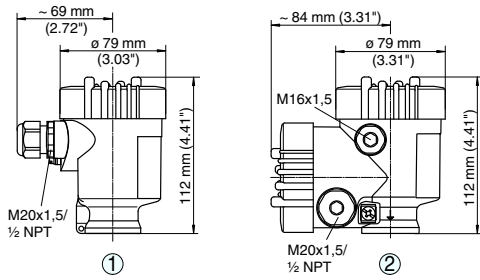

- 1 Single chamber housing
- 2 Double chamber housing

### Aluminium housing

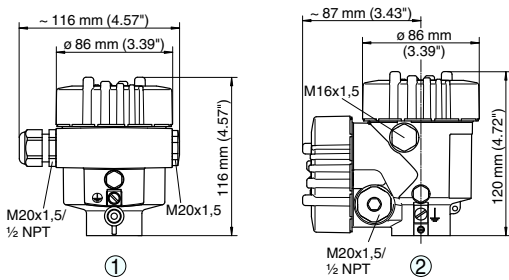

- 1 Single chamber housing
- 2 Double chamber housing

### Stainless steel housing

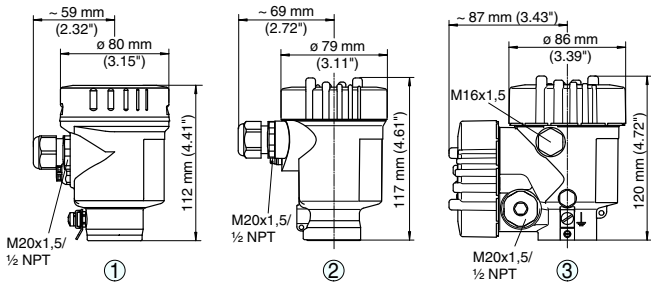

- 1 Single chamber housing electropolished
- 2 Single chamber housing precision casting
- 2 Double chamber housing precision casting

### VEGASON 61

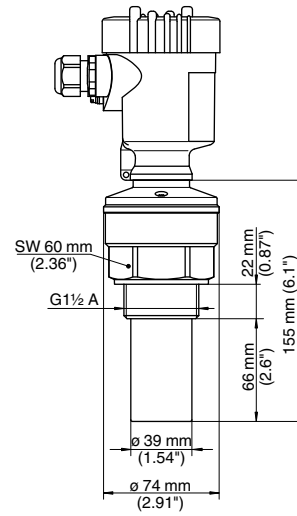

### VEGASON 62

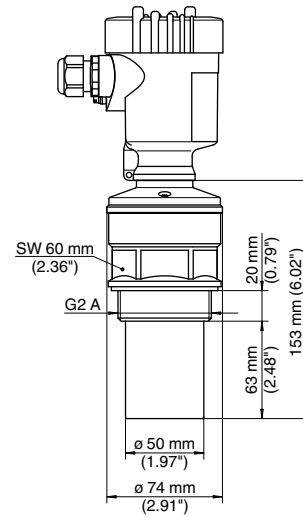

**VEGASON 63**

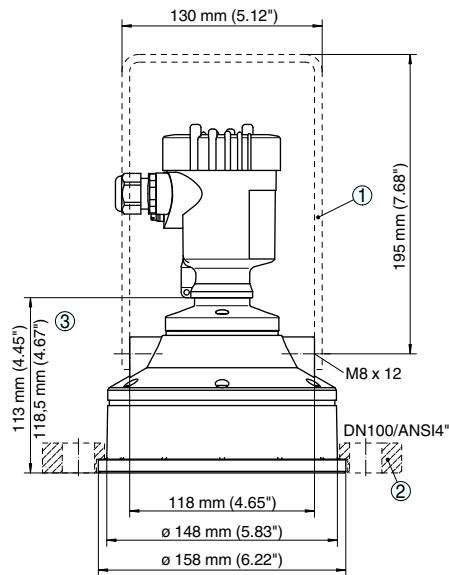

- 1 Mounting bracket
- 2 Compression flange DN 80

The listed drawings are only an excerpt of the available process fittings. You can find further drawings on [www.vega.com/downloads](http://www.vega.com/downloads) and "Drawings".



# VEGA

VEGA Grieshaber KG  
Am Hohenstein 113  
77761 Schiltach  
Germany  
Phone +49 7836 50-0  
Fax +49 7836 50-201  
E-Mail: [info.de@vega.com](mailto:info.de@vega.com)  
[www.vega.com](http://www.vega.com)

You can find at [www.vega.com](http://www.vega.com)

- operating instructions manuals
- specification sheet
- Software
- drawings
- certificates
- approvals

and much, much more



*Subject to change without prior notice*

29023-EN-130313