



Flow *Pulse*

INSTRUCTION MANUAL

FLOW PULSE (FIRST EDITION REV 2)

June 2013

Part Number M-560-0-001-2P

COPYRIGHT

© Pulsar Process Measurement Limited, 2012-13. All rights reserved. No part of this publication may be reproduced, transmitted, transcribed, stored in a retrieval system, or translated into any language in any form without the written permission of Pulsar Process Measurement Limited.

WARRANTY AND LIABILITY

Pulsar Process Measurement Limited guarantee for a period of 2 years from the date of delivery that it will either exchange or repair any part of this product returned to Pulsar Process Measurement Limited if it is found to be defective in material or workmanship, subject to the defect not being due to unfair wear and tear, misuse, modification or alteration, accident, misapplication or negligence.

DISCLAIMER

Pulsar Process Measurement Limited gives nor implies any process guarantee for the this product, and shall have no liability in respect of any loss, injury or damage whatsoever arising out of the application or use of any product or circuit described herein.

Every effort has been made to ensure accuracy of this documentation, but Pulsar Process Measurement Limited cannot be held liable for any errors.

Pulsar Process Measurement Limited operates a policy of constant development and improvement and reserves the right to amend technical details as necessary.

TECHNICAL ENQUIRIES

Please contact Pulsar Process Measurement Limited for technical support.

COMMENTS AND SUGGESTIONS

If you have any comments or suggestions about this product, then please contact:

Pulsar Process Measurement Limited

Cardinal Building
Enigma Commercial Centre
Sandy's Road
Malvern
Worcestershire
WR14 1JJ
United Kingdom

Tel: + 44 (0) 870 6039112

Fax: + 44 (0) 870 6039114

Web Site: <http://www.pulsar-pm.com>

e-mail: info@pulsar-pm.com (general information)

e-mail: support@pulsar-pm.com (product support)

Pulsar Process Measurement Inc.

PO Box 5177
Niceville
FL 32578-5177
USA

Tel: + 1 850 279 4882

Fax: + 1 850 279 4886

Web Site: <http://www.pulsar-pm.com>

e-mail: info.usa@pulsar-us.com (general information)

e-mail: support.usa@pulsar-pm.com (product support)

Contents

Chapter 1	Introduction.....	1
	About this Manual.....	1
	About the Flow <i>Pulse</i>	2
	Functional Description.....	3
	Product Specification.....	4
Chapter 2	Installation.....	7
	Power Supply Requirements.....	7
	Cable Screen and Earth Requirement.....	7
	Dimensions.....	8
	Terminal Connection Details.....	8
	Power.....	9
	Relay Output.....	9
	Current Output.....	9
	RS232 Serial Interface.....	9
	RS485 Serial Interface with Modbus.....	9
	Flow <i>Pulse</i> Installation Procedures.....	10
	Flow <i>Pulse</i> PC Installation.....	11
	Preparation for Operation.....	11
	Maintenance.....	12
Chapter 3	Setting-Up Flow <i>Pulse</i>	13
	Interface.....	13
	Using FlowPulsePC.....	13
	Pipe Internal Diameter.....	13
	Flow Tab.....	16
	Signal Strength.....	16
	Stability.....	16
	Flow Record Tab.....	17
	Trace Tab.....	18
	Parameters Tab.....	19
	Pipe Internal Diameter.....	20
	Calibration Factor.....	20
	Sensitivity.....	20
	Damping.....	21
	Volumetric Unit and Time Unit.....	22
	Access Level.....	22
	Step Response.....	23
	Step Response Threshold.....	23
	Flow Low and Flow High.....	23
	mA Output.....	24
	mA Output: mA Trim.....	25
	Relay/Alarm.....	26
	RS-485.....	27
	Manual Setting.....	28
	Setup Menu.....	29
	System Menu.....	29
	About Flow Pulse Menu.....	30
Chapter 4	RS 485 Parameter Guide.....	31
	Parameter System.....	31
	Parameter Access.....	31
	Output Parameters.....	32

Flow Rate (P20 and P21).....	32
Signal Strength (P22).....	32
Stability (P23).....	32
Configuration Parameters	33
RS485 Communication and Modbus.....	33
RS232 Communication	34
Processing Parameters	35
mA Output Parameters	36
Alarm/Relay Parameters.....	38
Flow Unit Parameters	40
Device Information Parameters.....	41
Device Control Parameters.....	42
Chapter 5 Optimisation and Diagnostic	45
Interpreting Diagnostic Trace	45
PC-over-RS485	46
Quick-Response Setup.....	47
Simulated Flow.....	48
Saving & Loading Device Parameters.....	48
Firmware Upgrade	49
High Noise Environment	50
Chapter 6 Common Questions and Answers.....	51
Will mechanical vibration affect flow measurement?.....	51
Is it possible to operate Flow Pulse in a high noise environment?.....	51
What is the effect of poor pipe condition?	51
What is the effect of pipe lining?.....	51
Does Flow Pulse measurement drift over time?.....	51
Can Flow Pulse be operated in a wet environment?.....	52
Chapter 7 Troubleshooting.....	53
LED Indication	53
Fault Registers and Log File	53
Flow measurement is significantly different from expectation	54
Flow reading under no-flow condition	55
Flow reading fluctuates or erratic	56
No flow indicated under flow-condition	56
Relay state not stable.....	56
Appendix: Parameter Record.....	57

Congratulations on your purchase of a Pulsar Flow *Pulse*. This quality system has been developed over many years and represents the latest in non-invasive ultrasonic flow monitoring.

It has been designed to give you years of trouble free performance, and a few minutes spent reading this operating manual will ensure that your installation is as simple as possible.

About this Manual

It is important that this manual is referred to for correct installation and operation.

About the Flow *Pulse*

The Flow *Pulse* is an ultrasonic non-invasive flow monitor designed for use on most industrial liquid flow applications. FlowPulse uses a novel spread spectrum analysis technique never before used in flow monitoring. It introduces a radical new Digital Signal Processing approach for exceptional repeatability.

Ultrasound is fired through the pipe wall at 90 degrees to the flow via a tangentially mounted high-output ceramic, then refracted at angles across the axis of the flow and subsequently reflected from bubbles, particles and vortices in all directions and at a wide range of frequencies. The wide, refracted, ultrasonic beam maximises the ultrasound energy captured from flowing particles. These multiple reflections are received back into the unit via a second crystal.

The mass of data generated is analysed using Flow *Pulse*'s Refracted Spread Spectrum Analysis (RSSA) digital signal processing platform to derive flow information. RSSA analyses and integrates the received signals over a wide frequency range, then uses them for real-time analysis and flow rate calculation.



Flow *Pulse* operates in a flow range from as little as 0.3m/s through to 4m/s, with a minimum particle size of 100 μ and concentration of 200ppm (the equivalent of hard water) or above.

Functional Description

The Flow *Pulse* injects an ultrasonic signal through the pipe, and analyses the returned signal in real-time to extract flow information. This provides robust and repeatable flow monitoring using a scalable 4 to 20 mA output and a volt-free relay switch. Interface with the PC over both the RS-485 and RS-232 serial port is fully supported by the Flow *Pulse* PC software, which can be used for setting up and operating the device.

In addition, there is a RS-485 with ModBus RTU communication protocol that interfaces Flow *Pulse* to Pulsar's optional wall mount unit. The optional wall mount has a LCD display and supports remote monitoring, logging, and programming of the Flow *Pulse*. There is also a mA output and a relay on the wall mount.

For the best results, Flow *Pulse* should be applied where:

- there is full pipe flow
- the pipe material is steel, cast iron, ductile iron, plastic or glass, but not rubber or flexible plastic pipes
- the pipe diameter is greater than 30 mm
- the pipe wall thickness is less than 20 mm
- the solids concentration in the fluid is greater than 200 ppm (e.g. hard tap water), and typical particle sizes are larger than 100 micron
- there is no significant build-up within the pipe

Product Specification

Physical

Outside dimensions	120 x 65 x 65 mm (4.75 x 2.6 x 2.6 inch)
Weight	Nominal 1.5 kg (3.3lbs)
Enclosure material/description	Type 316 stainless steel casting
Cable entry detail	1 cable entry M20 x 1.5mm gland
Maximum separation	500 m (1,640 ft)

Environmental

IP Rating (Wall)	IP68
Max. & min. temperature (electronics)	-20 °C to +70 °C (-4°F to 158°F)
Flammable atmosphere approval	Pending
CE approval	See EC Declaration of Conformity

Performance

Accuracy	±5% typical subject to installation and pipe conditions
Resolution	3mm/sec.)
Max. range (flow)	4.0m/sec.
Min. range	0.3m/sec.
Response time	fully adjustable (1 sec. minimum)

Signal Processing

Description	RSSA (Refractive Spread Spectrum Analysis)
-------------	--

Outputs

Analogue output	4-20 mA into a 1kΩ load with 20μA resolution and user programmable span
Digital output	Full Duplex RS232 to PC software, Half Duplex RS485 to PC software, Half Duplex RS485 with Modbus RTU
Volt free contacts, number and rating	1 form "C" (SPDT) rated at 1A at 24VDC

Programming

PC programming	via RS232 or RS485 using FlowPulse PC
Programmed data integrity	Via non-volatile RAM

Supply

Power supply	DC 18 - 28V
Power Consumption	2.5W @ 24V typical, 3W @24V maximum

Pulsar Process Measurement Limited operates a policy of constant development and improvement and reserve the right to amend technical details as necessary.

EC Declaration of Conformity

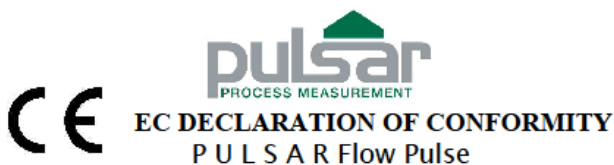

Relevant Directive(s) 2004/108/EC - EMC Directive and its amending Directives

Manufacturer's Name Pulsar Process Measurement Ltd.

Manufacturer's Address Cardinal Building,
Enigma Commercial centre, Sandy's Road, Malvern, WR14 1JJ, UK

Apparatus Pulsar Flow Pulse

Type of Equipment Ultrasonic Flow sensor

Equipment Class Industrial

Standards Applied

EN 61010-1:2001 Safety requirements for Electrical equipment for measurement, control, and laboratory use

EN 61326-1: 2006

Which calls up

CISPR 11

Conducted Emissions 150KHZ to 30MHZ

CISPR 11

Radiated Emissions 30MHZ to 1GHZ

BS EN 61000-4-2

Immunity to Electrostatic Discharge

BS EN 61000-4-3

Immunity to Radiated Fields

BS EN 61000-4-4

Immunity to Fast Transients

BS EN 61000-4-5

Immunity to Surges

BS EN 61000-4-6

Immunity to Conducted Interference

BS EN 61000-4-29

Immunity to Voltage Dips and Interruptions

I hereby declare that the equipment named above has been tested and found to comply with the relevant sections of the above referenced specifications. The unit complies with all essential requirements of the Directives.

Signed

Name: Dr Andrew Foo

Pulsar Process Measurement Ltd

Date

31st July 2012

Rev 1.0

This page left blank intentionally

Power Supply Requirements

The FlowPulse requires a DC 18-28V power supply. The typical power consumption is 2.5W and the maximum power consumption should not exceed 3W. The power supply should also be correctly fused at 250mA. Care should be exercised when connecting the power supply by ensuring the correct terminals and voltage rating are used to avoid damaging the device.

Cable Screen and Earth Requirement

A screened multi-core cable should be used (minimum conductor size of 0.5mm²). The cable screen should be connected to the enclosure at the cable entry point via the cable gland, see figure below. The screen of the cable should be earthed at the other end. The supplied cable gland is suitable for cables up to 10mm O.D.

If using RS485 then connect terminal 8 (RS485 SCR) to the Modbus return.

The power supply ground on Flow Pulse must not be earthed or connected to the cable screen.

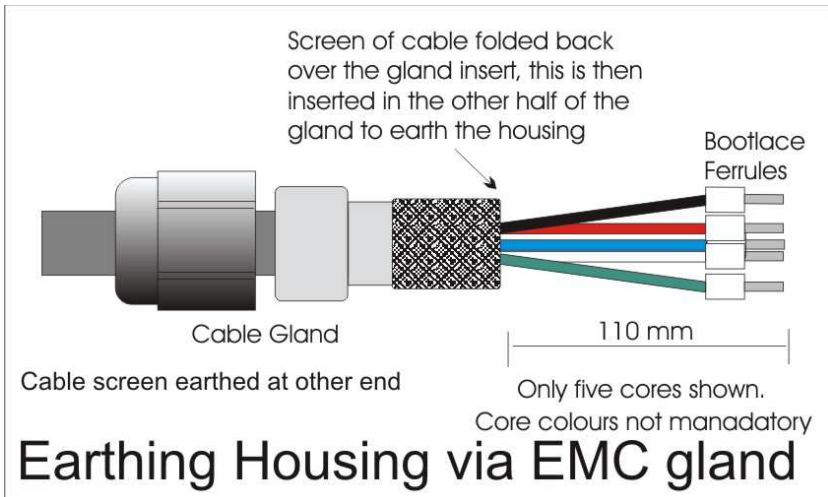

Dimensions

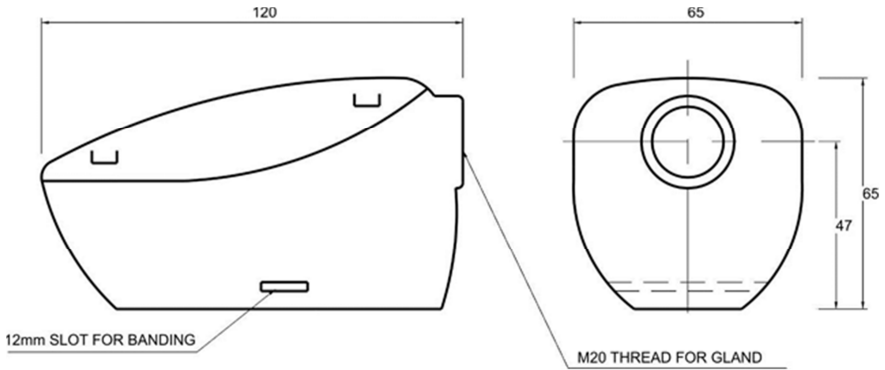

Cable Entry

It is recommended that you use the cable gland that comes with the Flow *Pulse* to ensure that the ingress rating is maintained.

Terminal Connection Details

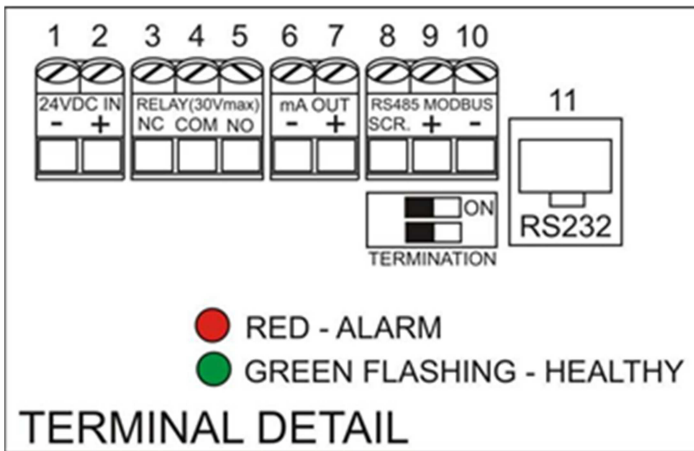

Terminal Connections

Power

Flow Pulse operates from DC power supply or batteries within the range of 18 to 28 VDC. When using a long cable (in excess of 100 m), please ensure that the minimum supply voltage is at least 22 VDC for the Relay to operate reliably.

Relay Output

The relay can be programmed for a variety of alarms. The relay contacts are rated at 1A at 24V DC. All connections should be such that the short circuit capacity of the circuits to which they are connected, is limited by fuses rated so that they do not exceed the relay rating.

The N.O. terminal is normally open while the N.C. terminal is a normally closed circuit to the common terminal.

Current Output

There is one mA output, of 4 - 20mA with a maximum load of 1k Ω . It has a 20 μ A resolution and a user programmable and adjustable span.

RS232 Serial Interface

The RS232 interface is available on the RJ-11 socket for setting up and operating the Flow Pulse using the FlowPulsePC program.

It is recommended that the serial cable does not exceed 10 metres in length.

RS485 Serial Interface with Modbus

It is recommended that a screened cable is used, and the cable screen is connected to the screen terminal of the RS485 terminals. If RS485 connection is not required, the cable screen should be connected to the metal enclosure of Flow Pulse at the cable entry point and earthed at the other end of the cable.

The RS485 terminals are galvanically isolated.

Please ensure that the termination switch is set to the “ON” position if termination is required.

The RS485 serial port can either be used with the Modbus RTU protocol or to interface with FlowPulsePC.

Flow Pulse Installation Procedures

All electronic products are susceptible to electrostatic shock, so follow proper grounding procedures during installation.

- Before installation, ensure that the necessary cabling has been fitted and that the device is not being powered.
- Flow Pulse must be mounted on the external, dry surface of the pipe. The device should not be submerged in liquid.
- Flow Pulse and the pipe surface around the installation location should not be exposed to external flowing liquid.
- Flow Pulse should be installed on a straight section of pipe at least 5 pipe diameters from any restrictions or sources of fluid turbulence (e.g. pumps, valves, tees, elbows) where possible.
- On horizontal pipes, it is preferable to mount Flow Pulse between 1 o'clock and 5 o'clock position on the pipe to avoid air pocket on top or sedimentation on the bottom, as illustrated in Figure 2:

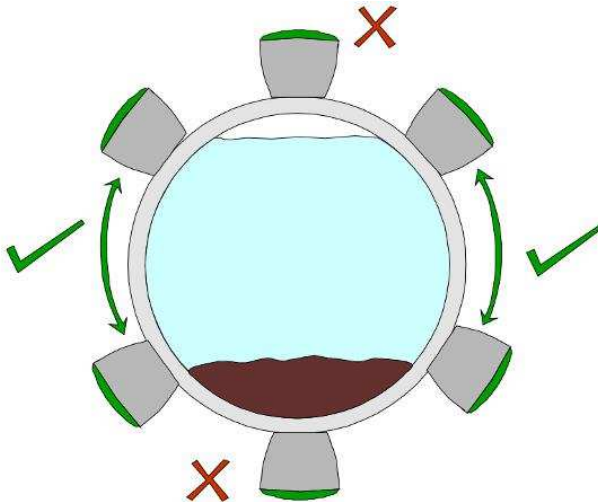

Figure 2: Recommended positioning on horizontal pipes

- Ensure that both the base of the Flow Pulse and the pipe surface are free from debris. Pipes with flaking paint should be cleaned down.
- Apply silicone grease or silicone pad to the base of Flow Pulse. Silicone pad is recommended where vibration and heat are frequently encountered.

- Flow Pulse should be strapped onto the pipe with the supplied metal banding. If further installation attempts are made, reapply silicone grease. In the case of silicone pad, ensure that the pad surface is clean from debris, the pad is in good condition, and there is no folding that might cause uneven contact with the pipe.
- Ensure that the Flow Pulse is aligned along the pipe axis, as illustrated in Figure 3:

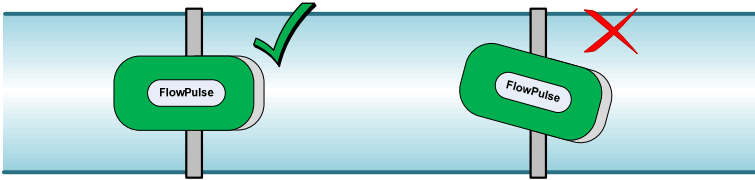

Figure 3: FlowPulse correctly aligned along the pipe axis.

- Tighten the banding while ensuring best contact and correct alignment between the Flow Pulse and the pipe.

Flow Pulse PC Installation

The Flow Pulse PC software is supported on Win XP, Win Vista and Win 7 (32 and 64 bit). The .Net Framework 4.0 is required to run the program. This is free for download online.

Run Setup.exe to install the FlowPulsePC software. A FlowPulsePC shortcut icon will be created on the Desktop. Double click on the shortcut icon to launch the program.

Preparation for Operation

Before applying power, check the following:

Flow Pulse is mounted correctly with optimum acoustic coupling between the base and the pipe surface.

The power supply is correctly connected at the terminal block.

There is no exposed or loose wiring around the connection terminals.

- Remove the lid, and apply power to the **Flow Pulse**.
- The RED led will flash for 6 seconds, then the GREEN led will begin to flash. The flashing of the GREEN led indicates that the device is operational.

- Connect the relevant serial cable and converter to the PC depending on whether RS232 or RS485 is being used.
- Launch the FlowPulsePC program. If using PC-over-RS485, change baud rate to 19200 using Setup->Serial Port, default is 57600 over RS232. Click the “Tick” icon to connect.
- When connection is established, the current parameters stored on the **Flow Pulse** will be extracted by FlowPulsePC. The “Device” bulb on the top right corner of the program will light up to indicate a successful connection.
- Choose the “Parameters” tab on FlowPulsePC, where the current device parameters are shown and can be modified. (please refer to the Chapter on Setting Up Flow Pulse before modification)
- On the top left corner of the “Parameters” tab, set the Pipe I.D. field to the pipe’s internal diameter in units of either millimetres (default) or inches.
- Click on the “SAVE” button.
- Return to the “Flow” tab to monitor flow.

Please refer to the Setting Up Flow Pulse chapter for more information.

Maintenance

There are no user serviceable parts inside Flow *Pulse*. If you experience any problems with the unit, then please contact Pulsar Process Measurement for advice.

To clean the equipment, wipe with a damp cloth. Do not use any solvents on the enclosure.

When relocating or reinstalling the Flow *Pulse*, please ensure that the pipe internal diameter value stored on the device is updated accordingly.

Interface

The default method for interfacing with Flow *Pulse* is by using the supplied Flow *Pulse* PC software and serial cable.

If the optional the Flow Monitor is installed, common setup parameters can be programmed directly from the Monitor. Please refer to the Flow Monitor user manual for more information.

Programmed parameters are stored in Flow *Pulse*'s non-volatile memory and are therefore retained after power-off.

Using FlowPulsePC

After launching the program and connecting to the Flow *Pulse*, the device parameters will be automatically extracted once a connection is established. Refer to the section on "Preparation for Operation" in Chapter 2 for more details on FlowPulsePC installation and how to connect to Flow *Pulse*.

Pipe Internal Diameter

The pipe internal diameter is the **only** parameter that **must** be entered to get the Flow *Pulse* working to measure the flow.

Choose "Parameters" tab, enter the pipe internal diameter in units of mm in the "Pipe I.D." field, then click the "SAVE" button.

Return to the "Flow" tab to monitor flow, the "Record" tab shows a time-plot of flow.

Figure 4 shows the main window of the FlowPulsePC software:

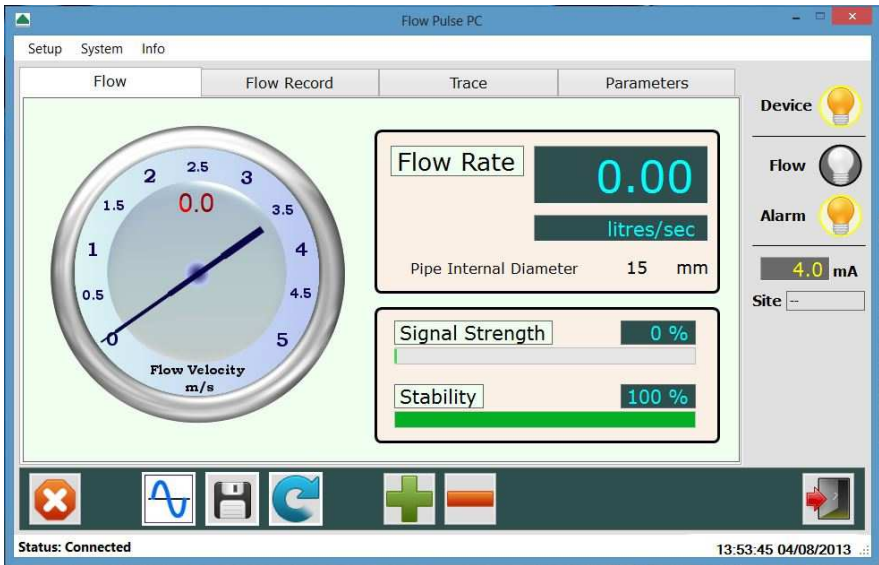









Figure 4: The flow information window of FlowPulsePC.

	<p>Connect: click to attempt connection to the Flow <i>Pulse</i> device.</p> <ul style="list-style-type: none"> • Set the baud rate to 57600 (Setup>Serial Port) with RS232 or to 19200 with RS485
	<p>Disconnect: appears after connection is established. Click to disconnect from the Flow <i>Pulse</i>.</p>
	<p>Diagnostic Trace: requests for diagnostic trace.</p> <ul style="list-style-type: none"> • When active, this icon border will light up yellow and ‘live’ traces can be observed on the “Trace” tab. • Click again to deactivate.

	<p>Save Data to File: click to record data from Flow <i>Pulse</i>. When activate, this icon will light up yellow. Click again to deactivate.</p> <ul style="list-style-type: none"> • In order to record diagnostic traces along with the flow data, please ensure that the trace icon is active and live traces are shown on the Trace tab. • The recording interval is set via the Setup->Recording Interval menu. The default is one record in every 2 seconds. • Files are automatically named with the “FlowPulse-” prefix followed by the current date+time stamp. An example is “FlowPulse-12-7-2012-08-00-00.txt” • If recording over a long duration, a new file will be automatically generated after 30 minutes. • The recorded data files are stored on the FlowPulsePC installation folder by default. • When recording is active, click again to stop recording.
	<p>Replay recorded data: click to replay recorded data. This can be performed without connection to a Flow <i>Pulse</i>.</p> <ul style="list-style-type: none"> • The program will disconnect from a Flow <i>Pulse</i> during replay. • A prompt will appear for choosing the data files to play. • Select the data files to replay, ensure that only FlowPulsePC recorded data files are selected. • To replay more than one file, select multiple files by holding down the CTRL key on the keyboard while clicking additional files. • Recorded traces are shown in the Trace tab and the recorded flow is shown in the Flow tab. • During replay, click again to stop.
	<p>Increase Replay Speed: during replay click to increase replay speed.</p>
	<p>Decrease Replay Speed: during replay click to decrease replay speed.</p>



Exit: click to exit program

Flow Tab

The default screen of FlowPulsePC is the Flow tab. The dial on the left displays the linear flow velocity, while the numerical display on the right shows the volumetric flow rate. The default volumetric unit is litres per second, and is configurable on the Parameters tab.

Signal Strength

The signal strength gives an indication of the strength of the flow signal detected. A signal strength level of higher than 60% is recommended for reliable operation. A higher Sensitivity setting may improve the Signal Strength (please refer to the Sensitivity section before changing).

Stability

The stability level is an indication of the consistency of flow reading, as derived from the combination of signal strength and statistical fluctuations of the flow reading. A high level of stability would point to a low-noise environment, clean and optimum acoustic pipe conditions, and a relatively laminar liquid flow within the pipe. However, the stability level does not necessarily indicate the accuracy of the flow reading as this is subject to calibration. A higher stability level indicates higher level of repeatability and better flow-tracking.

Flow Record Tab

The Flow Record provides a record of flow over time. Each point of flow on the graph represents a 1.2 second interval. However when the trace button has been pressed and a trace is being retrieved from the FlowPulse this slows down how frequently a point on the graph is plotted and the points then represent a 2 second interval.

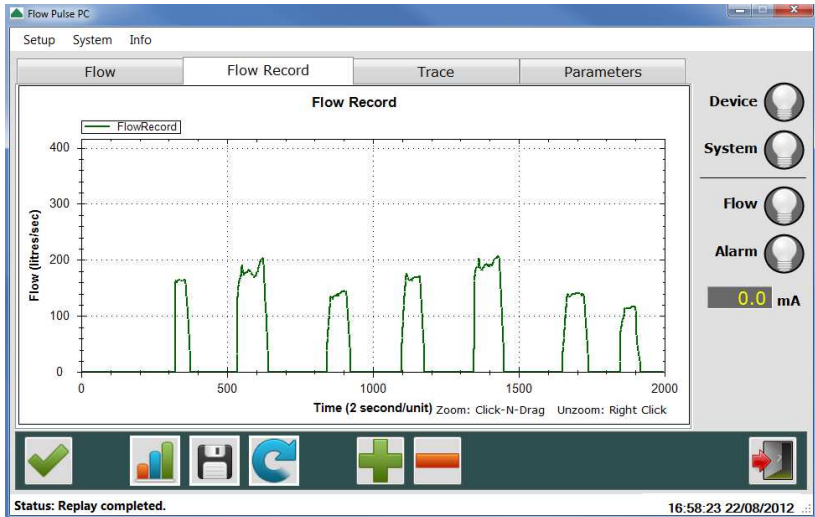

You can zoom in by clicking and holding the mouse then selecting the region to zoom in on. Zoom out by right clicking on the chart and selecting “Undo All Zoom”.

To clear the Flow Record chart, select Setup->Clear Flow Record Chart menu while the chart is inactive.

Note:

When the save data to file function is being used, flow information and traces will be written to file at the fixed interval selected via Setup->Recording Interval. (See Record to file function in “Using FlowPulsePC”).

Trace Tab

This calls and displays diagnostic traces when the Trace button is activated. Please refer to Diagnostic and Troubleshooting for more information on interpreting the traces.

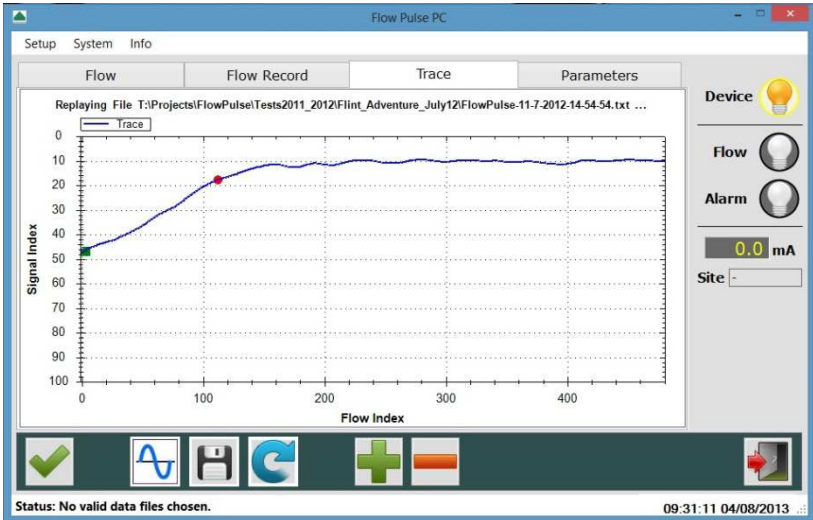

Parameters Tab

This enables the user to setup the Flow Pulse. It is important to note the following to ensure that Flow Pulse is correctly programmed:

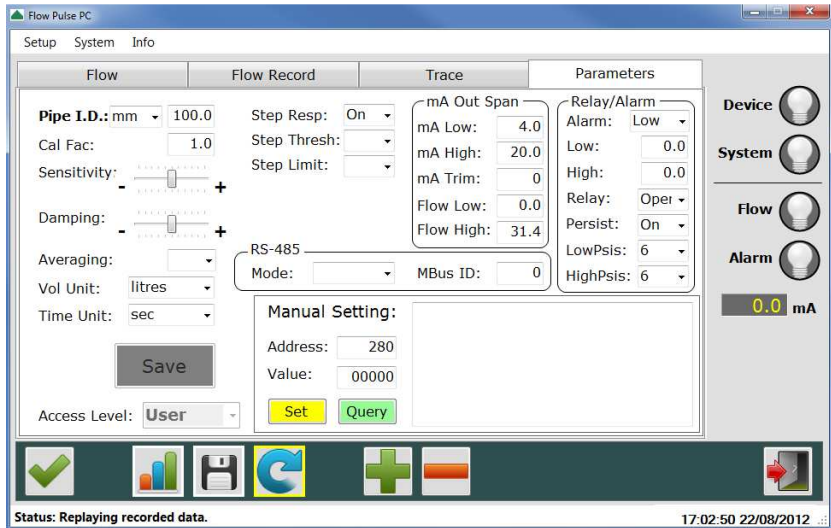

At every connection to Flow Pulse, FlowPulsePC will synchronise the values on the Parameter tab to that stored on Flow Pulse.

After changing any parameter, the “SAVE” button must be clicked to send and save the new values to the device.

The values need to be valid and within allowed range for a parameter change to be successful.

If the change is not successful, the values shown on the Parameter tab will reflect the current parameter value on Flow Pulse.

If Flow Pulse is being controlled simultaneously on both RS232 via FlowPulsePC and RS485 via Modbus interface, the values on the Parameter tab will not be instantly updated on FlowPulsePC if a parameter change is instructed via the RS485 Modbus.

Pipe Internal Diameter

The pipe internal diameter is the only parameter that must be entered after every Flow Pulse installation.

The default unit is millimetres (mm), with the option for unit of inches.

Calibration Factor

The calibration factor can be used to internally scale the flow reading by a multiplication factor.

As an example a factor of 0.5 will scale the reading to give only half of its original value, or a factor of 1.2 will scale the reading to give 120% of its original.

This is set to 1.0 by default, implying no scaling. Note that any change in the calibration factor is stored on Flow Pulse.

Sensitivity

The sensitivity of Flow Pulse can be increased for difficult pipes or liquids. When using Flow Pulse on high sensitivity setting, observations should be made to ensure that no-flow indication is consistent. Operating at higher sensitivity may increase the susceptibility of the device to external sources of noise.

A lower sensitivity may be desirable when operating in an environment that has the potential for electrical interference. At lower sensitivities, observations need to be made to ensure that there is sufficient signal strength for reliable detection of flow. This needs to allow for any long-term variation in pump or pipe conditions. In general, minimum signal strength of 60% is required.

It is recommended that the sensitivity be set as high as possible subject to the constraint of false flow indication under no-flow condition.

High Sensitivity	<ul style="list-style-type: none">• Good for low flow or poor pipe condition with weak signal strength.• If set very high, watch for false indication of flow when the pump is not running and there is no flow. This may not be critical in applications where the main alarm condition is for low or no flow while pumping is called for.
Low Sensitivity	<ul style="list-style-type: none">• Good for high flow or excellent pipe condition with strong signal strength.• If set very low, watch for false indication of no flow when the pump is running and there is flow. It is recommended that the sensitivity be set as high as possible subject to the constraint of false flow indication.

Damping

Fluctuations from non-laminar flow as well as from electrical noise will affect the stability of the flow readings. The damping parameter allows these fluctuations to be smoothed, at the expense of response time.

A higher damping will produce a more stable reading with less fluctuation, but the response time to a sudden change of flow is longer, and vice versa.

Note that a “Step Response” feature allows a large change of flow to bypass damping, potentially giving a faster response at the start and end of pumping cycles. Please refer to the Step Response section for more details.

By default, the damping is set to give a stable reading, and the response time is in the region of 30 seconds.

Volumetric Unit and Time Unit

The flow measurement on the Flow Pulse is performed in terms of volumetric flow rate.

The defaults are litres for the volumetric unit and seconds for the time unit, giving flow rate in units of litres per second.

This can be modified to give the desired units of flow rate. Please note that both volumetric and time units should be selected such that the numerical range falls within 0.01 to 60000 for the corresponding pipe internal diameter.

The table below lists the valid combination of volumetric and time units:

Valid Volume	Per Time
Litres	<ul style="list-style-type: none">• Second• Minute
Cubic Metres	<ul style="list-style-type: none">• Minute• Hour
Cubic Feet	<ul style="list-style-type: none">• Second• Minute
Imperial Gallons	<ul style="list-style-type: none">• Second• Minute
US Gallons	<ul style="list-style-type: none">• Second• Minute
Million US Gallons	<ul style="list-style-type: none">• Hour• Day

Access Level

The access level refers to the permission to perform actions or modify some parameters. There are two levels of access, the USER and SERVICE levels.

At power-up, the access level on Flow Pulse always defaults to USER.

Step Response

The step response allows Flow Pulse to temporarily bypass damping and track any sudden change in flow commonly encountered during the beginning and end of a pumping cycles.

This function is on by default.

Step Response Threshold

The step response threshold is the change in flow required for the normal damping to be bypassed. The range of the step response threshold is:

Min = 25, Max = 400 **Default = 60**

400 relates to the 'Flow High' value.

The higher the step response threshold, the larger the jump in flow needs to be before damping is skipped.

Flow Low and Flow High

The "Flow Low" and "Flow High" parameters represent the minimum and maximum flow rate setting, in units of volumetric flow rate.

By default, the flow rate limits, in units of litres per second, are set to correspond to the specification of flow velocity range of 0 to 4 m/s.

Note that the mA output is scaled to the flow rate limits that are set here. For example, if the range is set to Flow Low = 3 litres/sec and Flow High = 10 litres/sec, then the mA output will be 4 mA at 3 litres/sec and 20 mA at 10 litres/sec. Please refer to the "mA Output" section for more information.

mA Output

mA Low, mA High, Flow Low, Flow High

The mA output has a range of 4 to 20 mA by default. This is scaled to the flow range set by the Flow Low and Flow High parameters. The following figure illustrates this:

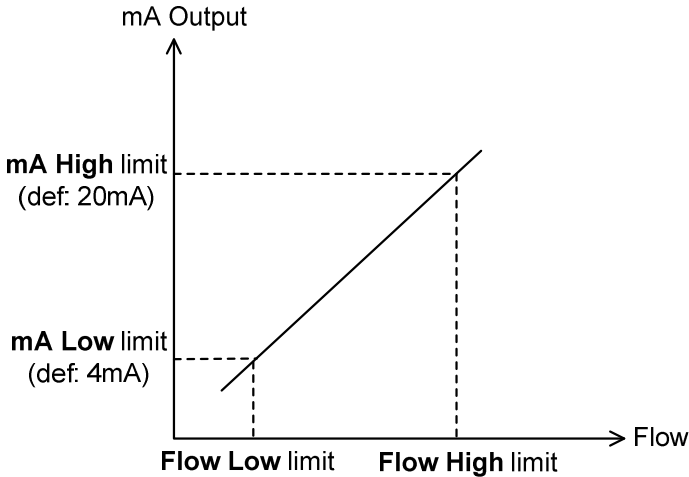

Figure 5: mA output scaling versus the low-high range of flow.

The mA High limit must be larger than the mA Low limit, and the Flow High limit must be larger than the Flow Low limit.

The Flow Low and Flow High limits are in units of volumetric flow rate as determined by the volumetric and time unit parameters (litres/sec by default). Therefore, the Pipe I.D. should be correctly set before setting the Flow Low and High limits.

As an example, in an application with low flow through a 100 mm Pipe I.D., the user can choose to scale the mA output from 4 to 20 to correspond to a flow range of 0 to 15 litres/sec instead of the full flow range of 0 to 31 litres/sec. This is achieved by first ensuring that the Pipe I.D. has been correctly set, and then setting the Flow High limit to 15 (the Flow Low limit is 0 by default).

The mA Low and mA High setting can also be used to make small adjustment to calibrate the device's mA output at Flow Low limit and Flow High limit. For example, if the mA output is 4.05 mA at Flow Low limit, the mA Low setting can be set from 4.0 to 3.95 for calibrating the actual mA output to 4.00 mA exactly.

mA Output: mA Trim

The mA trim allows calibration to the mA output by using a fixed mA offset. The offset is in units of microamps (uA).

For example, if the mA output is 4.1 mA at Flow Low limit, an offset of minus 100 uA can be entered. Entering and saving -100 (minus 100) to mA Trim would produce 4.0 mA at Flow Low limit.

The maximum offset allowed is ± 500 uA (± 0.5 mA). The mA trim should only be used to make small offset to the mA output. This offset is applied across the full mA range.

Relay/Alarm

The Relay/Alarm parameters allow the set points and switching mode to be configured. Figure 6 shows the alarm zones defined by the low and high set points, and the function of the different alarm modes.

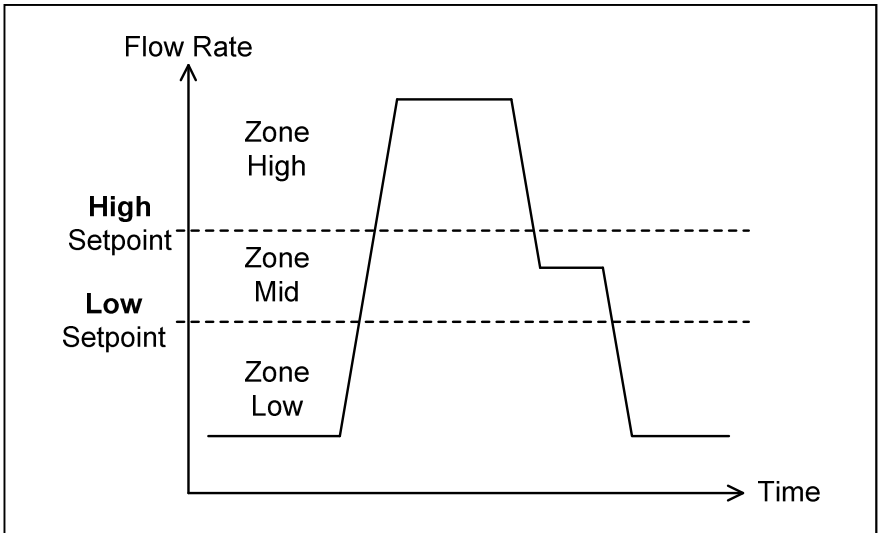

Alarm Mode	Zone Low	Zone Mid	Zone High
Low (Default)	Alarm ON	No Change	Alarm OFF
High	Alarm OFF	No Change	Alarm ON
Out of Range	Alarm ON	Alarm OFF	Alarm ON
Alarm OFF	De-energise	Alarm ON	Alarm OFF

Figure 6: The alarm modes and its effect in the relay/alarm zones as defined by the low and high set points.

The default alarm mode is low alarm.

The default relay mode is normally de-energised. The connection to the NC terminal is closed.

For low and high alarms, the Mid zone can be used as a buffer zone before switching occurs.

The Relay parameter (P204) is used to set whether you wish the relay to de-energise or energise in a state of alarm.

The Low and High Set-points are in units of volumetric flow rate as determined by the volumetric and time unit parameters (litres/sec by default). Therefore, the Pipe I.D. should be correctly set before setting the Low and High Set-points.

Persistence is the number of continuous flow reading that must exceed the relevant set points before the alarm/relay status is switched. The Low Persist (LowPsis) parameter is associated with the Low Set-point while the High Persist (HighPsis) parameter is associated with the High Set-point.

For example, at low alarm mode, the flow must exceed the High Set-point before the alarm is disarmed and the relay switched. If the High Persist value is set to 2, then there must be 2 consecutive flow readings that exceed this set point before a switch is triggered.

RS-485

The Flow Pulse can be interfaced using Modbus via the RS485 terminals. The default Modbus Slave ID is 126. The chapter on Parameter Guide provides more details on Modbus register addresses and valid values.

The RS-485 port can also be used to interface with the FlowPulsePC software, by selecting the PC-485 mode. Please ensure that you have a USB to RS-485 converter before setting Flow Pulse to this mode, as this is required for communicating with the device in the PC-485 mode. Refer to the PC-over-RS485 section in Chapter 5.

Manual Setting

There is an option for manually setting the parameters using the Manual Setting terminal on the Parameter tab, as illustrated in the following figure.

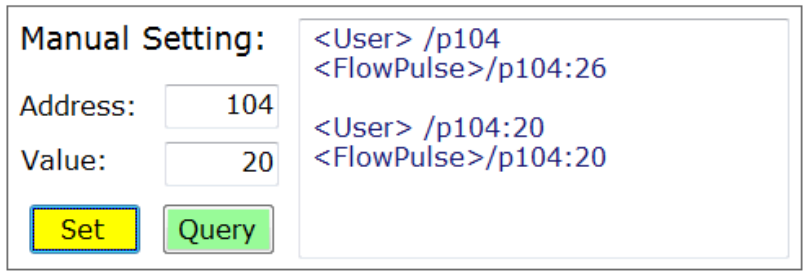

Manual Setting:

Address:

Value:

```
<User> /p104
<FlowPulse>/p104:26

<User> /p104:20
<FlowPulse>/p104:20
```

Figure 7: The manual setting window on the Parameter tab.

Every parameter on Flow Pulse is identified by a unique Address, and the content is the parameter Value.

All configurable parameters can be queried by entering the parameter address in the Address field and clicking on the Query button. The Flow Pulse will reply with the current value of the parameter.

For setting a parameter, both the Address and Value must be entered before clicking on the Set button. The appropriate access levels are required for setting parameters.

The list of parameter addresses and valid values are available in the chapter on Parameter Guide.

The Manual Setting terminal should not be used for the normal setting up of Flow Pulse. Refer to the “Parameter Guide” before setting parameters using address-value pair.

Setup Menu

This menu enables setting up of the RS232 port. The default setting when interfacing using FlowPulsePC is 57600 Baud 8bits-No Parity-1Stop bit. There is normally no need to change the default parameters. The COM port number is automatically detected.

The Recording Interval menu controls the time interval before a new flow record and trace is saved to file when the save-to-feature is in use.

The Clear Flow Record chart option allows the Flow Record chart to be cleared.

The “Work Folder” allows the setting of a default folder for data files to be saved.

System Menu

This menu provides the option to perform the following actions:

Save Device Parameters	Extract configuration parameters from the device and save onto PC as a parameter file. This is saved to FlowPulsePC’s installation folder and the filename is prefixed with “ParamFlowPulse-”.
Load Parameter to Device	Load the parameters from a parameter file onto Flow Pulse. This should only be used with a file that has a prefix of “ParamFlowPulse-”
Bootloader Control	Launch the BootloaderPC program for connecting to Flow Pulse’s Bootloader. This allows the firmware on Flow Pulse to be upgraded. Note that any customised parameters will be erased during a firmware upgrade, and therefore it is recommended that device parameters are saved onto PC before performing a firmware upgrade.
Reset Device To Bootloader	Reset Flow Pulse into Bootloader mode. The BootloaderPC program must be used to connect to Flow Pulse in this mode. Flow Pulse will resume normal operation if no connection is established within 30 seconds.
Parameter Factory Reset	This resets all parameters to factory default.

About Flow Pulse Menu

This menu provides information on the current version of FlowPulsePC program.

When connected to a Flow Pulse, information on the firmware and hardware versions of the device are also available.

Parameter System

Every parameter on the Flow Pulse is represented by a unique address and a value. The parameters consist of two main types: output parameters and configuration parameters.

Output parameters are read only and cannot be set by the user. Examples are current flow reading and current signal strength.

Configuration parameters can be queried and set. With each parameter, there is a factory default value, an associated access level which is required for setting, and a valid range of values for each parameter.

The parameters are always stored and entered as whole numbers, and the absolute range is from 0 to 65535, please refer to individual parameter for individual range.

The naming syntax for the parameters is with a prefix of 'p' before the address. For example, a parameter at address 102 is "P102". The value/content of the parameter is delimited by a colon ":", such that "P102:20" indicates that the parameter at address 102 has a value of 20.

The terms "parameter" and "register" are used interchangeably as the parameter number is the actual address of the storage register.

Parameter Access

The parameters on the Flow Pulse can be accessed using any of these methods:

- a) the parameters tab on FlowPulsePC (RS232 or RS485)
- b) the manual setting terminal on FlowPulsePC (RS232 or RS485)
- c) Modbus communication protocol (RS485)

It is recommended that only one method of access is used at any point in time.

Note: When using methods (b) or (c), the parameter guide in this chapter should be referred to as the value required may be different from the values normally entered on FlowPulsePC with method (a).

Output Parameters

Flow Rate (P20 and P21)

The current flow rate can be read from register 20 and 21, in the following format:

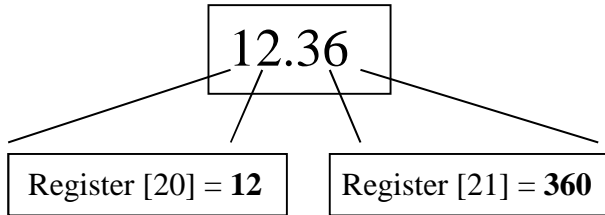

P20 contains the whole number part of the flow reading, while P21 contains the fractional part of the flow reading. The p21 is stored as whole number from 0-999 (allowing a fractional representation from 0.001 to 0.999).

Signal Strength (P22)

P22 gives the current signal strength in terms of percentage, from 1 to 100.

Stability (P23)

P23 gives the current stability in terms of percentage, from 1 to 100.

Configuration Parameters

RS485 Communication and Modbus

The default RS485 setting is 19200-8Bit-NoParity-1Stopbit.

P51 allows the Modbus protocol to be turned on and off, and P52 is the Modbus Slave ID of the Flow Pulse.

When using Modbus-RTU, note that the register addressing scheme uses Base-0 addressing protocol (i.e. there is no offset of 1)

Parameter	Addr	Options	Def.	Notes
Modbus Mode	51	0 = Not in use 1 = RTU 2 = N/A 3 = PC-485	1	ASCII mode not fully supported yet. The PC-485 mode enables FlowPulsePC interface using RS485. Modbus protocol turned off while using PC-485. Refer to PC over 485 section in Chapter 5 for more information.
Device Address	52	Unique Address, 1 - 127	126	Modbus device ID
Baud Rate	53	0 = 1200 1 = 2400 3 = 9600 4 = 19200 5 = 38400 6 = 57600 7 = 115200	4	Baud rate for RS 485.
Parity	54	0 = No parity 1 = Odd parity 2 = Even parity	0	Parity for RS 485
Stop Bit	55	1 – One stop bit 2 – Two stop bits	1	Stop bit for RS 485

RS232 Communication

The default RS232 setting is 57600-8Bit-Noparity-1Stopbit.

Parameter	Addr	Options	Def.	Notes
Baud Rate	61	0 = 1200 1 = 2400 3 = 9600 4 = 19200 5 = 38400 6 = 57600 7 = 115200	6	Baud rate for RS 232 FlowPulsePC/debug /reflash port.
Parity	62	0 = No parity 1 = Odd parity 2 = Even parity	0	Parity for RS 232
Stop Bit	63	1 – One stop bit 2 – Two stop bits	1	Stop bit for RS 232

Processing Parameters

The following are parameters that relate to the detection and processing of the flow signal.

Parameter	Addr	Options	Def.	Notes
Magnitude Threshold (Sensitivity)	102	1200 - 3000	1600	A higher number gives lower sensitivity.
Damping	104	10 - 40	24	A higher number gives more damping.
Average Count	105	1 - 20	6	This is the number of averaging to perform on the reading – this is independent of the damping process. Reducing this will increase flow sampling rate at the expense of measurement stability.
Calibration Factor	108	1 - 500	100	The calibration factor for flow reading in percentage terms, default is 100%. As example, 50% would half and 200% would double.
Pipe Internal Diameter	110	10 - 3000	15	Expected Pipe Internal Diameter in units of millimetres.
Step Response Mode	113	0 = Off 1 = On	1	When StepResp is off, no damping by pass will be performed.
Step Response Threshold	115	22 - 426	60	The threshold that the step change size needs to exceed before damping by pass is invoked. May use diagnostic trace to adjust this.

Parameter	Addr	Options	Def.	Notes
Step Change Limit	121	22 - 426	119	StepChangeLimit is the limit on any sudden change in flow reading. May use diagnostic trace to adjust this.

mA Output Parameters

The following are parameters that relate to the mA output and scaling to flow measurement. Please refer to the diagrams in Chapter 3 –mA Output sections before setting the parameters manually or over Modbus.

Parameter	Addr	Options	Def.	Notes
mA Low	162	3000 - 9000	4000	In units of uA (1000=>1mA). This can be used to adjust the lower limit of the mA output. Small adjustment can also be made to calibrate the mA output .
mA High	163	10000 to 20000	20000	In units of uA (1000=>1mA). This can be used to adjust the higher limit of the mA output. Small adjustment can also be made to calibrate the mA output.
mA Trim	164	0 - 1000	500	In units of uA, applies an offset across the full range of mA output. This is centred upon 500, such that the default value of 500 = 0 offset. 400 would give -100 uA offset, while 650 would give +150 uA offset. This differs from the method of

Parameter	Addr	Options	Def.	Notes
				directly entering -100 or +150 on the FlowPulsePC parameter tab.
Flow Low (Integer part)	176	0 - 65535		P176 contains the whole number part of Flow Low limit, while P177 contains the fractional part of Flow Low limit. The P177 is stored as whole number from 0-999 (allowing a fractional representation from 0.001 to 0.999) Note: The flow value is in units of the current volumetric flow rate
Flow Low (Fractional part)	177	0 - 1000		
Flow High (Integer part)	178	0 - 65535		P178 contains the whole number part of Flow High limit, while P179 contains the fractional part of Flow High limit. The p179 is stored as whole number from 0-999 (allowing a fractional representation from 0.001 to 0.999) Note: The flow value is in units of the current volumetric flow rate
Flow High (Fractional part)	179	0 - 1000		

Alarm/Relay Parameters

Please refer to the diagrams in Chapter 3 – Relay/Alarm section before setting the Alarm/Relay parameters manually or over Modbus.

Parameter	Addr	Options	Def.	Notes
Alarm Mode	201	0 = Low alarm 1 = High alarm 2 = Out of range alarm 3 = In range alarm	0	Refer to Relay/Alarm section in Chapter 3.
Relay Mode	204	0 = Non-Energised during Alarm (power-failure => alarm) 1 = Energised during Alarm	0	
Persist Mode	205	0 – Off 1 – On	1	Switch both low and high persist on or off.
Low Set Point Persist	206	0 - 100	2	The number of times that a low set point is exceeded consecutively before triggering relay.
High Set Point Persist	207	0 - 100	2	The number of times that a high set point is exceeded consecutively before triggering relay.
Low Set Point (Integer Part)	208	0 - 65535		P208 contains the whole number part of Flow Low limit, while P209 contains the fractional part of Flow

Parameter	Addr	Options	Def.	Notes
Low Set Point (Fractional part)	209	0 - 1000		Low limit. P208 is stored as a whole number from 0-999 (allowing a fractional representation from 0.001 to 0.999). Note: The flow value is in units of the current volumetric flow rate.
High Set Point (Integer part)	210			P178 contains the whole number part of Flow High limit, while P179 contains the fractional part of Flow High limit. The p179 is stored as whole number from 0-999 (allowing a fractional representation from 0.001 to 0.999). Note: The flow value is in units of the current volumetric flow rate.
High Set Point (Fractional part)	211			

Flow Unit Parameters

The table below lists the valid combination of volumetric and time units:

Valid Volume	Per Time
Litres	<ul style="list-style-type: none"> • Second • Minute
Cubic Metres	<ul style="list-style-type: none"> • Minute • Hour
Cubic Feet	<ul style="list-style-type: none"> • Second • Minute
Imperial Gallons	<ul style="list-style-type: none"> • Second • Minute
US Gallons	<ul style="list-style-type: none"> • Second • Minute
Million US Gallons	<ul style="list-style-type: none"> • Hour • Day

Parameter	Addr	Options	Def.	Notes
Volumetric Unit	192	1 – litre 2 – cubic meter 3 – cubic feet 4 – UK Gal 5 – US Gal 6 – Mil US Gal	1	NOTE: Refer to the table on valid combinations of volumetric and time units. Setting invalid combinations will result in significant measurement errors.
Time Unit	193	1 – sec 2 – minute 3 – hour 4 – day	1	

Device Information Parameters

These parameters are read-only, and are usually only updated by the device.

Parameter	Addr	Def	Notes
Serial Number	240 & 241		Registers 240 and 241 form a 32-bit number. Register 240 => Most significant 16-bit Register 241 => Least significant 16-bit
Firmware ID	261		A number associated with the version of firmware.
Hardware ID	262		A number associated with the version of hardware.

Device Control Parameters

These parameters are for controlling the device or to perform system action.

Parameter	Addr	Def	Notes
Access Parameter	280	0	Write the necessary access code to this register in order to gain associated access level. No access code is required for user-level access. Read from this register to get the current access level: 0: User-level 1: Service-level
Simulated Flow	288	0	Switch simulated flow on and off. 0: Off 1: On This is switched Off with every power-up. As simulated flow overrides real flow, ensure that this is switched Off when not required.
Simulated Flow Value	289	0	Simulated flow value in millimetres/sec. When on, simulated flow value will override any real flow detected. Simulated flow is affected by calibration factor, controls mA output and triggers relay in the same way as real flow.
Factory Reset	297	0	Writing integer 7 to this register will reset all parameters to factory default.

Parameter	Addr	Def	Notes
Reset to Bootloader	299	0	<p>Writing integer 9 to this register will reset the device into Bootloader mode.</p> <p>Device will remain in Bootloader mode for around 35 seconds. If no Bootloader software is connected to the device after 35 seconds, device will resume normal operation if a valid firmware is already present.</p>

This page left blank intentionally

Interpreting Diagnostic Trace

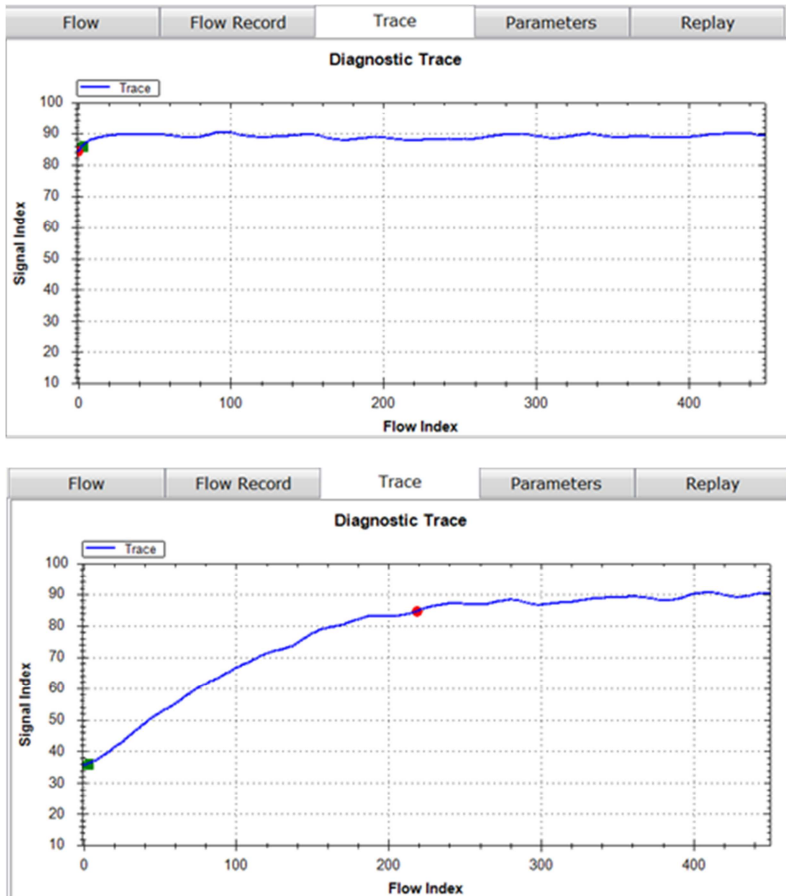

Figure 8: Example of traces for no-flow (top) and 2.0 m/s flow (bottom).

The vertical axis is related to the signal strength, while the horizontal axis is related to detected flow.

The top chart in Figure 8 shows the trace under no-flow condition. When there is no flow, the trace should be relatively flat and rest on signal index=90. If the line is not relatively flat, does not rest around signal index

of 90 or there is any peak that is more than 10 signal index in size, then noise is affecting the device.

When signal is received, the Green square indicator will move down from 90 on the vertical axis. The further the Green indicator moves from 90, the larger the strength of the received signal. During flow condition, the Green indicator will normally be within the range of 30 to 70.

When flow is detected, the Red circle indicator will move horizontally to indicate flow detection. The Red indicator should always be within 80 to 90 on the vertical axis, under both flow and no-flow conditions. On the horizontal axis, the Red indicator should stay at 0 under no-flow, and move along the horizontal axis when flow is detected.

Under flow condition, the line should still approach and flat-line at signal index 90.

If the trace remains flat or the indicators struggle to remain stable during flow, then increase the Sensitivity setting.

Refer to the High Noise Environment section if unusual observations are seen on the diagnostic trace.

PC-over-RS485

In addition to the RS232 port, Flow Pulse can also be interfaced to the PC via the RS-485 connection. A standard USB to RS485 converter is required. While using PC over RS-485, the Modbus RTU protocol will not be available. Follow these steps to use PC over RS-485:

- 1) If PC-over-485 is already enabled, then skip to Step 3 otherwise connect over RS232 and use FlowPulsePC to set the RS485 mode to PC-485. Alternatively, if Modbus RTU is running on RS485, set register 51 to value 3.
- 2) Once the mode is saved or the register set, the change will take effect immediately. Therefore current connection of FlowPulsePC over RS232 or Modbus will be terminated.
- 3) Remove the USB to RS232 converter, and connect the USB to RS485 converter to Flow Pulse.

To restore, set RS485 mode to Off or Modbus RTU (register 51 to 0 or 1). Set the baud rate on FlowPulsePC back to 57600 when using the RS232 port.

Quick-Response Setup

In applications where a quick response is required, the Flow Pulse can be set to give a minimum response time of approximately 1 second. Please follow these steps to setup Quick Response:

- 1) Establish connection using FlowPulsePC
- 2) Slide Sensitivity to the lowest setting.
- 3) Slide Damping to the lowest setting.
- 4) Set Avging to 2.
- 5) Set Step Thresh to 40.
- 6) Set Step Limit to 300.
- 7) Set Persist to Off.
- 8) Click SAVE and wait for 10 seconds to complete.

While testing the response time, please ensure that diagnostic traces are not being called by FlowPulsePC.

To restore factory default, select System->Parameter Factory Reset.

Simulated Flow

Simulated flow can be used to test the device output and response. Using the Manual Setting:

- 1) Set register 288 to value 1 to turn on simulated flow.
- 2) Set register 289 to the flow value in units of millimetres/second flow speed.
- 3) Turn off simulated flow by setting register 288 to 0.

Simulated flow overrides actual flow and must therefore be turned off when not required.

Saving & Loading Device Parameters

For a device which parameters are heavily customised, the user may wish to replicate such customisation on a second device. Saving and loading parameters can be used to avoid having to set-up the parameters individually again:

- 1) Connect FlowPulsePC to the first device, then select System->Save Device Parameters.
- 2) A confirmation message will appear and the parameters saved to a file within the default folder (use Info->Data Folder Path to see the folder location). The filename is prefixed by "ParamFlowPulse-" followed by the date and time.
- 3) Connect FlowPulsePC to the second device on which to load the parameters. Select System->Load Parameters to Device, then choose the parameter file to load.
- 4) Reconnect FlowPulsePC to see new parameter values.

Firmware Upgrade

Ensure that Device Parameter Cloning is performed to ensure that any customised parameters are saved before proceeding with a firmware upgrade.

Firmware upgrade is performed in the Bootloader mode. Note that all flow measurement and output operation will be halted when the Flow Pulse is in the Bootloader. Please follow these steps:

- 1) Please ensure that the device is connected to the PC via the RS232 port or the RS485 port. You need the firmware file, and the COM port number on the PC.
- 2) Put the device into Bootloader mode by connecting FlowPulsePC and select System->Switch Device into Bootloader.
- 3) Select System->Bootloader Control on FlowPulsePC, this will launch the Bootloader interface

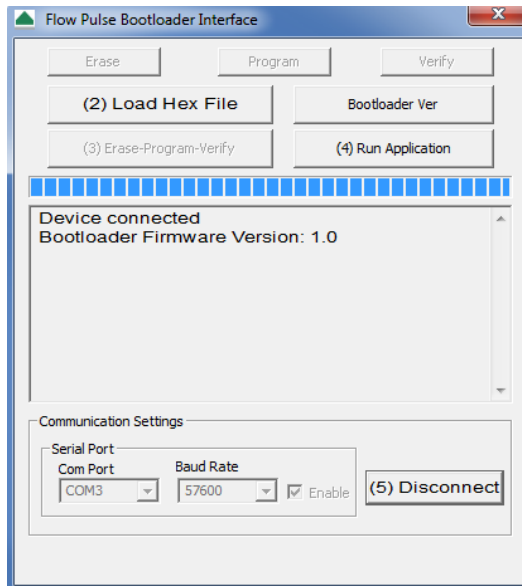

- 4) On the Bootloader Interface, choose the COM port number of the PC that is connected to the device. For Baud Rate, choose 57600 if using RS232, or 19200 if using RS485. Click Connect.
- 5) Click Load Hex file, and choose the firmware file.
- 6) Click Erase-Program-Verify, and then wait for the process to complete.
- 7) When “Verification successful” message is displayed, click Run Application then click Disconnect.
- 8) Close the Bootloader Interface program, and reconnect to the device using FlowPulsePC.

When the device is in Bootloader mode, the Red led flashes continuously and the Green led is off.

In step (4), if the Bootloader Interface software does not connect to the device within 40 seconds, the device will resume normal operation with its current firmware. Repeat step (2) to put the device into Bootloader mode again.

High Noise Environment

Flow Pulse may be affected by both ultrasonic and electrical noise. Exercise the following precautions during installation:

- 1) Avoid using other clamp-on ultrasonic device less than 1 metre from Flow Pulse.
- 2) Ensure that screened cables are used and that the Flow Pulse enclosure is properly Earthed – do not connect the cable screen to the Ground (-) terminal of the power supply or the mA output. If RS485 is not used, the cable screen should be connected to the enclosure using the cable entry gland. If RS485 is used, connect cable screen to the RS485 screen terminal, then earth the Flow Pulse enclosure separately if possible.
- 3) Relocate the device away from pumps, valves, tees or elbows where possible.

Will mechanical vibration affect flow measurement?

Typical mechanical vibration sources such as pumps are much lower in frequency compared to the ultrasonic signal of the Flow Pulse. However, in situations where the signal strength is weak (less than 70% with maximum sensitivity) the accuracy may be affected or there could be readings under no-flow conditions. Very strong continuous mechanical vibration may affect the mechanical coupling of the device. Install away from vibrational sources if possible, or use damping material between clamping band and pipe to reduce vibration.

Is it possible to operate Flow Pulse in a high noise environment?

Yes, refer to High Noise Environment section in this chapter.

What is the effect of poor pipe condition?

One of Flow Pulse's unique strength is its ability to detect flow with very weak ultrasonic signals. However, severe pipe corrosion, both externally and internally, can affect the accuracy of measurement. Flaky pipe surfaces should be cleaned and sand-down. Severe build up or deposit on the pipe internal can also significantly attenuate ultrasonic signal.

What is the effect of pipe lining?

Any form of lining with air gap between the liner and the pipe wall will stop ultrasonic signal. Better results can be expected with bonded liners such as cement, epoxy and tar. However, an on-site test is highly recommended for lined-pipe applications.

Does Flow Pulse measurement drift over time?

Flow Pulse is calibrated using an in-house test-rig with a Magnetic Flowmeter installed. Any electronically induced drift is several magnitudes smaller than the specified variation of Flow Pulse due to the precise crystal-controlled timing circuitry.

Can Flow Pulse be operated in a wet environment?

The Flow Pulse enclosure is rated at IP68 to give maximum electrical safety in the event of accidental or temporary contact with liquid. Operation in an environment that frequently exposes the device to liquid is not recommended. External liquid moving in direct contact with the device or the pipe surface where it is installed may be interpreted as flow and produce flow reading in no-flow conditions. Consider applying an air filled or porous cladding around the device and pipe vicinity to prevent detection of external liquid flow.

LED Indication

GREEN	RED	STATUS
Flashing	On	Normal operation, with alarm condition
Flashing	Off	Normal operation, no alarm condition
Flashing	Off with Alarm Condition	A recoverable fault has occurred, check Fault Codes (query registers 270 – 279) If repetitive servicing maybe required
Off	Flashing	In Bootloader mode/Waiting for connection from Bootloader PC software.
Off	Off	Device not powered, or if powered, a critical fault has developed.

Fault Registers and Log File

The registers 270-279 can be queried (via FlowPulsePC or Modbus) to check for fault codes:

- 1: Retrieved parameter exceeded valid range.
- 2: Parameter value entered by user exceeded valid range.
- 3: Number of self-reset events (register 266) exceeded the maximum allowed.
- 4: Fail to retrieve stored parameters.

While using FlowPulsePC, all parameter changes are time-stamped and logged to a file within the Debug folder.

Flow measurement is significantly different from expectation

POSSIBLE CAUSES	ACTION
Calibration Error	Verify Pipe Internal Diameter setting
Actual flow rate is indeed different from what is expected	Check pump and valves, verify flow using other methods.
Improper device installation	Check clamping is not loose and coupling compound is applied. If a coupling pad is used, ensure that it is not creased, torn or folded.
Inadequate signal penetration	Relocate closer to elbows or flow disturbance as internal build-up and deposit may be less severe. Do not install directly on Tees or elbows.
Pipe is not full	Reinstall on the lower quadrant of the pipe.
Noise and/or interference	<p>If possible, relocate away from pumps and valves (about 10 diameters), and elbows and tees (about 5 diameters). Ensure a screened cable is used, and the screen is not connected to the ground of the power supply or mA output. The cable screen should be connected to the enclosure using the cable entry gland and earthed on the other end. If RS485 is used, the cable screen should be connected to the RS485 screen terminal and the Flow Pulse enclosure separately earthed if possible.</p> <p>If variable speed drives (VSD) are present ensure that VSD manufacturers wiring and grounding instruction is followed.</p> <p>Reinstall device and cabling away from VSD and isolate power supply.</p> <p>Refer to the High Noise Environment section in this chapter.</p>

Flow reading under no-flow condition

POSSIBLE CAUSES	ACTION
Strong vibration on pipe	Reduce the “Sensitivity” setting. Reinstall away from vibration source.
Local electrical noise	Ensure screen cable is used, and the screen is not connected to the ground of the power supply or mA output. The cable screen should be connected to the enclosure using the cable entry gland and Earthed on the other end. If RS485 is used, the cable screen should be connected to the RS485 screen terminal and the Flow Pulse enclosure separately Earthed if possible.
Variable Speed Drive (VSD) interference	Ensure that VSD manufacturers wiring and grounding instruction is followed. Reinstall device and cabling away from VSD and isolate power supply.
Contact with external flowing liquid	Clad the device and pipe vicinity with porous or air filled material (i.e. similar to bubble wrap) to prevent ultrasonic signal from reaching external flowing liquid.

Flow reading fluctuates or erratic

POSSIBLE CAUSES	ACTION
Device installed too close to valve, pump, tees or elbows. Non-return valves can produce strong knocking.	Reinstall further away if possible. Increase the “Damping” setting on the device. Turn “Step Response” off if necessary. Use a smaller “Step Limit” if fluctuation persists. The response time will increase with such settings.

No flow indicated under flow-condition

POSSIBLE CAUSES	ACTION
Coupling compound washed out or worn.	Check and reapply coupling compound if necessary.
Insufficient suspended particles or gases, poor pipe condition, severe (more than 50%) internal build-up, or flow too low.	Increase “Sensitivity” setting. Relocate onto the top position of the pipe. Relocate to more turbulent pipe section.

Relay state not stable

POSSIBLE CAUSES	ACTION
Frequent crossing of the low and high set points.	Increase “Damping”, and turn “Step Response” off if necessary. Increase buffer between low and high set points. Turn on “Persistence” and increase low and high persistence numbers

Appendix: Parameter Record

Parameter Details	Entered Values					
Description	Default	1	2	3	4	5
Pipe Internal Diameter	100					
Calibration Factor`	100					
Volumetric Units	1 (litre)					
Time Unit	1 (second)					
mA Low	4mA					
mA High	20mA					
mA Trim	-					
Flow Low	-					
Flow High	-					
Alarm Mode	0 (Low)					
Low Set	0.0					
High Set	0.0					
Relay Mode	0					
Low Persist	-					
High Persist	-					
RS 485 Mode	3					
Modbus ID	1					
Firmware	Read Only					